

ASTROINERTIAL NAVIGATION SYSTEM (ANS) TAPE 12

The ANS is an inertial navigation system employing a star tracker to eliminate gyro drift and to limit position error. The system provides a steering signal to the autopilot for guiding the aircraft automatically along a predetermined flight path. It provides heading, attitude, and position information to cockpit displays. The ANS can control the CAPRE side-looking radar and technical objective cameras for imaging operations. The ANS supplies navigational data to the electromagnetic - reconnaissance sensor and mission data to the mission recorder system. See Figure 4-1 for an ANS functional diagram.

SYSTEM INTERFACES

The ANS provides signals for aircraft systems as seen in Figure 4-1. The following equipment is either controlled by or receives inputs from the ANS:

1. DAFICS (for Autopilot and SAS analytical redundancy (ANR)).
2. Attitude Indicators (Pilot and RSO).
3. Flight Director Computer.
4. Horizontal Situation Indicator (Pilot).
5. Bearing, Distance, Heading Indicator (RSO).
6. Mission Recorder System.
7. EIP.
8. Technical Objective Cameras (in AUTO).
9. Optical Bar Camera
10. V/H System.
11. Viewsight.
12. Radar, including the RCD (controlled when in AUTO).

13. RSO Annunciator Panel.
14. Pilot Annunciator Panel.
15. Sensor time counter driver.
16. Peripheral Vision Display (PVD).

MODES OF OPERATION

The navigation system has four navigation modes: (1) astro inertial, (2) inertial only, (3) airstart (airspeed-damped astro inertial), and (4) dead reckoning. Figure 4-2 summarizes the navigational errors expected in each mode. The mode to be employed depends on the time for activation and alignment, and whether the aircraft is on the ground or airborne when the ANS is turned on. Astro inertial is the preferred mode.

ASTRO INERTIAL Mode

In this mode, navigation errors will be relatively small, depending on the alignment method, and do not increase with mission duration. As soon as the system begins navigating the star tracker automatically begins to search for stars. Stars are normally tracked at night and during the day provided good sky conditions exist. A 61 star catalog is stored in the ANS computer. Either normal or special coverage for the SR-71B trainer can be provided. The sun, moon and planets, are not used by the star-tracker. At least two different stars must be tracked for optimum performance. The star tracker measures the difference between the inertial platform orientation and celestial computed position. Data derived from stars is used to correct true heading, computed position, computed velocity, platform tilt, and gyro drift rates. Measured gyro drift rates are stored in the computer memory and are used to improve any subsequent inertial only navigation. This sequence eliminates the unbounded position error growth characteristic of pure inertial systems.

In a normal mission, either a rapid or gyro compassing alignment is performed prior to navigation. These alignments require 18 minutes and 36 minutes respectively, exclusive

SECTION IV
 NAVIGATION AND SENSOR CONTROL SYSTEM

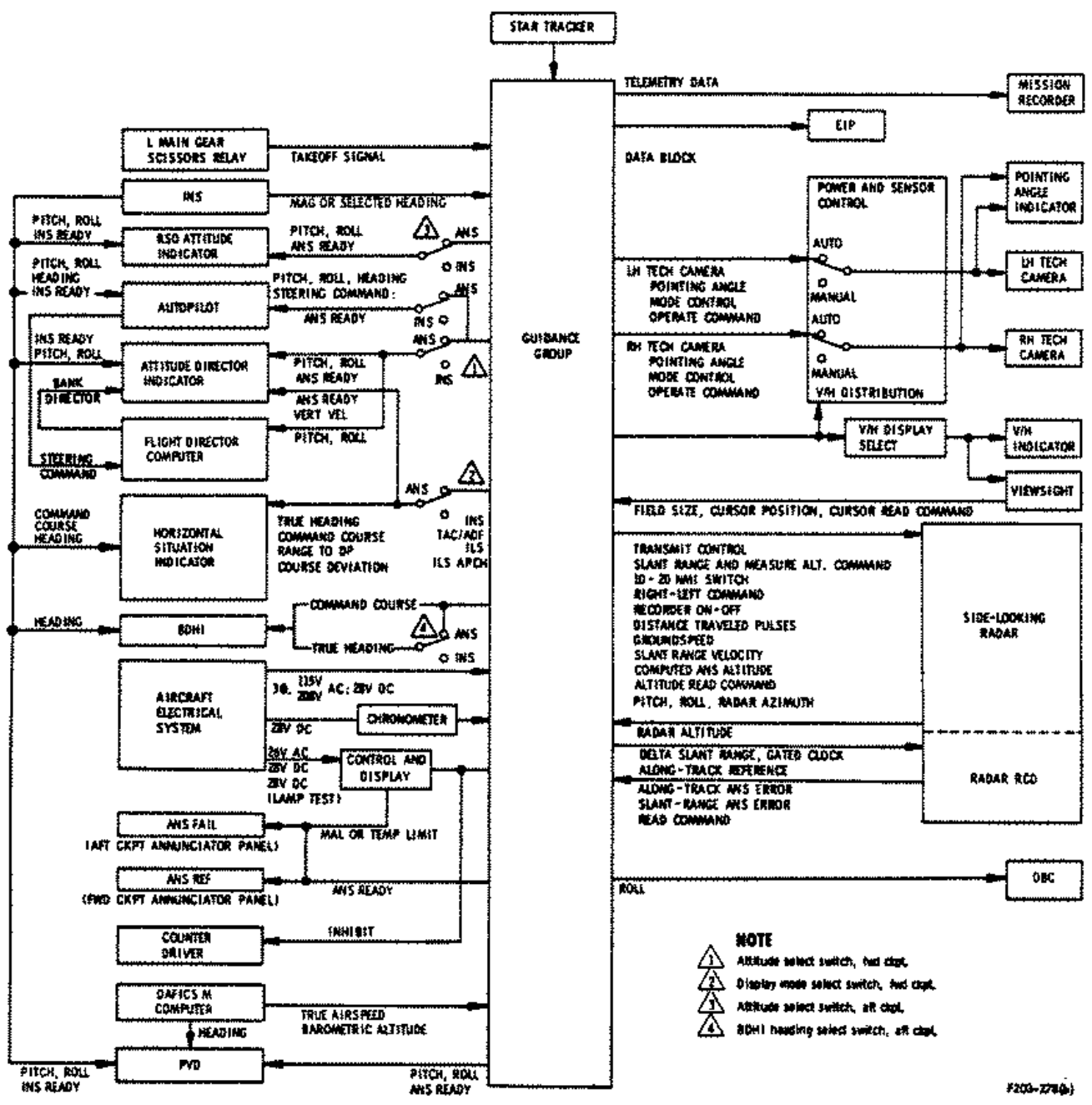

Figure 4-1

of warmup time. A ground hot start can be performed on a system previously aligned and shut down or on a system which has been shut down after operation in the astro inertial or inertial-only mode, provided the aircraft has not been moved. A runway heading alignment is recommended after a rapid alignment or a ground hot start. A heading update may or may not be required.

INERTIAL-ONLY Mode

INERTIAL-ONLY mode, in which only the inertial portion of the astroinertial system is employed, is recommended when the star-tracking capability of the navigation system is impaired. In this mode, navigation errors are unbounded.

AIRSTART Mode

The airspeed-damped, astro inertial (airstart) mode, which uses both the inertial platform and star tracker, is intended for: (1) scramble-initiated flights when the system is not prepared for a ground hot start, and (2) restart in flight. In this mode, errors can be large at first but should damp down with time to the values in Figure 4-2. Dead reckoning data are used for present position until three different stars have been acquired (steady illumination of the star ON light). Star acquisition is critical for accurate navigation.

Dead Reckon Mode (DR)

If the ANS inertial platform fails, navigation may continue using dead reckoning. In DEAD RECKON mode the ANS computer navigates using heading from the INS, true airspeed from the DAFICS (M computer) and inflight winds filled by the RSO. Position error increases proportional to errors in these inputs.

SYSTEM ERRORS

Error values in Figure 4-2 are based on the high altitude flight profiles. Abnormal flight profiles (low-altitude, race-track, touch-and-go, etc.) may result in errors in excess of the listed values. The error values listed are

probable radial errors (CEP's); therefore, under normal system operation, the listed errors will be exceeded about half the time. When star tracking is lost, a residual position error may develop that will not be totally eliminated when star tracking resumes. It might take as many as 3 navigation position updates (depending on Schuler cycle period) and a steady C star light to eliminate the total residual error.

SYSTEM COMPONENTS

The navigation system has three major assemblies: the control and display panel, the portable chronometer, and the guidance group. The control and display panel (Figure 4-3), located on the aft cockpit right console, is used to activate the system, select modes of operation, insert and monitor navigational data, modify the mission flight plan, and observe operating status.

A portable chronometer, in the aft cockpit supplies Greenwich Mean Time (GMT) (accurate to one-hundredth of a second) and the Julian date to establish the orientation of the Earth in inertial space for astro-inertial operations. The chronometer is set in the base shop, using a time standard set up to receive WWV time signals. Day can be set up to 511, thus allowing use of the computer star catalog into the next calendar year. A fully-charged, self-contained battery permits timekeeping for up to 24 hours without other power. Chronometer outputs are enabled only when aircraft power is applied. There is a GO, NO-GO indicator on the chronometer. GO indicates that either external or battery power is available and that the chronometer is operable, but does not indicate that the correct day and time is set. NO-GO indicates that chronometer outputs are unreliable.

The guidance group contains the electronic and optical-mechanical equipment for navigation and avionics subsystems control. The guidance group is mounted in the fuselage aft of the rear cockpit to provide an upward 78-degree cone of vision for the star-tracking telescope. The axis of the cone is vertical

SECTION IV

NAVIGATION MODE PROBABLE RADIAL ERROR

NAVIGATION MODE	ALIGNMENT METHOD			
	GRD HOT START	RAPID	AIRSTART	GYROCOMPASS
ASTRO INERTIAL ⁴ ³	1.0 nmi	0.3 nmi (up to 10 hrs) ⁵	—	0.3 nmi (up to 10 hrs)
INERTIAL ONLY (with fixpoints every hour) ¹	5.0 nmi/hr	2 nmi/hr 1.28 nmi	—	2 nmi/hr 1.28 nmi
AIRSTART (without fixpoints)	—	—	after 2 hrs: 1.75 nmi	
(with 2 fixpoints in first hr 20 x 5 min apart) ¹	—	—	after 1 hr: 1.25 nmi	
DEAD RECKONING	² 55 nmi/hr (Depends on INS and DAFICS accuracy)			

¹ Using fixpoints ascertained to 1-nmi accuracy
² No alignment required - Accuracy only as good as inputs (W/V, Hdg, MV, TAS)
³ Without continuous star tracking, errors approaching inertial operation can develop
⁴ With current accelerometer null bias calibration
⁵ With heading entry accurate to 0.1 degree

F20-8211

Figure 4-2

when the aircraft pitch angle is 7-1/2 degrees. The guidance group includes an inertially stabilized platform and associated electronic and electromechanical components required to control (1) its attitude, (2) a star-tracking telescope, and (3) the electronic and electromechanical components for pointing, servo-controlling, and discrimination of telescope photo-detections. A digital computer computes auto-navigation, guidance and avionics control, and maintains a continuously updated account of navigational status and coordinate values. The computer also stores instrument and mathematical coefficients, predetermined data references that define stars, and the mission flight plan. The computer initiates and evaluates self-tests periodically throughout the operating interval. Software corrections to the star data are provided for: (1) the shock wave over the window that refracts the star light and (2) pressure and temperature gradients (differentials) acting on the window causing optical lens effects.

NAVIGATION CONTROL AND DISPLAY PANEL (NCD)

The NCD (Figure 4-3) on the aft cockpit right console controls the ANS.

NOTE

The positions of the ANS controls and the last pushbutton operations are recorded once each 0.832 seconds by the MRS. Events can be marked by using the ANS keyboard.

MODE Switch

The rotary MODE switch has seven positions:

OFF	Power is off except illumination power and chronometer power.
WARM UP	Power to temperature control circuitry and the computer.

NAVIGATION CONTROL AND DISPLAY PANEL

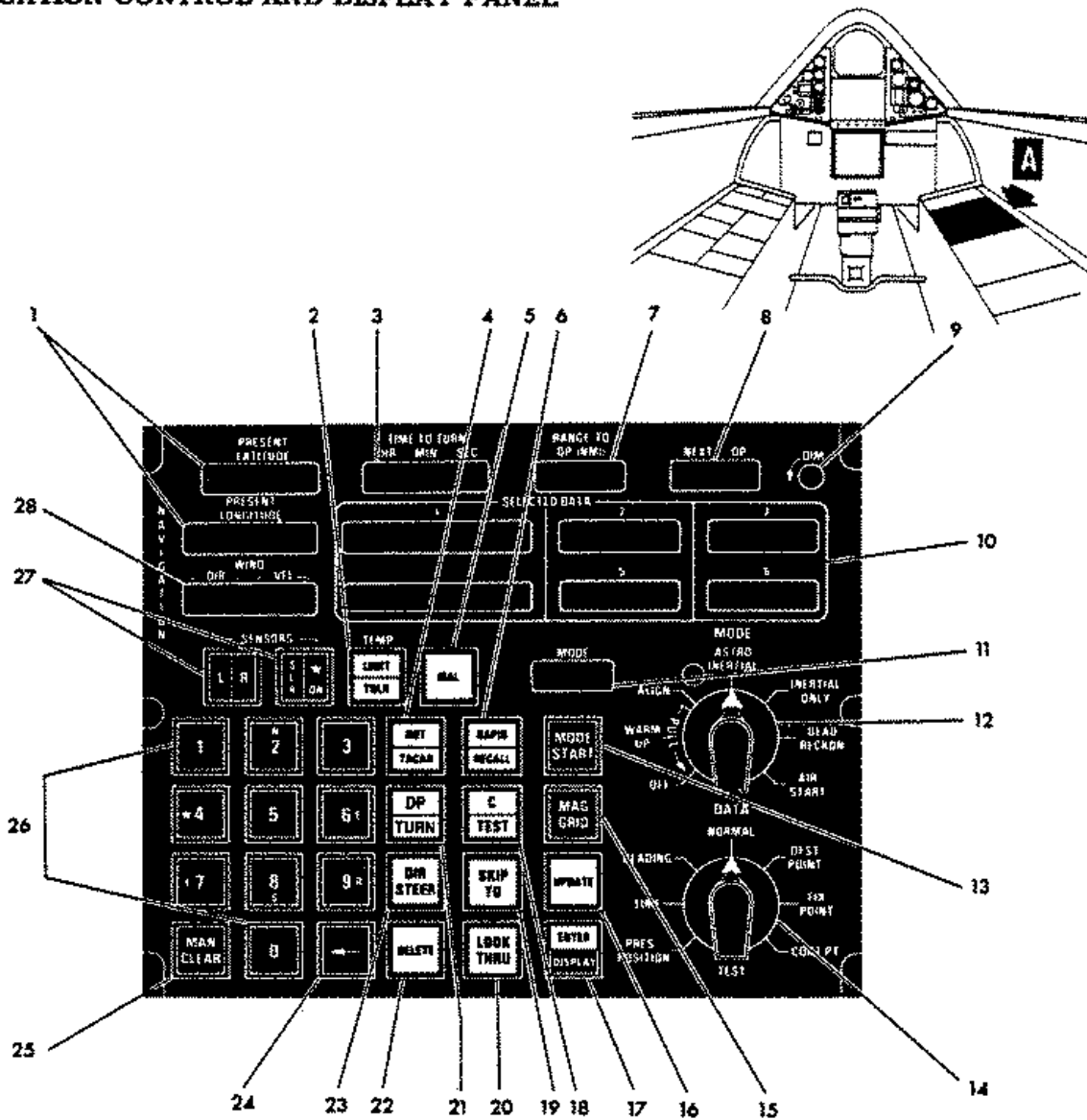

- | | | | |
|----|-----------------------------------|----|--|
| 1 | PRESENT POSITION WINDOWS | 15 | MAG/GRID SWITCH |
| 2 | TEMPERATURE MONITOR LIGHTS | 16 | UPDATE SWITCH |
| 3 | TIME-TO-TURN WINDOW | 17 | ENTER/DISPLAY SWITCH |
| 4 | HOT/TACAN SWITCH | 18 | C/TEST SWITCH |
| 5 | MALFUNCTION LIGHT | 19 | SKIP TO SWITCH |
| 6 | RAPID/RECALL SWITCH | 20 | LOOK THRU SWITCH |
| 7 | RANGE TO DESTINATION POINT WINDOW | 21 | DP/TURN SWITCH |
| 8 | NEXT DESTINATION POINT WINDOW | 22 | DELETE SWITCH |
| 9 | DIM SWITCH | 23 | DIRECT STEER SWITCH |
| 10 | SELECTED DATA WINDOWS | 24 | BACK SPACE SWITCH |
| 11 | MODE WINDOW | 25 | MANUAL CLEAR SWITCH |
| 12 | MODE SWITCH | 26 | MANUAL KEYBOARD AND POSITION PREFIX REFERENCE SWITCHES |
| 13 | MODE START SWITCH | 27 | SENSOR OPERATION INDICATOR LIGHTS |
| 14 | DATA SWITCH | 28 | WIND DIRECTION AND WIND VELOCITY WINDOWS |

F203-246(c)

Figure 4-3

SECTION IV

The following five modes are called "operate" modes, since power is applied to the entire ANS. Operation begins only after the MODE START, RAPID, or HOT switch is pressed.

ALIGN	Used on the ground to remain in fine alignment or for ground alignment correct procedure.
ASTRO INERTIAL	Selects astro-inertial navigation.
INERTIAL ONLY	Selects inertial-only navigation.
DEAD RECKON	Selects dead-reckon navigation.
AIRSTART	Used to perform a cold airstart (in-flight alignment) which results in airspeed damped, astro inertial navigation.

The MODE switch has a detent that prevents switching to OFF or WARM UP from an "operate" mode without lifting the switch. A detent prevents moving the switch clockwise past AIRSTART.

MODE START Switch

After power on, pressing MODE START initiates a gyrocompass or cold airstart alignment. After alignment, pressing the self-illuminated switch enables the mode selected by the MODE and MAG/GRID switches.

MAG/GRID Switch

The MAG/GRID switch is an alternate-action switch. Either the MAG or GRID half of the switch is lighted at all times. The ANS computer interrogates this switch each time the MODE START switch is pressed.

Set the switch to MAG. There is no useable grid heading available to either cockpit with the SKN-2417 INS in normal operation. The ANS computer interprets the INS heading input as MAG heading and makes appropriate computations to provide a true heading value for the dead-reckoning reference frame.

DATA Switch

The rotary DATA switch is used to select a panel fill, update, display, or mission modification procedure. The position of the switch determines the first character (always alphabetical) of the SELECTED DATA (SD) window that expects data. The eight DATA switch positions are PRES POSITION, TIME, HEADING, NORMAL, DEST POINT, FIX POINT, CONT PT, and TEST.

Keyboard Switches

The ten numerical keyboard switches, labeled 0 through 9, are used to enter data into the ANS or to command display of ANS data.

MAN CLEAR Switch

Used to clear the SELECTED DATA windows if an error is made during a panel-initiated procedure, and to not use an ANS position, altitude, or runway-heading alignment update. It is also used in the ANS malfunction routines.

ARROW (Backspace) Switch

Used to erase filled data one digit at a time in reverse order prior to actuating an action switch such as ENTER.

LOOK THRU Switch

Used to display data pertaining to the destination point (DP) after the DP now approaching.

SKIP TO Switch

Used to command the ANS to skip to a selected DP from the current next DP.

RAPID/RECALL Switch

Used to select rapid ground alignment or to recall data for display of the previously panel-filled TACAN point.

DELETE Switch

Used to delete a particular panel-filled

SECTION IV

DATA IN SELECTED DATA WINDOWS FOR PANEL ROUTINES

PANEL ROUTINE SEL- ECHO DATA WINDOW	FILE RUNWAY HEADING ALIGNMENT	FILE PRESENT POSITION AND INITIAL ALTITUDE	FILE WIND	FILE DAY AND TIME	FILE MAGNETIC VARIATION	FILE CHART CONVER- GENCE FACTOR	UPDATE HEADING	UPDATE PRESENT POSITION USING REMOTE SOURCE DATA	UPDATE PRESENT POSITION USING RADAR	UPDATE PRESENT POSITION USING VIEWSTIGHT	UPDATE PRESENT POSITION USING TACAN	UPDATE TRACK LEG
1	Computed runway true heading XXX° XX, X'	Latitude, N/S XX XX, XX'		GMT, XX hours XX minutes XX seconds				North-South error, nautical miles, N/S XXXX, XX	North-South error, nautical miles, N/S XX, XX	North-South error, in nautical miles, N/S XX, XX	North-South error, in nautical miles, N/S XX, XX	
2												
3		Altitude in hundreds of feet, XXX										
4	Filed runway true heading XXX° XX, X'	Longitude E/W XXX° XX, XX'			Magnetic variation E/W XXX° XX, X'		Heading XXX° XX, X'	East-West error, nautical miles, E/W 000 XX, XX	East-West error, nautical miles, E/W XX, XX	East-West error, in nautical miles, E/W XX, XX	East-West error, in nautical miles, E/W XX, XX	
5			Wind direction XXX									
6			Wind speed in knots, XXX	Julian day, XXX		Chart convergence factor X, XXX'						All five digits of point - ID code, D, XXXX

FIG-2516a

Figure 4-4 (Sheet 1 of 2)

DATA IN SELECTED DATA WINDOWS FOR PANEL ROUTINES

PANEL ROUTINE SEL. TECHNICAL DATA WINDOW	DIRECT SHEER	SKIP TO DP	DELETE FP, CP, DP	ADD OR REPLACE FP, CP, DP	NORMAL DISPLAY	DISPLAY NEXT FP, CP, DP	DISPLAY SELECTED FP, CP, DP	DISPLAY HEADING	DISPLAY DAY OF YEAR/STAR DATA	DISPLAY PRESENT POSITION	DISPLAY LOOK THRU	DISPLAY TAPE NUMBERS/ TEST
1	Latitude if new point is stored, NIS XX' XX.XX'			Latitude, NIS XX' XX.XX'	GMT in XX hours, XX mins, XX seconds	Latitude, NIS XX' XX.XX'	Latitude of alternate present position frame, NIS XX' XX.XX'	Velocity vector heading, VXXX' XX.X'	GMT in XX hours, XX mins, XX seconds	Latitude of alternate present position frame, NIS XX' XX.XX'	Latitude of DP+1 frame, NIS XX' XX.XX'	I-TIMWACC T - Tape M - Mod C - Corr
2				Range to DP, RXXX.X nmi Start range, I-TACAN FP SXXX.X nmi Along track range to CP, FP, AXXX.X nmi	True airspeed in knots, TXXX	Range to DP, RXXX.X nmi Start range, I-TACAN FP SXXX.X nmi Along track range to CP, FP, AXXX.X nmi	Great circle range for CP, DP, FP, AXXX.X nmi Start range, I-TACAN FP SXXX.X nmi	Grid heading, GXXX.X°	Star number, SXX		Along track range to DP+1, R XXXX nmi	MISSION Tape No. CXXX O - # or A thru Z or a thru *
3				Terrain elevation in hundreds of feet for CP's or FP's, XXX	Next FP No., FFI XXXX	Turn radius to DP, RXXX nmi Terrain elev for CP, FP, hundreds of feet, XXX	Turn radius to DP, RXXX nmi Terrain elev for CP, FP, hundreds of feet, XXX	Chart convergence factor, CX.XXX	Scan Rate Code, R X	Max altitude in hundreds of feet, AXXX	Turn radius of DP+1, R XXX nmi	General instrument constants tape NO., CXXX
4				Longitude, E/W XXX' XX.XX'	Aircraft cross track position, magnetic miles, I/R XXX, X	Longitude, E/W XXX' XX.XX'	Longitude (CP, XXX' XX.XX')	Aircraft true heading, XXXX' XX, X'	Time in this star search, T XX,XX min.; sec	Longitude of alternate present position frame, E/W XXX' XX.XX'	Longitude of DP+1, E/W XXX' XX.XX'	
5				IR, XX, 0 SLR code or I/R, 0 for CP, FP or I/W, XX, X may not apply for I-TACAN FP's.	Aircraft Ground Speed in knots, GXXXX	Relative bearing to DP, CP, FP, I/R XXX, X' Magnetic bearing to I-TACAN FP, BXXX, X'	Relative bearing to point, I/R XXX, X' Magnetic bearing, I-TACAN FP, BXXX, X'	Magnetic variation, E/W XXX, X'	Number of 10's acquired, AXXXX	Sun angle in degrees, III position, SXX, X'	Time to DP+1, TXXX.X min	TYVI (Normal) TYTZ (Trajectory) Where YY-year
6				Point ID Code, D XXXX C/CXXXX E/IXXXX	Next CP No., C/IXXXX	ID code of next point, D XXXX C/CXXXX E/IXXXX	ID code of next point, D XXXX C/CXXXX E/IXXXX	Magnetic heading, MXXX'	Julian day of year, DXXX II-III	Sun angle in degrees, III position, SXX, X'	DP+1 ID No., D XXXX	Test ID indication, T 0

Figure 4-4 (Sheet 2 of 2)

SECTION IV

Star ON Indicator Light

The light indicates the status of star tracking as described in the Computer Program section. Steady illumination of the light indicates that a minimum of two different stars have been tracked within the last 5 minutes.

MODE Window

The MODE window displays a legend which shows the operating phase of the ANS. The MODE window also displays an error message in the event of an operator error and may indicate recommended action in case of system malfunction. The malfunction indications are described in the Malfunction Indicator and the ANS MALFUNCTION PROCEDURES paragraphs. The MODE window indications are:

<u>Indication</u>	<u>Operating Phase</u>	<u>Definition</u>
C/A	COARSE ALIGN	Initial phase of ground or air start alignment.
F/A	FINE ALIGN	Final phase ground alignment.
RES	RE-START	Second phase of air-start or ground hot start alignment.
A-I	ASTRO INERTIAL	Astro inertial navigation.
I/O	INERTIAL ONLY	Inertial-only navigation.
D/R	DEAD RECKON	Dead-reckon navigation.
ENT		Coarse align complete. Enter present position or heading.
ERR		An operator error in panel operation has been committed.
ENC		Encoding failure.

DP*

Mission tape program sequence in error.

BLANK WARM UP Mode switch is in WARM UP and 28 volts dc is present.

Temperature Limit/Tolerance Indicator

The temperature limit and tolerance indicator, labeled TEMP LIMIT/TOLR is a split-function indicator which displays monitored cooling air flow and system internal temperatures. The top half of the indicator is red with the LIMIT legend visible when lighted. The bottom half of the indicator is amber, with the TOLR legend (tolerance) visible when lighted. (Refer to ANS MALFUNCTION PROCEDURES.)

Malfunction Indicator

The ANS malfunction indicator, labeled MAL, is a red panel light that can be off, on-steady, or on-flashing. Generally, the MAL light is off during normal operation, on-steady when the ANS is in the WARM UP mode, and on-flashing when a system self test has failed. (Refer to ANS MALFUNCTION PROCEDURES for detailed description.)

COMPUTER PROGRAM

The basic instructions and constants for computer operation are contained in the main program tape which is loaded into the computer permanent memory. The computer program is loaded in two parts, a basic main program tape and a correction tape (if needed). In addition, a general instrument constant (GIC) tape, star catalog (SYY1, SYY2) tape, and mission tape are loaded. Each ASTRO INERTIAL (A-I) unit has its own GIC tape which defines gyro, accelerometer, resolver, etc. parameters unique to the respective A-I unit. Annual revisions are made to the star catalog tapes. The main program tape currently used is Tape 10639512 (Tape 12).

STAR DATA USAGE

STAR	DEFINITION	DATA USAGE
A	First star tracked after a hot or cold airstart, ground hot start, or after changing from A-I to I/O and back to the A-I mode.	Computational triad and platform are corrected but present position is not changed, so there is no perturbation in latitude, longitude, or auto nav.
B	Second star tracked after an A star, or First star tracked after a ground alignment.	Computational triad and platform are corrected and now in coincidence. Latitude, longitude and auto nav adjustments occur. Computational triad and platform are corrected but present position is not changed, so there is no perturbation in latitude, longitude, or auto nav.
C	First and subsequent star tracked after B star.	Platform and computational triad are corrected. Auto-Nav transients are allowed on first star C but suppressed on subsequent ones until a bank angle exceeds 5° or position fix inserted

Figure 4-5

Astro Inertial Navigation

The ANS operates in typical inertial navigation fashion. Outputs from two 2-axis gyros drive the platform gimbals to isolate three orthogonally mounted accelerometers from changes in aircraft attitude. The gyros and accelerometers are mounted on the platform's azimuth gimbal (stable element). The accelerometer outputs are components of aircraft velocity change. If the azimuth gimbal is not kept level, the accelerometers also measure a component of acceleration due to gravity and position errors are produced.

In INERTIAL ONLY, the computer uses the accelerometer outputs to calculate aircraft velocity and change in position, and gyro torquing rates. The gyro torquing rates (signals proportional to aircraft velocity plus earth's rate) are applied to the gyros to maintain the azimuth gimbal (and thus the accelerometers) level with respect to the earth. The success of inertial navigation is due to the fact that any system error eventually causes the accelerometers to go

off level and measure a component of gravity which introduces an error that tends to cancel the original error. For example, if an accelerometer develops a null shift that appears to be an aircraft acceleration to the north, the platform will be torqued to keep up with the apparent aircraft motion over the earth's surface. Thus if the platform were level, it becomes tipped off level resulting in accelerometer measurement of gravity which looks like aircraft acceleration to the south. This characteristic of inertial systems is called Schuler tuning.

The star tracking function improves knowledge of accelerometer orientation in azimuth and eliminates the effects of gyro drift. Star search is initiated when astro-inertial mode is selected after completion of alignment. Selection of the star is made by the computer as a function of latitude, longitude, day of year, time of day, aircraft pitch and roll, and location of the sun. Aircraft pitch and roll determine the orientation of the star tracker window. For a given latitude, longitude, time of day and year, a particular star should be at a particular azimuth and elevation. If

SECTION IV

the star tracker measurements show that the star is not at the expected azimuth and elevation, there is an error in computed latitude and longitude and/or an error in platform orientation. Since the telescope is mounted on the platform, the star tracker measures the angular difference between the physical triad formed by the platform axes and the computational triad formed by the vertical through the computed position and the calculated orientation of the platform in azimuth. Thus the system cannot directly distinguish between a computed position error and a platform orientation error but, based on statistical probabilities determined by prestored error models and flight dynamics preceding the measurement, (as modeled by a Kalman filter, described later) it will attempt to optimally adjust the various navigational parameters.

To aid in describing star tracker logic, stars are given arbitrary labels depending on if they are the first, second, or third star tracked after the beginning of an operation. These are listed in Figure 4-5 with definitions and a summary of the usage of star tracker measured errors. In all cases, the end result of tracking two different stars is to align the computational triad with the platform triad or vice versa. A single star cannot be used to correct all errors since errors about the axis from the platform through that star are not measured. After the initial two stars are acquired, the normal interval between loss of track from one star to tracking the next star is about 30 seconds at altitude. Since the platform is almost continually brought into alignment with the computational triad, gyro errors have an almost negligible effect. The predominant ANS errors are those due to gyro drift that develop before stars are acquired and when star tracking is interrupted such as during aerial refueling. The star tracking data is used to update computed values of gyro drift to minimize error growth during any subsequent lapses in star tracking.

Star selection, tracker scan rate, and search patterns depend on many factors and are all under computer control. The computer selects a star by going through the star catalog which is arranged in order of

decreasing star brightness until it finds a star that is within the window aperture, not within 10° of zenith (not within 5° of zenith for trainer aircraft), and not within $12\text{-}1/2^\circ$ of the sun. The tracker telescope is commanded to search for the selected star using a variable sized pattern which is symmetrical about the computed star position.

The star search pattern is an expanding rectangular spiral which starts at the side of the pattern and then passes across the computed star position. See Figure 4-6. Maximum A star pattern size is a function of search rate so that all A star searches are completed within 23 minutes.

If the star is detected during this search, confirmation and reconfirmation patterns are made. If these are successful, the star is considered tracked, and elevation and azimuth errors are determined by the star actual position relative to its computed position. Search and track operations are discontinued if the star moves out of the window, the sky is too bright, or a position update is performed. The computer then goes to the next brightest star available, except that when a position update is performed, star search begins at the top of the star list (brightest star).

There are four scan rates which can be used in star search. Scan rate depends on star magnitude and sky brightness. The fastest is used on a bright star in a dim background while the slowest is used on a dim star in a bright background.

The search patterns are chosen as a function of the type of alignment and whether an A, B, or C star is being searched. See Figure 4-6. This table also lists the star ON light activity during star tracking operations.

Star Tracking Techniques

The star ON light provides the RSO with a guide for actions (listed in Figure 4-7) to optimize star tracking. Star tracking is automatic but the operator can assist the system in overcoming conditions such as overcasts, changes of sky background brightness, long

SECTION IV

periods of ground time after system initialization to A-I mode, refueling, and periods when tracking is not being accomplished. The operator should attempt to commence tracking stars as soon as possible to prevent or eliminate position error growth.

Improving Star Tracker Scan Rates

The ANS uses different scan rates for the star tracker depending upon the lightness of the sky background around the computed star position. This sampling of background conditions is accomplished automatically prior to beginning each star search. The time it takes the ANS to acquire a star depends on the magnitude of ANS errors. In extreme cases approximately twenty minutes could be required to acquire an A star.

An active (optimum signal-to-noise) filter to the ANS increases the probability of star detection, improves the accuracy of angle measurement, reduces the time devoted to detection and tracking of each star, and increases position and heading accuracy.

By using position fixes or remote updates, the RSO can reinitialize star search at the top of the star list (brightest star). This provides a new sky background lightness measurement and a change in scan rate if sky background lightness has changed. The RSO should use this procedure when there is a noticeable improvement in background conditions and the star ON light is not illuminated.

The RSO should periodically note the star tracking performance as indicated by the star light and star data in the Time display. If star tracking performance is less than expected (intermittent or no star light) for the existing sky conditions, the RSO should display day of year and note star number and scan rate. He should perform a zero remote update or command A, B, C Star Search to select the brightest star available (indicated by a number equal to or less than that previously indicated in SELECTED DATA window 2). This action will match the scan rate to the current sky background condition. A slower scan rate than that previously observed indicates less than optimum sky

**CREW ACTIONS TO OPTIMIZE
STAR TRACKING**

CONDITION	ACTION
Search underway for A or B star.	Maintain straight and level flight.
Star ON light out.	Make maximum number of position checks.
Star ON light out after entering a good sky situation.	Restart star search by using zero remote update procedure.
Star ON light out more than 15 minutes after zero remote update procedure has been performed and good sky conditions prevail throughout.	Command star A tracking by changing mode to INERTIAL ONLY, then change back to ASTRO INERTIAL to increase search pattern size.
Preflight in hangar.	Select INERTIAL ONLY to terminate fine alignment. Select ASTRO INERTIAL after clearing hangar or cloud cover.

Figure 4-7

background conditions. If a star is not acquired, a repeat of these routines when the sky background improves could increase the scan rate thus improving the probability of star acquisition. The scan rates are selected by the computer based on sky background measurements in the vicinity of the star. There are four scan rates available and the one in current use is indicated in SELECTED DATA window 3 as a code R1 (1250), R2 (703), R3 (395) or R4 (222) (arc sec/sec) when using the Time display routine. A dark sky background increases the likelihood of tracking stars and induces a fast scan rate. Conversely, a bright sky background decreases the likelihood of tracking stars and induces a slow scan rate.



An example of when this procedure could assist star acquisition is: the system is put in A-I mode after completing ground alignment with haze or thin cirrus clouds; after takeoff and leveloff at 25,000 feet, the star ON indicator is not illuminated but the aircraft is now above all haze and cirrus. A zero remote update routine should cause the system to select a faster scan rate as a result of the darker sky background. In most cases, this will speed up star acquisition.

Commanding A and B Mode Stars

If a preflight alignment is performed while under cover, such as in a hangar, select the INERTIAL ONLY mode at the completion of fine alignment and remain in INERTIAL ONLY until clear of the covered area. This prevents false star acquisitions due to ceiling lights, etc. In this case the first star tracked after selecting ASTRO INERTIAL will be a B mode star.

The nominal error growth of the ANS in INERTIAL ONLY is based on pure inertial operation; that is, MODE in INERTIAL ONLY, disabling the tracker from star searching. The tracker slewing on top of the platform in search operation can induce further position error growth. Because of this, the operator should avoid leaving the ANS in the ASTRO INERTIAL mode when star tracking is not expected for 25 minutes or longer. Put the system in INERTIAL ONLY mode when star tracking is lost or is not expected for at least 25 minutes (e.g. during overcast conditions or operation behind a tanker.) Once INERTIAL ONLY has been selected, operation in this mode should be continued until suitable tracking conditions are encountered.

Above 60,000 feet, with nominal star availability and sun angle, the crew can expect A/B mode star acquisition in a few minutes after returning to the ASTRO INERTIAL mode.

NOTE

- o Return the ANS to INERTIAL ONLY mode prior to entering a critical sensor "take" area if the star ON indicator has not indicated A/B star acquisition. This will inhibit A/B star updates which would cause auto nav roll transients.
- o Although a star light generally indicates a bounded error of less than 1 nm, greater errors are possible. Computer and/or chronometer malfunctions have resulted in the star light being on when position error exceeded 10 miles.

Kalman Filter

The system employs a Kalman filter to optimally incorporate measurements from the star tracker, DAFICS M computer, and fixpoints to correct inertial system errors. The filter continually estimates the error state of 16 parameters:

1. Platform azimuth
2. Platform tilt axis 2
3. Platform tilt axis 3
4. Position error axis 2
5. Position error axis 3
6. Velocity error axis 2
7. Velocity error axis 3
8. Azimuth gyro drift rate
9. 2 axis gyro drift rate
10. 3 axis gyro drift rate
11. 2 axis accelerometer bias
12. 3 axis accelerometer bias
13. Telescope elevation bias
14. True airspeed scale factor
15. Axis 2 Wind
16. Axis 3 Wind

Each of these parameters has a calculated error probability which is initialized as a

SECTION IV

function of the type of alignment accomplished. During a ground alignment system position is monitored to detect deviations from the entered coordinates. These deviations are fed as measurements to the filter which utilizes them to refine the first ten listed parameters. When star measurements are obtained, the first thirteen parameters are refined, and when airborne, all sixteen elements are estimated and continually refined. Because of wind variability and the accuracy (+30 knots) of True Air Speed, the airspeed measurement has essentially zero influence on the first thirteen parameters except in the case of a cold and hot airstart. When fixpoint measurements are inserted by the operator, the filter adjusts the 16 parameters according to the ratio of their current estimated error state to the programmed accuracy of the fixpoint device (.25 n.m. for SLR, .5 n.m. for Viewsight, and 1.0 n.m. for TACAN). The system incorporates 100 percent of a fixpoint if the correction is more than 5.0 n.m..

Dead Reckoning

Dead reckoning is performed simultaneously and separately from inertial navigation. During normal operation in ASTRO INERTIAL or INERTIAL ONLY, the dead reckoning latitude and longitude do not appear to the RSO unless the display Present Position routine is performed. However, prior to continuous star tracking in a cold or hot air start, or when DEAD RECKON is selected, dead reckon data is used as the source of present position and heading for all displays, great circle navigation and guidance, and sensor control. DEAD RECKON is the only mode in which present position can be entered after navigation is started; this may be done as often as desired. When DEAD RECKON is selected, the ANS generates all its normal outputs and continues astroinertial or inertial only navigation so that the DEAD RECKON mode can be selected for training while permitting return to ASTRO INERTIAL or INERTIAL ONLY modes. In normal operation, when dead reckon data is not used for ANS outputs, the dead reckoned latitude, longitude, and difference between INS heading and ANS true

heading (magnetic variation), if applicable, are updated every four minutes using inertial data.

Dead reckoning is the process of computing change in position using heading, speed, and elapsed time. True airspeed from DAFICS (M computer) is used with RSO entered values of wind speed and direction to approximate ground speed. Heading is provided from the INS and is magnetic heading except that ANS inertial heading is used following coarse alignment in a hot or cold air start.

When INS mag heading is being used, the RSO must periodically fill local magnetic variation so that computed true heading will have minimum error. When dead reckon data is not being used, magnetic variation need not be filled since the ANS itself computes a new magnetic variation every four minutes.

MISSION TAPE PROGRAM

The mission profile is defined in terms of destination points (DP), control points (CP), and fix points (FP), and the sensor operations associated with these points. Destination points delineate the prescribed mission track; they are intersections of the intended great-circle legs. Control points and fix points permit automatic activation of imaging sensors, and fix points define preferred navigational references. The mission plan is loaded into the computer memory on a mission tape prior to preflight operations. The mission tape can be programmed to hold up to 127 DP, 127 FP, and 127 CP (381 total). Additional temporary memory is provided for 40 point modification operations, known as the "40-List". The modifications may be performed using the Control and Display panel anytime power is supplied to the panel. Up to 40 add and/or replace operations and unlimited skip-to operations, are provided. In addition, there are special Anytime and Opportunity fix point procedures which do not use the 40-List. The mission tape may include a primary flight plan with one or more alternate routes that the crew may elect to follow by exercising the skip-to, direct steer, or track leg update options. The add and replace options of the 40-List permit

additional alternate paths to be formulated, and allow last-minute changes to sensor activity on programmed legs.

The data loaded into specified cells of the computer memory are identified by function and order of use in the mission plan (D00003, C00007, F00021, etc.). Each point is further defined by its coordinates, its sensor-usage, applicable pointing parameters, and reference to the next consecutive point or points. The destination points reference the next point of all three classes. The information programmed for each type of point is listed in Figure 4-11.

Great-Circle Steering

The mission path is a sequence of great-circle legs computed on the basis of DP coordinates. The ANS supplies a steering (bank angle) command to the autopilot in all ANS navigation modes but it is usable only when all requirements for a "nav-ready" condition are present. In the autopilot AUTO-NAV mode, bank angle is commanded by the ANS to automatically guide the aircraft onto and along the preprogrammed flight path. The bank angle steering command is computed from aircraft cross-track position and velocity relative to the desired course. If the planner has scheduled a bank angle of 35° or less, the ANS will not command a bank greater than 35° , even if a higher bank is required to keep the aircraft on course. If the turn is planned above 35° (up to 42°) the ANS will command up to 45° to keep the aircraft on course.

If the AUTO NAV mode is engaged when the aircraft is considerably off track, the ANS will steer towards the desired track at a 30° intercept angle. Depending on current groundspeed, the ANS will compute where to initiate a turn to discontinue the intercept course and smoothly fair onto track. During supersonic cruise this point is approximately 20 nm off course.

Once on course, the aircraft should usually be within 300 feet of the commanded course, except in turns. Actual position of the track is dependent on ANS navigation accuracy.

ANS Steering Turn Modes

The mission planner can choose one of two different turn modes at each DP. These modes determine where the turn start to the next great circle leg will occur and the amount of bank angle commanded during the turn.

Auto-Range-To-Turn

The system computes the turn radius based on a 32° bank angle and the groundspeed at the start turn point. Once the turn is initiated, it is identical to the turn described in the Fixed-Range-To-Turn paragraphs.

Auto-Range-To-Turn should be used for subsonic turns to prevent high bank angles at heavy weights. Current groundspeed and the heading change from present course to next are used to compute and initiate an automatic turn (termed by the mission planners as Turn Start Automatic, or TSA). The TSA point varies since it depends on groundspeed. If actual groundspeed is different from planned groundspeed, the TSA will not occur where planned and the aircraft will not follow the turn line depicted on the strip map. However, if there are no other disturbances, the aircraft should make the turn at a 32° bank angle.

Fixed-Range-To-Turn

Fixed-Range-To-Turn is used by the mission planners for turns that indicate critical sensor legs and turns where strict adherence to the planned turn line is required. In this mode, the mission planner specifies a constant turn radius at a particular DP. The TSA point is a fixed distance plus a variable distance from the DP. The fixed distance is determined by the programmed turn radius and the change in course; it would be equal to turn radius on a 90° turn. The variable distance ranges from 0 to 4.5 nm, depending on groundspeed, and compensates for the distance required to roll into the turn. During the turn, commanded bank angle is the sum of two components. One component is the nominal bank required to achieve the programmed turn radius at the current

SECTION IV

TYPICAL DESTINATION-POINT PLAN

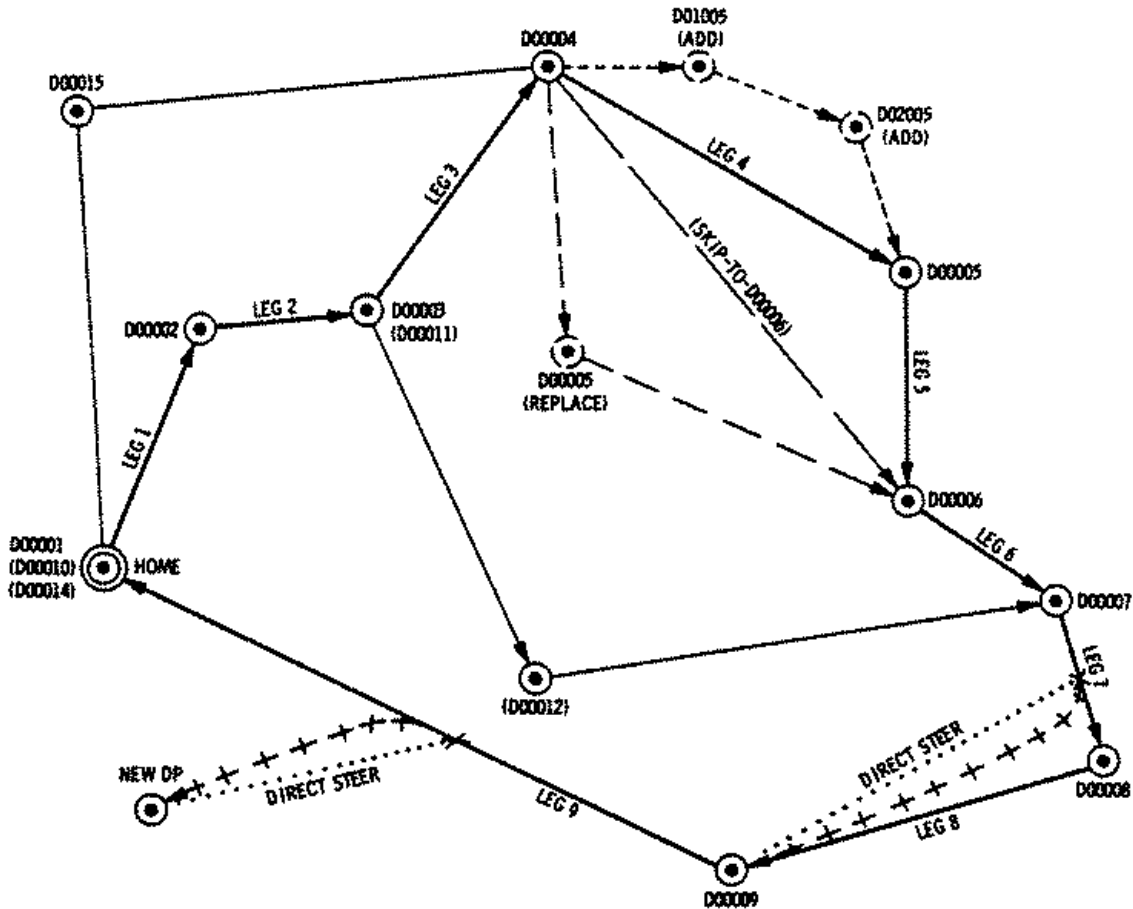

- TAPE-FILLED PRIMARY MISSION LEG
- TAPE-FILLED ALTERNATE MISSION LEG
- TAPE-FILLED DESTINATION POINT
- PANEL-FILLED DESTINATION POINT
- PANEL-FILLED SKIP-DP LEG
- PANEL-FILLED ADD-DP LEG
- PANEL-FILLED REPLACE-DP LEG
- ++++● PANEL OR TAPE-FILLED DIRECT STEER LEG

F200-204

Figure 4-8

ground speed. The second component trims bank angle trim as a function of the radial speed and position relative to the programmed radius so that the aircraft follows the planned turn line throughout the turn. If a transient causes the aircraft to deviate from the turn line, bank angle trim varies within $\pm 10^\circ$ to return to the turn line.

Range to destination as displayed on the HSI and the NCD includes distance around a turn rather than the length of the great circle from present position to destination. This distance around the turn is also used in computing time to turn for the NORMAL display.

TYPICAL ADD/REPLACE PLAN FOR FIX AND CONTROL POINTS

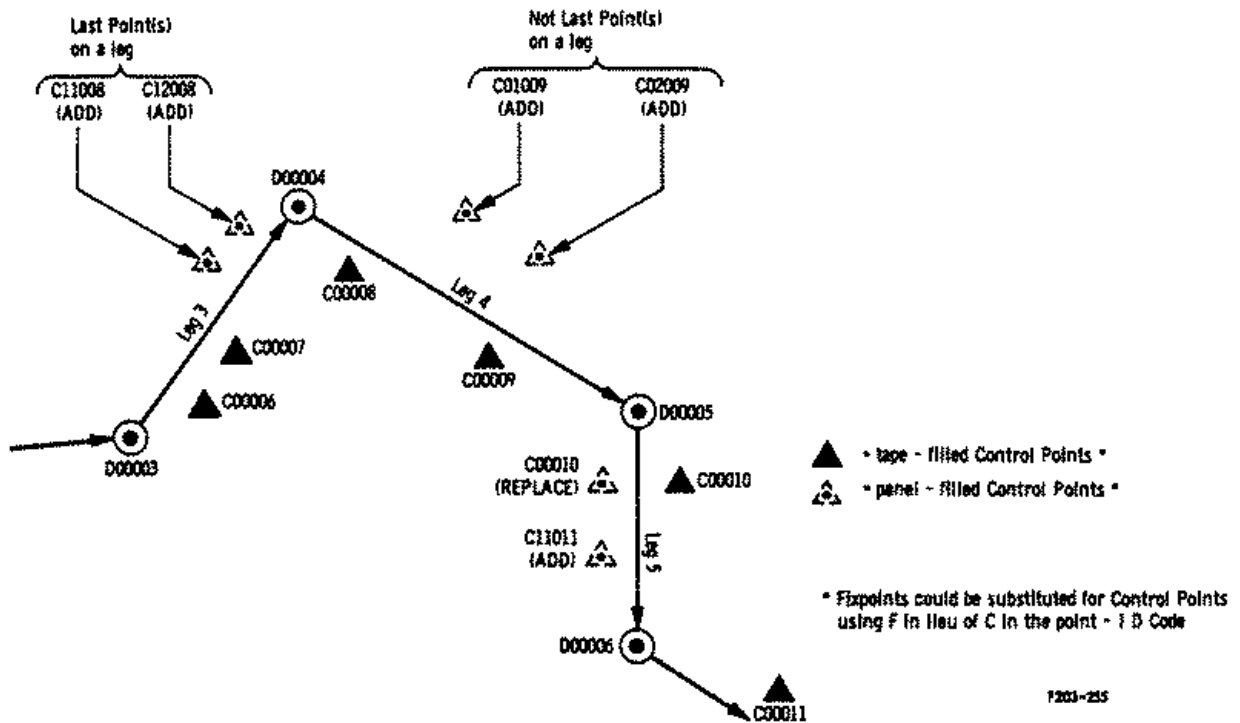

Figure 4-10

The radar remains on until a CP or FP commanding turn off occurs. RCD fixes are accurate to about 0.25 nm CEP.

For viewsight FPs, the RSO normally uses wide angle view to search for the FP as it approaches. After identifying the FP, select narrow view, if possible, for maximum accuracy. As the FP passes down the viewsight screen, move the cursor to intercept the FP as it passes under the nadir line. At that instant, press the viewsight READ switch. This provides the ANS with the location of the FP relative to the aircraft and allows measurement of ANS computed

position error. Again, the errors appear in north-south, east-west values on the NCD after the READ switch is pressed. Viewsight fixes are accurate to about 0.5 nm CEP.

At TACAN FPs, ANS computed values of slant range and bearing to a TACAN station are displayed on the NCD for comparison with TACAN data observed on the BDHL. When a TACAN fix is desired, depress the TACAN switch, then enter the TACAN values of magnetic bearing (xxx^o) and slant range (xxx nm) at the time the TACAN button was actuated. The ANS will then display the north-south and east-west errors.

SECTION IV

MISSION POINT DATA

	Dest. Point		Control Point		Viewsight or SLR FP		TACAN FP (1)
	Tape Filled	40-List	Tape Filled	40-List	Tape Filled	40-List	Tape Filled
Latitude	x	x	x	x	x	x	x
Longitude	x	x	x	x	x	x	x
Turn radius	(2)	(2)					
Next DP No.	x	(3)					
Next FP No.	x				x	(3)	x
Next FP on Track (yes/no)	x				x		x
Next CP No.	x		x	(3)			
Next CP on Track (yes/no)	x		x	x			
Left TEOC Mode			x	(4)			
Right TEOC Mode			x	(4)			
Camera/Radar			x	(5)			
Left TEOC (on/off)			x	x	x		x
Right TEOC (on/off)			x	x	x		x
Radar (on/off)			x	x	x		x
Left/Right TEOC			x	(6)			
Terrain Altitude			x	x	x	x	x
Radar Range Code			x	(5)	x	(7)	
Radar (narrow/wide)			x	(8)	x	(8)	
Radar (left/right)			x	(6)	x	(7)	
Radar to Radar FP					x	(9)	x
Radar/Viewsight FP					x	(7)	
TACAN/Not-TACAN FP					x		x
Magnetic Variation							x

NOTE:

An "x" in a column indicates that the corresponding parameter is programmed for that type of point.

- (1) There are no 40-list TACAN fix points. TACAN fix points are panel-filled as Anytime fix points which are not included on this chart.
- (2) Tape filled points: Zero turn radius used for auto-range-to-turn.

40-list points: No turn radius filled for auto-range-to-turn.
- (3) Point ID code is the 40-list equivalent to next point number. No point ID code entered for Anytime fixpoints or Opportunity Viewsight fix points.
- (4) Mode 3 is automatically used for 40-list camera points.
- (5) Camera/radar CP designation made by filling zero slant range code for camera points.
- (6) 40-list marker designates left/right camera for camera CP's, radar left/right for radar CP's.
- (7) Slant range code and left/right are not filled for viewsight FP's.
- (8) Only narrow modes can be used for panel-filled points.
- (9) 60 nm. is used automatically.

Figure 4-11

TACAN fixes are accurate to 2 to 3 nm at slant ranges from 20 to 200 nm. Accuracy is degraded at less than 20 nm and greater than 200 nm. The range data can generally be accepted, but TACAN bearing information may be somewhat inaccurate. When the INS is in the ATT mode, the TACAN mag bearing is correct, but the relative bearing may be in error.

If desired, the ANS computed position can be corrected by pressing the UPDATE switch; otherwise, press the MAN CLEAR switch to clear the measurement data. If FPs are used for updating, the ANS adjusts position, platform level, velocity, and heading based on the Kalman filter weighing matrices. The amounts applied to each of these parameters are optimized for the existing mode. Generally, corrections will not be necessary in the ASTRO INERTIAL mode although the measurement should be made to check the system.

Sensor operation may also be commanded at FPs. The point of execution will be at the along track position determined by the FP abeam point plus the range-to-turn-on value in the FP data of the mission tape. The TECH(s) may be turned on or off at any tape-filled FP. The camera(s) will be pointed and have the modes programmed at previous CPs. The SLR may be turned on or off at any tape-filled FP and may be repositioned if the FP is not a TACAN FP.

MISSION MODIFICATION

The tape-filled mission program can be modified through the NCD panel. Up to 40 sets of data (40-List) may be entered to replace or add to previously stored mission points. In addition, the operator can skip any number of tape-filled or panel-filled destination points, or change destination. There are also special panel-filled fixpoints called Anytime or Opportunity fixpoints that are exclusive of the 40-List.

Add or Replace CP-FP-DP Routine

The mission tape is stored in the tape-filled memory of the computer. Panel-filled data

for mission modification is stored in the panel-filled memory of the computer. Only Add or Replace modifications use the 40 panel-filled memory cells. Data required for each type of point, both panel-filled 40 List and tape-filled points, is listed in Figure 4-11. If necessary, the RSO can clear any or all of the mission modification data entered into the panel-filled memory and enter new data in the same 40 memory spaces. Detailed knowledge of the tape-filled mission is required to modify that mission, especially when control points or fixpoints are added or replaced.

Point-ID Code

Every tape-filled or 40-List mission point has an identification code. The code consists of a letter and five digits, referred to in the following text as digits 1, 2, 3, 4, and 5, counting from the left. This is the order in which the point-ID code is entered in the NCD panel. A letter C/CI, F/FI or D designates the point as a control point, fixpoint, or destination point, respectively, and appears in the left-most display of the SELECTED DATA 6 window when a mission point is selected for display. When modifying a mission, this part of the ID code is entered by selecting FIXPOINT, CONT PT, or DEST POINT on the DATA switch.

Digits 3 thru 5 of the ID code denote the number assigned to each tape-filled CP, FP, and DP. Tape-filled points are numbered from 001 for the first CP, FP, and DP, to 127. In general, the points on the primary mission are numbered in sequence followed by the points on alternate legs. However, the sequence is not really important since the next point number of each type is listed with each tape-filled mission point; i.e., the data for DP 002 can define DP013 as the next DP, or vice versa. The same applies to CP's and FP's.

As shown on Figure 4-8, DP's which are the start points for alternate legs are doubly defined. This means that the same geographic point is contained in two different locations with different number and different next-point numbers (example: D0003 and

SECTION IV

D00011). The alternate leg is selected by skipping to D00011 when on leg 1. Note that the alternate path rejoins the primary mission at D00007; thus, both D00006 and D00012 list D00007 as the next DP. 40-List (ADD or REPLACE) points are defined relative to tape-filled points; digits 3 thru 5 define the tape-filled point to be replaced, or the tape-filled or panel-replaced point following the point(s) to be added.

Digit 2 is the "add" number for panel-filled ADD points. Digit 2 can range from 1 to 7 for the first through seventh points to be added ahead of the tape-filled or panel-replaced point of the same type defined by digits 3 thru 5, where add point X10YZ is the first add point encountered in the mission, ahead of point 000YZ with add point X20YZ the second, etc. Digit 2 is zero for tape-filled points or replaced points. Digit 2 is the left-most digit in the SELECTED DATA window 6 when a mission modification is performed or a mission point is displayed.

Digit 1 is a zero for all tape-filled points, replaced control or fix points, and 40-list destination points. When adding fix or control points, however, digit 1 is used by the computer to determine the track leg location of the new added point. If the add point is after the last tape-filled point of its type on its track leg, this digit is 1; if the add point is before the last tape-filled point of its type on its track leg, then the digit is a zero. Digit 1 appears as C1 or F1 in the letter position of the SELECTED DATA 6 counter during a mission modification or mission point display operation (when ID code is entered). It also appears when a point is displayed.

Sensor Selection Code

The three-digit sensor selection code designates which sensor shall be turned on and/or remain on, at a panel-filled control point.

When control points are added or replaced, take care not to disrupt prior turn-on commands to the TECH cameras or SLR system. If, for example, the L TECH was automatically turned on 50 nm prior to an add R TECH control point, and the mission

SENSOR SELECTION CODE

SENSOR	CODE		
L TECH	1	0	0
R TECH	0	1	0
SLR	0	0	1

Verify code insertion on panel by illumination of appropriate sensor indicator.

Figure 4-12

planner intended it to remain on for a total 100 nm swath, the add-control point sensor assignment code would be 110. This would tell the computer to leave the L TECH on at the new control point and that the R TECH will be turned on. This is necessary because each CP will turn sensors off without an "on" marker in the sensor code.

Left-Right Start Range Code

The left-right marker and start range code (three digits in the range code column of Figure 4-13) designate which side of the aircraft to point and the distance from nadir to the area to be mapped (near edge of the radar beam, when the SLR is selected for use with fix-points or control points). The panel-filled start range code is limited to the SLR five-mile recorder strip width noted in the first column of the table. When adding or replacing TECH camera control points, insert L00.0 or R00.0 for control points to the left or right of course respectively. Verify code insertion in the SELECTED DATA window 5 (R or L plus three numeric digits).

40-List Add/Replace FP-CP-DP Limitations

Add/replace can be performed in any ANS mode except OFF or WARM UP. Add/replace alters the tape-filled mission. If the added point is located before the "next point" of each type on the current leg, or the replaced point is the current "next point" of

START RANGE CODE
-Capre Radar-

Ground Range Mapped (nm)	Range Code	Start Range (Cross Track Range to Near Edge of Beam (nm))
(Illegal Code)	L/R* 05	5
10 - 15	10	10
15 - 20	15	15
20 - 25	20	20
25 - 30	25	25
30 - 35	30	30
35 - 40	35	35
40 - 45	40	40
45 - 50	45	45
50 - 55	50	50
55 - 60	55	55
60 - 65	60	60
65 - 70	65	65
70 - 75	70	70

*L or R, depending on whether CP or FP is to the left or right of course.

Figure 4-13

each type, then the RSO must fill the new points into the 40-List and then perform a Track Leg Update. This will cause the ANS computer to recognize and use these new 40-List points. For example, if the first tape-filled leg is changed by replacing or adding DP's, a Track Leg Update will reinitialize the computer to the new first leg.

Any filled 40-List points located after the current "next tape-filled point" of each type will be utilized in the normal ANS sequence and no Track Leg Update is required (see Figure 4-10).

NOTE

A FP/CP/DP in the 40-List must be deleted before a correction/modification can be made to that numbered point.

Points may be added before replaced tape-filled DP's. A maximum of seven points of one type can be added in between two tape-filled points of that type. Points cannot be added after the last tape-filled point of that type. FP's and CP's cannot be added into track legs that contain no tape-filled FPs or CP's except an Anytime Fixpoint (described later) can be added to a leg that has no tape-filled FPs. If a FP is replaced, any sensor activity programmed at the original tape filled-point is negated, that is, will not occur. For example, if a camera was to be turned on at a radar FP or turned off, and that FP is replaced, the programmed camera activity will not take place. The sensors should then be operated in the Manual Mode. If a FP is added, there is no effect on the programmed camera activity. Adding a viewsight FP does not affect programmed radar activity.

The ANS does not automatically stop processing CP's and FP's on the original tape-filled leg when navigating on a leg from a tape-filled DP to an added or replaced DP; or from a replaced DP to any type of DP. In these cases, the CP's and FP's on the original leg are processed relative to the new leg. In general, pointing and mapping commands will be incorrect, and unless all CP's and FP's can be projected on to the new leg, a sensor could be commanded on but not off. Therefore, the sensors should be operated in their manual modes or tape-filled CP's and FP's should be replaced. No CP's and FP's are processed when navigating from an added DP to any type of DP.

After a power dropout, pressing RAPID or MODE START on the ground with the MAL light flashing will erase the 40-List. Anytime a rapid or gyro-compass ground alignment is performed, 40-List data must be re-entered. 40-List data is not deleted if the HOT switch is pressed with the MAL light flashing or a cold airstart is performed. Therefore, 40-List data is retained for a ground hot start, cold airstart, or a hot airstart. Pressing the MODE START switch without the MAL light flashing has no effect on the 40-List.

SECTION IV

Turn Radius For Panel-Filled DPs

A turn radius can be filled with any panel-filled DP to get a fixed-range-to-turn at that DP. This data is filled in nautical miles with three digits and appears in the SELECTED DATA window 3. If no turn radius is filled, the system calculates the turn radius based on current groundspeed and a 32° bank angle. Figure 4-14 lists turn radius values for various Mach numbers and bank angles.

NOTE

A turn radius for a bank angle greater than 35° will only be commanded by the autopilot if the original programmed bank angle for that turn start point (TSP) was greater than 35°. The autopilot will otherwise be limited to 35°.

Delete DP/FP/CP Procedure

The DELETE procedure can erase a panel-filled DP, FP, or CP from the 40-List so that the memory space can be re-used, or that a mistake in manually entering a point can be rectified without clearing the entire 40-List. Tape-filled points cannot be deleted.

Add FP Anytime Procedure

The ADD FP ANYTIME procedure is identical with the ADD-FP procedure except that no ID code is entered and the entry does not go into the 40-List. The procedure allows the RSO to add fixpoints on legs that have no tape-filled FPs (during critical phases of hot or cold airtasks; on skip-to or direct-steer legs; or any time).

The Anytime FP can only be entered when on the great-circle leg on which it is to be used. Actuation of the viewsight READ switch deletes either a viewsight or radar Anytime FP. A TRACK LEG UPDATE or DIRECT STEER procedure also deletes an Anytime fix point.

When a viewsight Anytime FP is inserted, no tape-filled or panel-filled fixpoints on that

track leg are processed until the RSO presses the viewsight READ switch. Camera and radar control points are not affected by the viewsight Anytime FP routine.

When a radar Anytime FP is inserted, the radar is commanded to operate 60 nm ahead of the Anytime point. Any tape-filled or panel-filled radar commands (CP's or FP) are inhibited and will not take place until 24 nm past the "Anytime" point. The radar remains on and pointed at the "Anytime" fix point until subsequent tape-filled or panel-filled radar commands turn the radar off or re-points it. Camera control points are not affected by the Radar Anytime FP routine.

TACAN Anytime FP's do not affect sensor programming at tape-filled control points or fixpoints. Therefore, for a confidence check on sensor "take" legs, it is better to use the Anytime TACAN or viewsight fix than the Anytime radar fix.

Opportunity Viewsight Fix

The Opportunity viewsight fix allows the RSO to update ANS present position using a visually identified point which has not been tape or panel-filled into the ANS. In this procedure the RSO aligns the cursor and presses the READ switch as in a normal viewsight fix routine. As the coordinates of the opportunity point are not previously stored in the computer, the initial display of ANS corrections is meaningless. However, these initial corrections are cleared when the RSO fills the latitude, longitude, and elevation of the opportunity point. When the ENTER/DISPLAY switch is pressed after coordinate entry, new errors are displayed. The RSO can then either clear the errors or enter the corrections.

The RSO can repeat the coordinate entry if an error is made in the initial entry by pressing the ENTER/DISPLAY switch and re-entering all data required. However, if ERR is displayed in the MODE window, MAN CLEAR must be pressed to terminate the routine and no update is possible.

Skip to DP Routine

The following examples refer to Figure 4-8.

When the skip-to routine is performed, the following DP number associated with the current next DP is replaced with the skipped-to DP number. This procedure can be used to select an alternate route in flight. For example, perform skip to D00011 while enroute from D00001 to D00002 and before reaching the range-to-turn to D00003, to select the alternate route from D00002 to D00011 to D00012, etc. This procedure could also be used to skip any portion of the programmed mission. For example, to skip from D00004 to D00006, perform a "skip to D00006" while enroute from D00003 to D00004 and before reaching the range-to-turn to D00005. Do not perform a skip from a doubly defined destination to its alternate destination since this creates a zero-length leg and unpredictable navigation results. For example, do not perform a "skip to D00011" after reaching the range-to-turn to D00003 and enroute to D00003 since the leg from D00003 to D00011 has zero length.

Skipping to a DP after starting great-circle navigation does not erase CP or FP operation on the original programmed leg following the current next DP. Consequently, skipping to D00011 to select the alternate route does not eliminate the sensor operation on the leg from D00002 to D00003. On the other hand, skipping to D00006 while enroute to D00004 will not eliminate the CP's and FP's along the original leg from D00004 to D00005, and the system will process these points. In this case, the sensors should be operated in their manual modes until back on the programmed mission course.

Direct Steer

The direct-steer procedure results in an immediate change in destination. When commanded, the ANS computes a new great-circle course from the present position to the destination point selected or coordinates entered by the RSO. The aircraft turns to

the new course immediately after the DIR STEER switch is pressed. The ANS computes new great-circle courses to the selected DP or coordinates until the aircraft has turned to within 2 degrees relative bearing to the destination. This results in the most direct path to the destination. If aircraft track subsequently deviates more than 2 degrees from command course, the direct steer is automatically restarted. When the DIRECT STEER procedure is performed, ANS operate commands to the sensors are turned off. The ADD ANYTIME FP and OPPORTUNITY Viewsight Fix procedures are usable while in DIRECT STEER if the aircraft track remains within 2 degrees of the bearing to the DP during the Fix procedure.

Track Leg Update

The Track Leg Update procedure allows the RSO to change the current ANS track leg. Any track leg segment in the mission may be selected. The RSO fills the ID code number of the beginning DP of the leg he desires. The ANS then initializes to the leg from that DP to the next sequential tape-filled or 40-List DP. Great-circle navigation and sensor control are immediately conducted relative to this new leg. The ANS sequences through all FP's and CP's on the new leg up to the current computed along-track position, where sensor commands will be as programmed for that point on the track; normal auto-nav steering is performed, using a 30-degree approach to the new track, if necessary.

The RSO should perform a track leg update during a Hot or Cold Airstart and Ground Hot Start since the computer automatically re-initializes to the first track leg segment on the mission tape at system turn-on.

NOTE

If the current groundspeed and/or present position satisfy turn start criteria to the next leg, then the ANS will accept the updated track leg and immediately "index" to that next track leg.

SECTION IV

ANS BANK ANGLE VS TURN RADIUS FOR VARIOUS MACH NUMBERS
FAT = -56°

Mach No. KTAS*	2.80 1606	2.85 1635	2.90 1664	2.95 1693	3.00 1721	3.05 1750	3.10 1779	3.15 1807	3.20 1836	3.25 1865
Bank Angle	Turn Radius (KR) - NM									
Deg.										
20	105	109	113	117	121	125	129	133	137	142
21	100	103	107	111	114	118	122	126	130	134
22	95	98	102	105	109	112	116	120	124	127
23	90	93	97	100	103	107	110	114	118	121
24	86	89	92	95	99	102	105	109	112	116
25	82	85	88	91	94	97	101	104	107	111
26	78	81	84	87	90	93	96	99	102	106
27	75	78	80	83	86	89	92	95	98	101
28	72	75	77	80	83	85	88	91	94	97
29	69	72	74	77	79	82	85	87	90	93
30	66	69	71	74	76	79	81	84	87	89
31	64	66	68	71	73	76	78	81	83	86
32	61	63	66	68	70	73	75	77	80	82
33	59	61	63	65	68	70	72	75	77	79
34	57	59	61	63	65	67	69	72	74	76
35	55	57	59	61	63	65	67	69	71	74
36	53	55	56	58	60	62	65	67	69	71
37	51	53	54	56	58	60	62	64	66	68
38	49	51	52	54	56	58	60	62	64	66
39	47	49	51	52	54	56	58	60	62	64
40	46	47	49	51	52	54	56	58	60	61
41	44	46	47	49	50	52	54	56	57	59
42	42	44	46	47	49	50	52	54	55	57
43	41	42	44	46	47	49	50	52	54	55
44	40	41	42	44	45	47	49	50	52	53
45	38	40	41	42	44	45	47	48	50	52

*KTAS based on Mach 1.0 = 573.6 knots at -56.5°C ambient air temperature.

KR = 14.815 (V/1000)² / Tan θ for ANS System turn; where V = KTAS, θ = bank angle.

Figure 4-14

ANS OPERATION

The ANS must be warmed up and aligned before flight. The methods for ground and air alignment and their association with various navigation modes is outlined in Figure 4-16.

Prior to ground alignment, verify that the prescribed mission program is in the computer and that the portable chronometer is installed and operating. Power and cooling air are required continuously through warm-up, alignment, and navigation. Once alignment has started, a power interruption of

ANS TURN RADIUS VS. TRUE AIRSPEED & BANK ANGLE

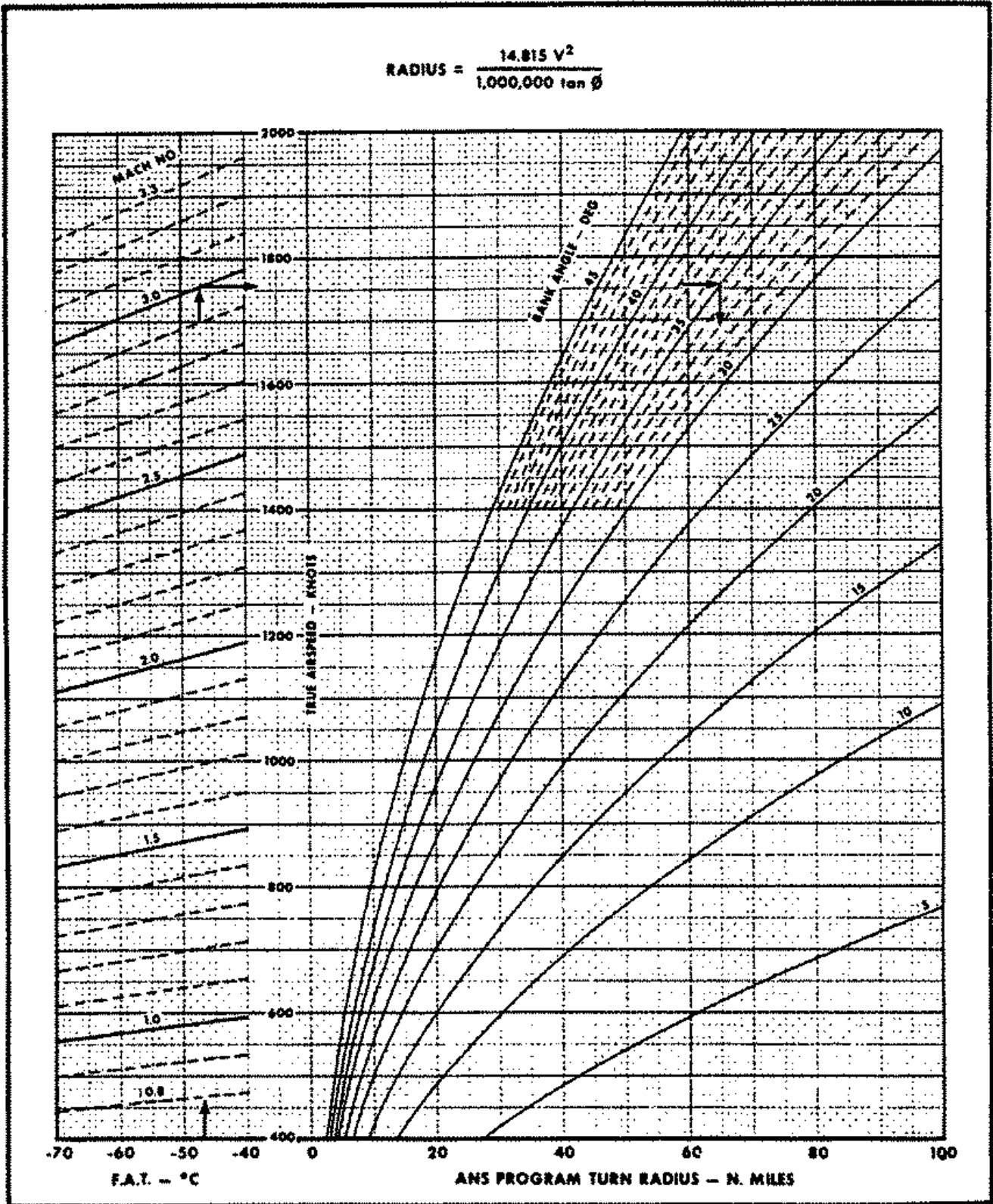

Figure 4-15

SECTION IV
NAVIGATION MODES VS ALIGNMENT METHODS

NAVIGATION MODE		ALIGNMENT METHOD WITH NDC -1070 COMPUTER
GROUND ACTIVATION	ASTRO INERTIAL INERTIAL ONLY	GYROCOMPASSING - Warm up 60 min - Coarse align 6 min - Fine align 29 min 55 sec 1st align - 12 min 15 sec slew 90° - 1 min 30 sec 2nd align - 16 min 10 sec } 95 min 55 sec RAPID - Warmup 60 min - Coarse align 6 min - Fine align 12 min } 78 min 15 sec GROUND HOT START - Coarse align 50 sec - Restart 30 sec } 90 sec
INFLIGHT ACTIVATION	AIRSTART	AIRSTART - Coarse Align Phase Until platform is rough leveled (< 40 arc min) - Restart Until platform is leveled (< 21 arc min) - Navigate Phase Continuous after platform leveling Dead Reckon Continuous from FILL PP (during coarse align) to ★ ON (steady) Search for Star A & B Continuous from platform leveling + 5 min to ★ ON illumination (steady) Airmass-damped, astro inertial navigation Continuous after ★ ON illumination (steady)

Figure 4-16

F203-254e1

more than 1 second will require realignment. Normally, warmup and alignment are performed on ground power and cooling air with transfer to aircraft power and cooling air after engine start, but can be performed on aircraft power and cooling air after engine start.

When operating from an alternate base without ANS support personnel, the chronometer day/time accuracy must be checked. If a flight with an accurate chronometer installed terminates at an alternate base, the chronometer can be (a) maintained indefinitely in an accurate GO state by connecting ground power and cooling to the aircraft with the MODE switch OFF and the aft cockpit ANS essential DC circuit breaker in, or (b) left in the aircraft after normal shutdown procedures are completed. In the latter case, if the battery ON/OFF switch is left in the ON position, the chronometer battery will

run down in approximately 24 hours and the chronometer will stop. After power is reapplied to the aircraft and the battery ON/OFF switch is in the ON position, the chronometer should display a GO status and begin to charge its internal battery. If the chronometer is in a GO status, but merely incorrectly set, fill DAY/TIME during C/A and operate in the ASTRO INERTIAL mode. (In a ground hot start, the C/A mode lasts only 60 seconds.) After filling DAY/TIME, the difference between RSO filled values and chronometer values is retained as a bias term to update the computer time following power dropouts of less than 1 second. Thus, astro inertial navigation should function normally. Power dropouts that exceed 1 second will not be compensated for.

After filling DAY/TIME a Hot Airstart cannot be performed and a new ground alignment or Cold Airstart is required. Chronometer options are listed in Figure 4-17.

(Note: 4-32A/(4-32E Blank) deleted

SECTION IV

Position fixes, using the TACAN, SLR, and viewsight should be made at frequent intervals to verify and, if necessary, refine computed position. The ANS errors measured by these systems are displayed on the NCD panel and may be cleared or entered into the ANS to correct present position. This is especially important in the alternate navigation modes.

TACAN FP accuracy is inherently worse than the viewsight, radar, or ANS fixes, so updates of the ANS by TACAN should only be entered when the ANS is positively known to have large errors.

The ANS software will weight the correction according to prestored accuracy estimates for the type of fixpoint and its current estimate of ANS accuracy. Hence the update command by the RSO will result in only a portion of the displayed error being accepted. The Remote Update routine will, however, always make a total position update by the amount commanded. On other types of fix updates, if either the latitude or longitude correction requested is greater than 5 nautical miles, the total amount will be accepted.

The NCD panel star ON light is an important indicator during astro-inertial and airstart operation. If the star ON light is out during astro-inertial operation, system error will increase at the inertial-only rate and extra effort should be made to check computed position. If the star ON light is on, astro-inertial performance will generally be good. Refer to Astro-Inertial Navigation, this section.

Airstart Alignment

Should there be an airborne power interruption or temporary malfunction, it may be possible to realign the ANS using the airstart procedure. A period of coarse alignment to level the platform is followed by a period when it may be possible to

accurately level the platform for precision navigation by performing a series of fixes.

Present position can be entered any time after initiating the airstart procedure and is updated continuously thereafter by dead-reckoning computations. If present position has not been filled by the time the coarse align phase has been completed, the MODE window will indicate ENT (Enter data).

The system also commences great-circle navigation and sensor control using dead reckoning position as a reference in computing steering commands, true heading, range and bearing to points of interest, NORMAL display data, etc. True heading must be checked for accuracy and updated as required. Magnetic variation may be used to correct true heading when the ANS is in the C/A mode. Afterwards the TRUE HEADING UPDATE routine must be performed. Also, if accurate navigation is desired prior to star ON light illumination, the FILL WIND procedure should be used initially in the coarse align mode and repeated as wind conditions change until star ON steady illumination. Position fixes (TACAN, viewsight, or radar) may be used to update the dead reckon frame during this period. Remote updates may be used to update the inertial frame.

After coarse alignment is completed, the MODE window display changes to RES and the system commences internal airspeed-damped navigation using dead-reckon data as a starting point. In one minute the first airmass damping correction is made and corrections of diminishing magnitude are made every minute for the duration of the flight. These corrections do not cause auto-nav steering transients. Inertial present position can be displayed and compared with dead-reckon present position by using the DISPLAY PRESENT POS procedure. Star search begins when A-I appears in the MODE window. To optimize star acquisition, the aircraft should be flown straight and level.

Acquisition of star A is indicated by flashing of the star ON indicator. When B star is acquired the star ON light goes out.

When the star ON indicator goes on steady, indicating that continuous star tracking is in

progress, inertial data is used to update all ANS outputs and internal dead-reckon computations. If the autopilot is engaged in the auto-nav mode, an aircraft maneuver will occur. Position fixes should be made and the system updated as required.

SECTION IV

ANS NORMAL PROCEDURES

The following ANS Tape 12 operating procedures are divided into the general categories of alignment, fill, update, change and display.

NOTE

In these procedures, only the indications that change as a result of procedural steps are listed. Assume that the display does not change if the indication of a particular display is not listed.

The L and R TECH and SLR NCD indicators will be off unless otherwise specified.

The MAL indicator must be off at all times except: it must be on steady while in the WARM UP mode and flash when the MODE switch has been turned from OFF or WARM UP to ALIGN, ASTRO INERTIAL, INERTIAL ONLY, DEAD RECKON, or AIRSTART; and must extinguish after the MODE START, HOT, or RAPID switch is pressed. Refer to the Emergency Procedures paragraph if the MAL light illuminates under any other circumstances.

"Operate" positions of the MODE switch means ALIGN, ASTRO INERTIAL, INERTIAL ONLY, DEAD RECKON, or AIRSTART.

If ERR is indicated in the MODE window, press the MAN CLEAR switch and restart the procedure.

ENT is displayed following the minimum coarse alignment period when present position/heading has not been filled.

When the MAN CLEAR switch is pressed (or the first keyboard switch is pressed after a panel routine is completed in a sequence of routines) the SELECTED DATA counters blank with the exception of a cue letter in one of the windows which will indicate the first data to be entered. The exact letter and window will depend on the DATA switch position. The PRESENT LATITUDE/LONGITUDE/WIND/NEXT DP/TIME TO TURN displays and the star ON, TEMP LIMIT, and TEMP TOLR indicator lights are not affected.

GROUND ALIGNMENT

Prior to ground alignment, an operating chronometer must be installed, the aircraft must be stationary, and the MODE switch must be OFF. Heading must be supplied within ± 28 degrees for gyrocompassing alignments, or ± 2 degrees for rapid alignment by the INS or TRUE HEADING UPDATE procedure.

1. MODE switch - WARM UP.
 - a. MAL light - On steady.
 - b. MODE window - Blank.

- c. TEMP LIMIT light - Off.

Turn MODE switch to OFF if TEMP LIMIT light illuminates.

- d. TEMP TOLR light - Off, on, or flashing.

2. MAG/GRID switch - MAG illuminated.
3. MODE switch - ALIGN, ASTRO INERTIAL, or INERTIAL ONLY.

Allow 5 minutes in WARM-UP before selecting an alignment mode.

- a. MAL light - Flashing
 - b. MODE window - C/A.
 - c. PRESENT LATITUDE and LONGITUDE windows - Blank.
 - d. SELECTED DATA windows - Blank.
4. Check GMT and Julian Day using TIME Display.

If either GMT or Julian Day are in error replace the chronometer and restart the alignment. If a chronometer replacement is not available, fill DAY and TIME as accurately as possible. Time error greater than 2 seconds may result in star tracking but with erroneous ANS updating. If accurate star tracking cannot be accomplished, the ANS may be operated in the INERTIAL ONLY Mode.

NOTE

The ANS may be initialized without TIME only if INERTIAL ONLY is selected and MODE START is depressed.

5. For GYROCOMPASS alignment: MODE START - Press or
- For RAPID alignment: RAPID Switch - Press
- a. MAL light - Off.
 - b. Star ON light - Flashing when artificial internal star is tracked.

If coarse alignment is completed before steps 6 through 8 are completed, MODE window will display ENT.

Perform step 6 or 7:

6. Use aircraft heading for TRUE HEADING UPDATE.

Enter known, accurate aircraft true heading, using the TRUE HEADING UPDATE procedure.

7. Use INS true heading for TRUE HEADING UPDATE.

Verify the INS is aligned and operating in NORM or NAV mode. Display INS true heading and insert these values into the ANS using the TRUE HEADING UPDATE routine.

NOTE

If the TRUE HEADING UPDATE routine is performed in coarse align or enter data, the updated true heading is used but will not be displayed until the ANS enters the fine align (F/A) mode.

When TEMP TOLR light off:

8. Fill present position and initial altitude (field elevation).

When coarse alignment is complete:

- a. For gyrocompassing alignment, MODE window displays F/A for at least 30 minutes.
- b. For rapid alignment, MODE window displays F/A for at least 12 minutes.

When the minimum alignment time has elapsed, present position is displayed in the PRESENT LATITUDE and LONGITUDE counters. After this occurs, and just before taxi, start navigation by performing steps 9 and 10.

Before taxiing:

9. MODE switch - ASTRO INERTIAL or INERTIAL ONLY.
10. MODE START - Press.
 - a. MODE window - A-I or I/O.

SECTION IV

NOTE

If ASTRO INERTIAL or INERTIAL ONLY mode was selected in step 3, the system automatically starts astro inertial or inertial only navigation, and the MODE window indicates A-I or I/O when the minimum alignment time has elapsed.

If rapid alignment used and star light off:

- 11. Do a RUNWAY HEADING ALIGNMENT.

NOTE

This step is not required if at least one star has been tracked (B star), however, this might not be evident unless the DATA switch was placed to TIME. In any case, the star on light (C star) indicates at least two different stars have been tracked within the past 5 minutes.

GROUND ALIGNMENT CORRECT

The GROUND ALIGNMENT CORRECT routine torques the platform to earth rate at the local latitude and thus removes any velocity errors that may have built up during taxi. If it is expected that the aircraft will remain stationary for at least four minutes after the star ON light has illuminated, this procedure should be used. Since star tracking continues during ground align correct, star tracking data is used to correct heading and recompute the accelerometer null bias point. This procedure is normally performed after engine runup and before taxiing to the runway. If the ANS is in the ALIGN mode during engine runs, inertial errors may result from inadvertant aircraft movement. A ground alignment correct need not be performed if the ANS is not tracking stars unless a long mission delay occurs. Although any built-up velocity errors will be removed, the accelerometer null bias point is not recomputed. Returning to ALIGN under this circumstance prevents further platform deterioration by

retorquing it to local latitude earth rate, but any errors present will continue to affect the platform after this procedure until star tracking occurs. If ALIGN is selected from the INERTIAL ONLY mode and if INERTIAL ONLY is reselected after ground align correct, the first star tracked after ASTRO INERTIAL is selected will be an A-star.

- 1. MODE switch - ALIGN.
- 2. MODE START - Press.
 - a. MODE window - F/A.

Prior to start of taxi, initiate navigation by performing steps 3 and 4.

- 3. MODE switch - ASTRO INERTIAL or INERTIAL ONLY.
- 4. MODE START - Press.
 - a. MODE window - A-I or I/O.

NOTE

If the ground-alignment-correct time is less than 10 seconds, no alignment correction is made.

GROUND HOT START ALIGNMENT

A ground hot start must be preceded by a ground alignment or navigation operation so that an accurate present position, altitude, and heading are stored in the computer. Following the previous operation, the aircraft must be stationary, no tape-fill operations can be performed, and the MODE switch must be in OFF or WARMUP. Prior to the hot start cooling air should be available (75°F) and an operating chronometer should be installed. If the system has not been turned OFF, skip to step 2.

- 1. MODE switch - WARM UP.
 - a. MAL light - On steady.

- b. MODE window - Blank.
 - c. TEMP LIMIT light - Off.
Turn MODE switch to OFF if TEMP LIMIT light illuminates.
 - d. TEMP TOLR light - Off, on, or flashing.
2. MODE switch - ASTRO INERTIAL or INERTIAL ONLY.
 - a. MAL light - Flashing.
 - b. MODE window - C/A.
 - c. PRESENT LATITUDE and LONGITUDE windows - Blank.
 - d. SELECTED DATA - Blank.
 3. Check GMT & Julian Day using TIME display.

If either GMT or Julian Day are in error, replace the chronometer and realign the ANS. If a chronometer replacement is not available, fill DAY and TIME as accurately as possible. TIME error greater than 2 seconds may result in star tracking but with erroneous ANS updating. If accurate star tracking cannot be accomplished, the ANS may be operated in the INERTIAL ONLY mode.
 4. HOT switch - Press.
 5. Check True Heading and present position.

NOTE

If true heading and/or present position are changed (or not accurate) since previous shutdown, turn system OFF and perform a Rapid or Gyrocompass alignment.

6. Use TRACK LEG UPDATE for initial DP.
7. MODE window - RES.

8. MODE window - F/A.

Before taxiing:

9. MODE switch - ASTRO INERTIAL or INERTIAL ONLY.
10. MODE START - Press.
 - a. MODE window - A-I or I/O.

When aligned on runway and no "A" star:

11. Do RUNWAY HEADING ALIGNMENT.

Not required if at least one star has been tracked (flashing star ON light).

COLD AIRSTART ALIGNMENT**NOTE**

If a power dropout has occurred, skip to step 3 if HOT or MODE START has not been pressed after power returns.

1. MODE switch - OFF.
 - a. All NCD panel lights & windows - Extinguished/Blank.
2. MODE switch - WARM UP.
 - a. MAL light - On steady.
 - b. MODE window - Blank.
 - c. TEMP LIMIT light - Off.

Turn MODE switch to OFF if TEMP LIMIT light illuminates.
 - d. TEMP TOLR light - Off, on, or flashing.
3. Adjust to straight and level flight.

Make necessary heading, altitude, and airspeed changes before continuing since the aircraft should be maintained as

SECTION IV

steady as possible throughout the air-start until the star ON illuminates, especially during C/A.

4. MODE switch - AIRSTART.
 - a. MAL light - Flashing.
 - b. MODE window - C/A.

NOTE

I/O appears in the MODE window if chronometer time and day are not available.

- c. PRESENT LATITUDE & LONGITUDE windows - Blank.
 - d. SELECTED DATA windows - Blank.
5. MODE START - Press.
 - a. MAL light - Off.
6. Check GMT & Julian Day using TIME Display.

If either time or day are in error, fill as accurately as possible. Time error greater than 2 seconds may result in star tracking but with erroneous ANS updating.

NOTE

If an error is made filling TIME and DAY, the routine may be repeated as long as the system is in C/A or ENT and the correct number of digits and ENTER/DISPLAY have been pressed first.

If accurate star tracking cannot be accomplished, select INERTIAL ONLY and press MODE START after the MODE window changes to A-I. If INERTIAL ONLY Mode is selected before C-star tracking, ANS present latitude and longitude will be DEAD RECKON coordinates. Monitor ANS attitude.

7. Check True Heading and Update if required.

An accurate True Heading should be displayed during C/A since the ANS uses the current INS magnetic heading and the last computed value of Δ PSIM, (this value normally equates to magnetic variation since it is the difference between the ANS inertial true heading and INS magnetic heading). If a heading error exists in the INS, Δ PSIM will be MAG VAR plus or minus INS heading error. Δ PSIM is updated every 4 minutes along with the DR position update and is also computed whenever ANS power is lost. If the aircraft does not fly through more than $1-1/2^\circ$ of variation from the time this value is computed until RES appears in the MODE window, the ANS heading should be accurate enough to track stars. If MAG VAR is filled, the computed value of MAG VAR (Δ PSIM) is superseded. A true heading error could result from adding a geographically accurate MAG VAR to an inaccurate INS magnetic heading. In any case filling MAG VAR will only change true heading and true heading display when in C/A. Fill MAG VAR has no effect on heading or heading display in RES or A-I. If a true heading update routine is performed during C/A or ENT, the updated true heading will not be displayed until RES. True heading may be updated and displayed in RES or A-I. The TRUE HEADING UPDATE routine will override the fill MAG VAR routine regardless of their sequence. The inertial frame uses the true heading at the end of C/A to begin inertial navigation.

The RSO has three options for true heading in the ANS: do nothing and let the last computed value of the MAG VAR (Δ PSIM) determine the true heading; fill a true heading (using tanker heading for example); or fill MAG VAR. If INS heading appears normal, the first option is recommended.

8. Fill Lat/Long of point ahead.

Insert latitude and longitude of a point to be overflown at a convenient distance ahead, using FILL PP procedure, but do not press ENTER switch until step 9.

9. ENTER switch - Press when over selected point.

PRESENT LATITUDE and LONGITUDE windows continually update, using dead-reckon data. Dead reckon data is used for great-circle navigation, sensor control, and all ANS outputs except pitch and roll which are not functional until the completion of coarse alignment.

10. Use TRACK LEG UPDATE or DIRECT STEER as required.

11. MODE window - Check for RES.

When MODE window changes to RES, C/A is complete.

- a. ANS pitch, roll, and heading outputs are now functional and reflect inertial data.
- b. Internal inertial navigation begins and inertial heading used for DR and heading.
- c. Auto-Nav usable, aircraft straight and level.

The autopilot can now be engaged, using ANS attitude reference. Any turns or attitude changes made during the RES mode will affect platform leveling and may prevent subsequent star tracking when the ANS goes into the A-I mode. Avoid engaging Auto-Nav in RES unless necessary.

12. Use DISPLAY PRESENT POSITION procedure to compare inertial and dead-

reckoning computations. Update dead-reckon present position using TACAN, viewsight, radar or PRESENT POSITION FILL procedures.

13. MODE window - Check for A-I.

MODE window display changes to A-I to indicate completion of true airspeed coarse leveling, beginning of star search, and the beginning of air-mass damping.

14. FILL WIND, as necessary.

NOTE

Wind can be filled for use in dead-reckoning navigation either in an airstart or when dead-reckon has been selected. Filling wind does not affect inertial navigation.

Perform FILL WIND procedure, as necessary, until star ON illuminates to keep the D.R. position accurate.

Use the REMOTE UPDATE routine to correct inertial position and re-initialize star search if inertial errors exceed 10 NM.

15. Check star ON light.

Acquisition of star A is indicated by flashing of the star ON light. When star B is acquired, the star ON light goes out. After the star ON light illuminates steady, inertial data is used to update all ANS outputs and internal dead-reckon data. If the autopilot is engaged in AUTO-NAV an aircraft maneuver will occur.

16. Update Present Position as required.

All inertial position error may not be yet removed even though the star light is illuminated.

SECTION IV

HOT AIRSTART ALIGNMENT

NOTE

If system has not been turned OFF, skip to Step 2.

1. MODE Switch - WARM UP.
 - a. MAL light - On steady.
 - b. MODE window - Blank.
 - c. TEMP LIMIT light - Off.

Turn MODE switch to OFF if TEMP LIMIT light illuminates.
 - d. TEMP TOLR light - Off, on, or flashing.

2. MODE switch - ALIGN, ASTRO INERTIAL, INERTIAL ONLY, or AIRSTART.
 - a. MAL light - Flashing.

NOTE

The flashing MAL light after a power dropout indicates power restoration and inertial position extrapolation occurs. Inertial position at the time power was removed is moved at TAS rate along the inertial heading at the time power was lost for a time interval equal to the period from power off to power on. This position extrapolation has nothing to do with when the RSO presses HOT. For 45-50 seconds after the MAL light begins flashing, nothing is done with the platform. At the end of this period, platform leveling begins if HOT has been pressed.

- b. MODE window - C/A. (If I/O, perform a COLD AIRSTART)

NOTE

If the MODE window display is I/O, turn the system off and perform a COLD AIRSTART. I/O appears in the MODE window if chronometer time and day are not available.

- c. PRESENT LATITUDE & LONGITUDE windows - Blank.
- d. Selected data windows - Blank.

3. Check GMT & Julian Day using TIME Display. If in error, perform a COLD AIRSTART.

If either time or day are in error, turn the MODE switch OFF and perform a COLD AIRSTART. Accurate position extrapolation cannot occur with erroneous time.

4. Adjust to straight and level flight.

Make necessary heading, altitude, and airspeed changes before continuing since the aircraft should be maintained as steady as possible throughout the airstart until the star ON light illuminates, especially during C/A.

5. HOT switch - Press.
 - a. MAL light - Off.
 - b. Present position windows - DR data.
 - c. Platform leveling is enabled.

6. FILL WIND, as necessary.

NOTE

Wind can be filled for use in dead-reckoning navigation either in an airstart or when DEAD-RECKON has been selected. Filling wind does not affect inertial navigation.

Perform FILL WIND procedures as necessary until the star light illuminates to keep DR position as accurate as possible.

7. Check True Heading and Update if required.

True Heading during C/A is INS heading and the last computed value of magnetic variation (Δ PSIM). This heading is used to drive the extrapolated Inertial position as well as the Dead Reckon position. Operation, display, and update of True Heading during C/A, RES, and A-I is identical to that during the COLD AIRSTART.

8. Check current track leg - Perform TRACK LEG UPDATE or DIRECT STEER, if required.

NOTE

An Auto Track Leg Update is initiated to the track leg on which the hot airstart is performed. If a direct steer had been performed on the leg on which the airstart is attempted then initialization will be to DP 1. SKIP TO operations initiated before a hot airstart are not retained.

9. MODE window - Check for RES.

When MODE window display changes to RES, C/A is complete.

- a. ANS pitch, roll, and heading outputs are now functional and reflect Inertial data.
- b. Internal inertial navigation begins and inertial heading used for DR and heading.
- c. Auto-nav usable, aircraft straight & level.

The autopilot can now be engaged, using ANS attitude reference. Any

turns or attitude changes made during the RES mode will affect platform leveling and may prevent subsequent star tracking when the ANS goes into the A-I mode. Avoid engaging Auto-Nav in RES unless necessary.

NOTE

If the platform precesses beyond $2-1/2^\circ$ of tilt from the time power is removed until the time platform leveling is enabled, the ANS will probably not come out of C/A into RES mode in a reasonable period of time and a COLD AIRSTART will have to be performed to level the platform.

10. MODE window - A-I.

MODE window display changes to A-I to indicate completion of true airspeed coarse leveling, and the beginning of star search, and air-mass damping.

NOTE

Even if the MODE switch is in ALIGN, INERTIAL ONLY, or AIR-START when HOT is pressed, the system will automatically go into ASTRO INERTIAL mode during a HOT AIRSTART.

11. Check star ON light.

Acquisition of star A is indicated by flashing of the star ON light. When star B is acquired, the star ON light goes out. After the star ON light illuminates steady, inertial data is used to update all ANS outputs and internal dead-reckon data. If the autopilot is engaged in AUTO-NAV, an aircraft maneuver will occur.

SELECT DEAD RECKON MODE

The DEAD RECKON mode can be selected any time in flight.

SECTION IV

1. MODE switch - DEAD RECKON.
2. MAG/GRID switch - MAG.
3. MODE START - Press.
 - a. MAL light - Off.

If on, refer to Emergency Procedures paragraph.
 - b. MODE window - D/R.
4. True Heading - Check, fill Mag Var as required.

Check true heading. Fill MAG VAR as required to keep the true heading as accurate as possible. When the DEAD RECKON mode is initially entered, magnetic variation should not have to be filled since the true heading will be the last computed value of Δ PSIM (the difference between the ANS inertial true heading and INS magnetic heading).
5. Fix and Update Present Position as required.

Fill present position if DEAD RECKON is selected from OFF or WARM UP.
6. FILL WIND, as necessary.

NOTE

Wind can be filled for use in dead-reckoning navigation either in an air start or when dead-reckon has been selected. Filling wind does not affect inertial navigation.

PRESENT LATITUDE and LONGITUDE windows are clear until filled if DEAD RECKON is selected from OFF or WARM UP, or during a "cold" airstart. Otherwise, the PRESENT LATITUDE and LONGITUDE counters are continuously updated from their initial reading as soon as MODE START is pressed.

The ANS assumes 0 degrees roll and 6 degrees pitch when VIEWSIGHT PP UPDATE procedure is performed in the DEAD RECKON mode; therefore, the aircraft should be straight-and-level for viewsight fixpoints. If another operate mode is selected from DEAD RECKON, even prior to star ON light illumination in a "cold" or "hot" airstart, dead-reckon position and magnetic variation are updated to inertial data at 4-minute intervals in the new mode.

RUNWAY HEADING ALIGNMENT

The aircraft should be aligned with runway centerline. MODE switch must be in ASTRO INERTIAL or INERTIAL ONLY position. MODE window display must match MODE switch position. A heading correction will be inhibited if star B was successfully acquired as the first star after ground alignment.

1. DATA switch - HEADING.
2. Runway True Heading - Enter (XXX° XX.X').

Enter known runway true heading in degrees (three digits), minutes (two digits), and tenths of minutes (one digit). Entered data appears in SELECTED DATA 4 window.
3. MODE START - Press.

Press just before takeoff roll.

At liftoff:

4. Check ANS computed True Heading in SD-1 window.

At aircraft lift-off, average ANS heading appears in degrees (three digits), minutes (two digits), and tenths of minutes (one digit).

Perform step 5 or 6:

5. UPDATE switch - Press.

Press to incorporate difference between average ANS and runway headings.

- MAN CLEAR switch - Press.

NOTE

If computed runway heading does not appear in SD-1 window at lift-off, the takeoff switch has probably failed; in this case, press MAN CLEAR to terminate the procedure.

FILL PRESENT POSITION AND INITIAL ALTITUDE

In any "operate" mode, when MODE window displays C/A, ENT, RES, A-I or D/R for other than initial fill for ground align.

NOTE

Either magnetic variation or true heading must be entered for ground alignment prior to FILL PRESENT POSITION and INITIAL ALTITUDE or an ERR indication will appear after ENTER is pressed.

If present position is filled in flight, position coordinates should be those that will exist when ENTER is pressed. Any present position filled after the COARSE ALIGN (C/A) phase will be entered into the dead reckon reference frame.

If not a ground Alignment, do steps 1, 2, 3, & 5:

- DATA switch - PRES POSITION.
- Fill Latitude (N/S XX°XX.XX')

Enter N or S position latitude in degrees (two digits), minutes (two digits), and hundredths of minutes (two digits). Entered data appears in SD-1 window.

- Fill Longitude (E/W XXX°XX.XX')

Enter E or W position longitude in degrees (three digits), minutes (two digits), and hundredths of minutes (two digits). Entered data appears in SD-4 window.

- Local Field Elevation - Enter (XXX) in hundred feet.

Entered data appears in SD-3 window.

- ENTER switch - Press.

FILL WIND

MODE switch in any "operate" mode. MODE window displays any mode.

- DATA switch - TEST.
- Wind direction - Enter (XXX°).

Entered data appears in SD-5 window.

- Wind speed - Enter (XXX).

Enter wind speed in knots (three digits). Entered data appears in SD-6 window.

- ENTER switch - Press.

FILL DAY AND TIME

Day and time may be filled only when the ANS is in COARSE ALIGN. Attempting to enter day/time in any other mode will result in ERR in the MODE window.

NOTE

The MODE window normally reads C/A or ENT when the ANS is in the C/A mode. Whenever the ANS has power restored after a power loss and chronometer day and time are not available, the ANS will be in the C/A mode although the MODE window will read I/O and the MAL light will be flashing.

SECTION IV

1. DATA switch - TIME.
2. Julian Day - Enter (ØXXX)

Enter Julian day of year (four digits).
Entered data appears in SD-6 window.

NOTE

Fill Julian day to correspond with GMT.

3. GMT - Enter (XX hr, XX min, XX sec).

Entered data appears in SD-1 window.
4. ENTER switch - Press & release at time back.

Filled day and time are entered when the ENTER switch is released.

NOTE

If an error is made in filling day and time the routine may be repeated as long as the correct number of digits and ENTER have been pressed first. If the MAL light is flashing in C/A and an error is made in filling day and time which results in ERR in the MODE window, press MAN CLEAR and reenter data.

FILL DAY

If a chronometer has the correct time but the wrong Julian Day, then a FILL DAY routine will be required during COARSE ALIGN to permit accurate star tracking.

1. DATA switch - TIME.
2. Julian Day - Enter (ØXXX).
3. ENTER switch - Press.

FILL MAGNETIC VARIATION

In any "operate" mode:

1. DATA switch - HEADING.
2. Variation - Enter (E/W XXX^ØXX.X').

Entered data appears in SD-4 window.
3. ENTER switch - Press.

NOTE

This routine is only functional if the system is in the MAG mode.

HEADING UPDATE

In any "operate" MODE:

1. DATA switch - HEADING.
2. True Heading - Enter (XXX^ØXX.X').

Entered data appears in SD-4 window.
3. UPDATE switch - Press.

If this procedure is performed during the coarse align mode, entered value of heading will be used to initialize system true heading. If performed during fine align or any navigate mode, entered value will replace existing true heading.

NOTE

Unless the system is in C/A, the ANS will accept a maximum heading update change of 28^Ø. For an update change greater than 28^Ø the routine will have to be repeated until the desired heading to be updated is within 28^Ø of the system's last known heading.

**PRESENT POSITION UPDATE,
USING REMOTE SOURCE DATA
(REMOTE UPDATE)**

The maximum allowable correction is 90 nautical miles. The correction always goes to the inertial frame regardless of system mode. A dead-reckoned position cannot be updated by this procedure. The correction moves the inertial frame by the desired amount, i.e., if the aircraft is 0.5 nm south of the known location, a remote update of N0000.50 should be performed.

In any "operate" mode:

1. DATA switch - PRES POSITION.
2. N or S Correction - Enter (N/S 00XX.XX nm).

Entered data appears in SD-1 window.

3. E or W Correction - Enter (E/W 000XX.XX nm).

Entered data appears in SD-4 window.

4. UPDATE switch - Press.

**PRESENT POSITION UPDATE,
USING RADAR WITH RCD**

MODE: ASTRO INERTIAL, INERTIAL ONLY, DEAD RECKON, or AIRSTART; MODE window displays any mode except F/A or ENT.

1. MOT switch - Press, S light On.
2. Radar crosshair - Place over ANS L mark intersection.

NOTE

As the aircraft passes abeam the programmed fixpoint, the MARK light appears at the bottom center of the RCD screen. This alerts the RSO of the impending L-mark. The light will remain illuminated for approximately 50 seconds after marker appearance. The light goes out when the L-mark is in the approximate center of the screen.

3. RCD Zero Control - Press, WAIT illuminated.

WAIT illuminates for 5 seconds. During this time do not move crosshair controls.

When WAIT extinguished:

4. Radar crosshair - Place over fixpoint.
5. READ ERR switch - Press.
 - a. North or south ANS-computed error in nautical miles (two digits), and hundredths of miles (two digits) appears in SD-1 window.
 - b. East or west ANS-computed error in nautical miles (two digits), and hundredths of miles (two digits) appears in SD-4 window.
6. MOT switch - Press, R light On.

Do step 7 or 8:

7. UPDATE switch - Press.

Automatically updates present position.

SECTION IV

8. MAN CLEAR switch - Press.

Bypasses updating of present position.

NOTE

The ANS automatically sequences to the following FP when the L mark is sent to the RCD, except on Anytime radar FPs when the sequencing occurs 24 nm past the FP.

PRESENT POSITION UPDATE, USING VIEWSIGHT

MODE: ASTRO INERTIAL, INERTIAL ONLY, DEAD RECKON, or AIRSTART; MODE window displays any mode except F/A or ENT.

1. Magnification - Select desired field of view.
2. Viewsight Cursor - Align with fixpoint.

When fixpoint under nadir:

3. READ switch - Press.
 - a. North or south ANS-computed error in nautical miles (two digits), and hundredths of miles (two digits) appears in SD-1 window.
 - b. East or west ANS-computed error in nautical miles (two digits), and hundredths of miles (two digits) appears in SD-4 window.

Do step 4 or 5.

4. UPDATE switch - Press.

Automatically corrects present position.

5. MAN CLEAR switch - Press.

Bypasses updating of present position.

The ANS automatically sequences to the following FP 17.25 nm past a viewsight FP.

PRESENT POSITION UPDATE, USING TACAN (TAPE FILLED POINT)

In any "operate" mode:

1. BDHI HDG Select switch - INS.
2. BDHI No. 1 needle select switch - TACAN.
3. Use Display Next FP, or Display Selected FP procedure.
4. TACAN switch - Press.

Press when TACAN system values have been noted on BDHL. All SELECTED DATA displays will clear.

5. TACAN mag bearing value - Enter (XXX^o).

Enter TACAN value of magnetic bearing from aircraft to station in degrees (three digits). Entered data appears in SD-5 window.

6. TACAN slant range value - Enter (XXX nm).

Entered data appears in SD-6 window.

7. ENTER switch - Press.
 - a. SD-1 window displays north or south ANS computed error in nm and hundredths of miles.
 - b. SD-4 window displays east or west computed error in nm and hundredths of miles.

Do step 8 or 9:

8. UPDATE switch - Press.

Automatically updates present position.

9. MAN CLEAR switch - Press.

Bypasses updating of present position.

The ANS automatically sequences to the next FP when 17.25 nm past a TACAN FP.

PRESENT POSITION UPDATE, USING TACAN (ANYTIME TACAN FP)

In any "operate" mode:

1. BDHI HDG select switch - INS.
2. BDHI No. 1 needle select switch - TACAN.
3. DATA switch - FIX POINT.
4. Fixpoint Latitude - Enter (N/S XX^oXX.XX')

Enter N or S and latitude of fixpoint in degrees (two digits), minutes (two digits), and hundredths of minutes (two digits). Entered data appears in SD-1 window. If any of the sensor operation indicator lights are illuminated, they extinguish when N or S is pressed. The automatic sensors continue to operate normally during the add anytime TACAN fixpoint routine.

5. Fixpoint Longitude - Enter (E/W XXX^oXX.XX')

Enter E or W and longitude of fixpoint in degrees (three digits), minutes (two digits) and hundredths of minutes (two digits). Entered data appears in SD-4 window.

6. Fixpoint Elevation - Enter (XXX).

Enter elevation of fixpoint in hundreds of feet (three digits). Entered data appears in SD-3 window.

7. Variation - Enter (E/W XX.XX^o).

Enter E or W magnetic variation of TACAN station in degrees and tenths of degrees of arc as follows: E or WXX.XX^o. Entered data will appear as follows:

- a. E/W in SD-5 window.
- b. Tens, units, and tenths of degrees in SD-5 window following E/W. Hundredths of degrees is not displayed.

NOTE

The maximum value of magnetic variation which can be entered is 99.99^o. ANYTIME TACAN fixpoints cannot be used if actual magnetic variation exceeds this value.

8. ENTER switch - Press.
 - a. SD-2 window displays computed TACAN slant range.
 - b. SD-5 window displays computed TACAN bearing.
9. TACAN switch - Press.

Press when TACAN system values have been noted on BDHL. All SELECTED DATA displays will clear.
10. TACAN mag bearing value - Enter (XXX^o)

Enter TACAN value of magnetic bearing from aircraft to station in degrees (three digits). Entered data appears in SD-5 window.
11. TACAN slant range value - Enter (XXX nm).

Entered data appears in SD-6 window.
12. ENTER switch - Press.
 - a. SD-1 window displays north or south ANS computed error in nm and hundredths of miles.

SECTION IV

- b. SD-4 window displays east or west ANS computed error in nm and hundredths of miles.

Do step 13 or 14:

13. UPDATE switch - Press.

Automatically updates present position.

14. MAN CLEAR switch - Press.

Bypasses updating of present position.

The ANS automatically sequences to the next FP when 17.25 nm past a TACAN FP.

RECALL ANYTIME TACAN FIXPOINT

MODE in any "operate" mode; an ANYTIME TACAN FIXPOINT must have been previously entered using the TACAN (ANYTIME TACAN FP) procedure. If more than one ANYTIME TACAN FIXPOINT has been entered, the last entered fixpoint will be recalled. Verify that the proper TACAN station is selected and that the TACAN T/R mode is set.

1. BDHI HDG select switch - INS.
2. BDHI No. 1 needle select switch - TACAN.
3. DATA switch - FIX POINT.
4. RECALL switch - Press.

NOTE

Step 4 will recall the last entered ANYTIME TACAN FIXPOINT. If there is none, the MODE window indicates ERR.

5. TACAN switch - Press.

Press when TACAN system values have been noted on BDHL. All SELECTED DATA displays clear.

6. TACAN mag bearing value - Enter (XXX^o).

Enter TACAN value of magnetic bearing from aircraft to station in degrees (three digits). Entered data appears in SD-5 window.

7. TACAN slant range value - Enter (XXX nm).

Entered data appears in SD-6 window.

8. ENTER switch - Press.

a. SD-1 window displays north or south ANS computed error in nm and hundredths of miles.

b. SD-4 window displays east or west computed error in nm and hundredths of miles.

Do step 9 or 10:

9. UPDATE switch - Press.

Automatically corrects present position.

10. MAN CLEAR switch - Press.

Bypasses updating of present position.

The ANS automatically sequences to the next FP when 17.25 nm past a TACAN FP.

PRESENT POSITION UPDATE, USING OPPORTUNITY VIEWSIGHT FIXPOINT

MODE in any "operate" mode; MODE window indicates any mode except C/A, F/A, or ENT.

1. Magnification - Set desired field of view.
2. Viewsight cursor - Align with fixpoint.

When Fixpoint under nadir:

3. READ switch - Press.

- a. SD-1 window - Meaningless number.
- b. SD-4 window - Meaningless number.
4. Fixpoint Latitude - Enter (N/S XX^oXX.XX').
Entered data appears in SD-1 window.
5. Fixpoint longitude - Enter (E/W XXX^oXX.XX').
Entered data appears in SD-4 window.
6. Fixpoint Elevation - Enter (XXX) in hundreds of feet.
Entered data appears in SD-3 window.
7. ENTER switch - Press.
 - a. North or south ANS computed error in nautical miles (two digits) and hundredths of miles (two digits) appears in SD-1 window.
 - b. East or West ANS computed error in nautical miles (two digits) and hundredths of miles (two digits) appears in SD-4 window.

NOTE

If an error is made when entering data (other than entering too many digits) press ENTER pushbutton and re-enter all data. If MODE window displays ERR press MAN CLEAR to terminate procedure and bypass present position update.

Do step 8 or 9:

8. UPDATE switch - Press.
Automatically updates present position.
9. MAN CLEAR switch - Press.
Bypasses updating of present position.

TRACK LEG UPDATE

MODE switch in ASTRO INERTIAL, INERTIAL ONLY, DEAD RECKON, or AIR START position; MODE window displays any mode.

1. DATA switch - DEST POINT or NORMAL.
2. Enter point - ID code (five digits) of start DP on desired track leg. Last four entered digits appear in SD-6 window, (first digit, always zero, replaces letter P with D).
3. UPDATE switch - Press.

DIRECT STEER

In any "operate" mode:

1. DATA switch - DEST POINT or NORMAL.

For direct steer to tape-filled or panel-filled DP:

2. Enter five digit ID code of DP in memory (tape-filled or panel-filled). Last four entered digits appear in SD-6 window.

3. DIR STEER switch - Press.

For direct steer to new DP:

4. Enter latitude of new DP in degrees (two digits), minutes (two digits), and hundredths (two digits). Entered data appears in SD-1 window.

5. Enter longitude of new DP in degrees (three digits) minutes (two digits), and hundredths (two digits). Entered data appears in SD-4 window.

6. DIR STEER switch - Press.

The ANS automatically proceeds to the next great-circle leg if Direct Steer DP is in memory. The ANS commands a constant 35

SECTION IV

degree, right wing down turn upon passing a new Direct Steer DP, or a DP with no next leg.

SKIP TO DP

In any "operate" mode:

1. DATA switch - DEST POINT or NORMAL.
2. Enter five digit ID code of DP to be skipped to. Last four digits appear in SD-6 window.
3. SKIP TO switch - Press.

DELETE FP, CP, AND DP
(40-LIST)/CLEAR 40 LIST

This procedure permits deleting points from the 40-List (panel-filled Add/Replace points). After a point is deleted the vacated space may be reused. In any "operate" mode:

Do steps 1, 2, & 4 for single point deletion. Do steps 1, 3, & 4 to clear entire 40-list.

1. DATA switch - DEST POINT, FIX POINT, CONT PT.
2. Enter ID code (five digits) of FP, CP or DP to be deleted. All digits appear in SD-6 window.
3. ID CODE 99999 - Enter.
4. DELETE switch - Press.

ADD ANYTIME FIXPOINT

Normally, this procedure is followed closely by a Present Position Update procedure, using the Radar or Viewsight. It can only be used on the existing leg, as no ID code is established for the Anytime Fixpoint.

In any "operate" mode:

1. DATA switch - FIX POINT.
2. Fixpoint Latitude - Enter (N/S XX°XX.XX').

Entered data appears in the SD-1 window.

NOTE

If any of the sensor operation indicator lights are illuminated, they extinguish when N or S is pressed. The automatic sensors continue to operate normally during the add Anytime Fixpoint routine. The SLR light illuminates if an add Anytime radar fix is displayed after all data is entered (After step 6). None of the sensor operation indicator lights illuminate if an add anytime viewsight fix is displayed.

3. Fixpoint Longitude - Enter (E/W XXX°XX.XX').

Entered data appears in SD-4 window.

4. Fixpoint Elevation - Enter (XXX).

Enter the terrain elevation of the fixpoint in hundreds of feet (three digits). For example, 12,500 feet is entered as 125. Entered data appears in the SD-3 window.

For Radar Fixpoint, do steps 5 and 6: for Viewsight Fixpoint, skip to step 6.

5. SLR code - Enter near edge range (L/R XX.0).

Last entry must be zero. Entered data appears in SD-5 window.

6. ENTER switch - Press.

NOTE

The DATA switch may now be used to display other than fixpoint data. If returned to FIXPOINT and ENTER before the fixpoint, anytime fixpoint data will be retained and displayed. The fix may be taken with the DATA switch in NORMAL. The viewsight or radar opportunity fix must still be taken on the leg during which it was entered. Existing FPs will be inhibited until the Anytime FP is passed.

ADD OR REPLACE FP, CP, DP**NOTE**

- o For DP's perform steps 1 through 4, then 9 and 10.
- o For CP's, perform steps 1 through 5, then 6, 7, 8 and 10.
- o For FP's, perform steps 1 through 5, and 10. Also do step 6 for radar FP's.

In any "operate" mode:

1. DATA switch - DEST POINT, FIX POINT, or CONT PT.
2. Enter ID code (five digits) of FP, CP, or DP to be added or replaced. All entered digits appear in SD-6 window.

NOTE

- o 0XXXX Point No. displays DXXXX, FXXXX, or CXXXX, 1XXXX Point No. displays F1XXXX or C1XXXX. Only zero allowed for first digit of DP.
- o If a FP is added to be used immediately (Add-Anytime FP) do not enter an ID code number. All other FPs in memory will be inhibited until the added FP is passed.

3. Enter N or S and latitude of added or replaced point in degrees (two digits), minutes (two digits), and hundredths minutes (two digits). Entered data appears in SD-1 window.
4. Enter E or W and longitude of added or replaced point in degrees (three digits), minutes (two digits), and hundredths minutes (two digits). Entered data appears in SD-4 window.

Skip to step 9 if entered point is a DP; continue with step 5 if point is CP or FP.

5. Enter terrain elevation of FP or CP in hundreds of feet (three digits). Entered data appears in SD-3 window.

Skip to step 10 for viewsight FPs. Perform step 6 for radar FPs and CPs or step 7 for camera CPs.

6. SLR code - Enter near edge Range (L/R XX.0).

Last entry must be zero. Entered data appears in SD-5 window.

7. Press RIGHT or LEFT pushbutton and enter camera CP code (L/R plus 000). Entered data appears in SD-5 window.

Skip to step 10 for radar FP's.

8. For all CPs enter sensors on-off code (three digits). First entered digit is LH TECH camera, second is RH TECH camera, and third digit is SLR. Enter 0 for off at CP, and 1 for on at CP. Corresponding sensor operation indicators illuminate to indicate sensor selection for the CP.

If a Fixed-Range-To-Turn is desired:

9. Enter turn radius of added or replaced DP in nm (three digits). Entered data appears in SD-3 window.
10. ENTER switch - Press.

SECTION IV

NORMAL DISPLAY

In any "operate" mode:

1. DATA switch - NORMAL.
2. DISPLAY switch - Press.
 - a. SD-1 window displays letter Z and GMT in hours (two digits), minutes (two digits), and seconds (two digits).
 - b. SD-2 window displays letter T and true airspeed in knots (XXXX).
 - c. SD-3 window displays letter F or F1 and next FP (four digits).
 - d. SD-4 window displays R or L and cross track error in nautical miles (XXX.X).
 - e. SD-5 window displays letter G and ground speed in knots (XXXX).
 - f. SD-6 window displays letter C or C1 and next CP number (four digits).
 - g. Sensor indication lights illuminate when the associated sensor is programmed on.
- b. SD-2 window displays letter R and slant range to selected point if TACAN, great circle range to CP or FP, or great circle range to DP.
- c. SD-3 window displays letter E and terrain elevation of selected FP or CP. For DP, letter K and turn radius is displayed (255 nm max).
- d. SD-4 window displays longitude of selected point.
- e. SD-5 window displays L or R and relative bearing (four digits) to a selected CP or DP; or letter B and magnetic bearing in degrees (four digits), to TACAN FP.
- f. SD-6 window displays data code of selected point.
- g. L/R TECH and SLR lights illuminate to indicate sensor activity at selected FP or CP. The SLR light is not illuminated during display of viewsight fixpoints.

DISPLAY SELECTED FP, CP, DP

In any "operate" mode:

1. DATA switch - DEST POINT, FIX POINT, or CONT PT.
2. Enter ID code (five digits) of desired FP, CP, or DP.

SD-6 window displays all entered digits (except first digit).
3. DISPLAY switch - Press.
 - a. SD-1 window displays latitude of selected point.

DISPLAY NEXT FP, CP, DP

MODE switch in ASTRO-INERTIAL, INERTIAL ONLY, DEAD RECKON, or AIR START position; MODE window displays any mode.

1. DATA switch - DEST POINT, FIX POINT, or CONT PT.
2. DISPLAY switch - Press.
 - a. SD-1 window displays latitude of next FP, CP, or DP.
 - b. SD-2 window displays letter R and slant range to TACAN FP, along track range for radar or viewsight FP or CP and along track range to turn start point (TSP) for DP (which includes the computed range around a closed loop turn).

- c. SD-3 window displays letter E and terrain elevation of next FP or CP, in hundreds of feet. For DP, letter K and turn radius is displayed (255 NM max).
- d. SD-4 window displays longitude of next FP, CP, or DP.
- e. SD-5 window displays L or R and relative bearing in degrees (four digits) to next viewsight or radar FP, CP, DP, or letter B and magnetic bearing in degrees (four digits) to next TACAN FP.
- f. SD-6 window displays data code of next FP, CP, or DP.
- g. L/R TECH and SLR lights illuminate to indicate sensor activity at next FP or CP. The SLR light is not illuminated during display of view-sight fixpoints.

NOTE

- If there is no next FP or CP on the current leg, SD-2 window displays zero range and other displayed data will be for the preceding FP or CP. If there was no preceding FP or CP, all SELECTED DATA windows except 5 display all zeros. The SD-5 window displays bearing to zero latitude and longitude coordinates.
- If DATA switch is in DEST POINT and LOOK THRU switch is pressed:
 - 1) SD-1 window displays latitude of DP after next DP.
 - 2) SD-2 window displays range to DP after next DP.

- 3) SD-3 window displays turn radius of DP after next DP.
- 4) SD-4 window displays longitude of DP after next DP.
- 5) SD-5 window displays time to DP after next DP (four digits) in minutes and tenths.
- 6) SD-6 window displays the DP number after next DP. If no DP exists after next DP, SD-6 window displays D0000 and all other SELECTED DATA windows are blank.

DISPLAY DAY OF YEAR/STAR DATA

In any "operate" mode:

1. DATA switch - TIME.
2. DISPLAY switch - Press.
 - a. SD-1 window displays letter Z and GMT in hr., min, sec.
 - b. SD-2 window displays letter S and star number.
 - c. SD-3 window displays the scan rate code of the star-tracking telescope (R1, R2, R3 or R4).
 - d. SD-4 window displays letter T and time in star search in min. and sec.
 - e. SD-5 window displays letter A and number of stars acquired.
 - f. SD-6 window displays letter D and Julian date.

SECTION IV

NOTE

Julian day Display changes after 2400 GMT and may read any value from 0 to 511. Day values greater than 365 allow next calendar year usage of the star catalog in the computer.

DISPLAY HEADING

In any "operate mode":

1. DATA switch - HEADING.
2. DISPLAY switch - Press.
 - a. SD-1 window displays letter V and ground track in degrees (three digits), minutes (two digits), and tenths of minutes (one digit).
 - b. SD-2 window displays letter G and computed grid heading in degrees and tenths of degrees (four digits).
 - c. SD-3 window displays letter C and the chart convergence factor (four digits) (1.000 max).
 - d. SD-4 window displays letter T and true heading in degrees (three digits), minutes (two digits), and tenths of minutes (one digit).

NOTE

Displayed true heading is ANS inertial data except that INS data is used in dead-reckon mode and in ground and cold airstart coarse alignments until a heading update is performed.

- e. SD-5 window displays E/W magnetic variation (four digits).
- f. SD-6 window displays letter M and magnetic heading (three digits).

DISPLAY PRESENT POSITION

MODE switch: ASTRO INERTIAL, INERTIAL ONLY, DEAD RECKON, or AIR START; MODE window displays any mode.

1. DATA switch - PRES POSITION.
2. DISPLAY switch - Press.
 - a. SD-1 window displays N or S latitude of alternate frame in degrees (two digits), minutes (two digits), and hundredths of minutes (two digits).
 - b. SD-2 window is blank.
 - c. SD-3 window displays letter A and ANS altitude (three digits) (flight level).
 - d. SD-4 window displays E or W longitude of alternate frame in degrees (three digits), minutes (two digits), and hundredths of minutes (two digits).
 - e. SD-5 window displays letter S and sun angle in degrees and tenths (three digits).
 - f. SD-6 window is blank.

PRESENT DISPLAY

- A. PRESENT LATITUDE window displays present N/S latitude in degrees and minutes (four digits).
- B. PRESENT LONGITUDE window displays present E/W longitude in degrees and minutes (five digits).

NOTE

Window displays are blank until completion of F/A, at which time primary coordinates are displayed depending on MODE switch position.

- C. WIND DIR window displays present wind direction in degrees (three digits). While on the ground with ANS operating but not calculating, and if wind direction is not filled, the WIND DIR counter displays 000.
- D. WIND VEL window displays present wind velocity in knots (three digits). While on the ground with ANS operating but not calculating, the WIND VEL counter displays 0.
- E. TIME-TO-TURN window displays the time to turn in hours, minutes, and seconds (five digits). The TIME-TO-TURN window displays 0 until the aircraft moves.
- F. RANGE TO DP (NM) window displays the range to the next destination point, shown in the NEXT DP window (four digits). Until the present position has been filled, the RANGE TO DP (NM) window will be blank.
- G. NEXT DP window displays the next destination point identification number (four digits). The first (left) digit is blank if the DP is not an added point, or the actual ADD NUMBER (1 thru 7) if the DP is an added point. Until present position has been filled, the NEXT DP window will be blank.
- c. SD-3 window displays letter G and general instrument constants tape number (three digits).
- d. SD-4 window is blank.
- e. SD-5 window displays letter S and star catalog type as follows:
 SYY1 - Normal (worldwide)
 SYY2 - Trainer
 Where YY=last two digits of the year.
- f. SD-6 window displays letter T (test) and 0.

ANS MALFUNCTION PROCEDURES

The ANS provides warning indications of some malfunctions or conditions external to the ANS that could lead to an ANS malfunction. All malfunctions are not detected, so the crew should not depend entirely on warning indications.

Temperature Limit/Tolerance Indicator

The LIMIT portion of the indicator is unlighted when temperatures within the ANS are normal. The red LIMIT can illuminate either steady or flashing. A steady light indicates that the temperature of the astro-inertial instrument housing or the cooling air at the computer inlet is above nominal limits. Steady illumination after initial turn-on is caused by system over-temperature. A flashing light indicates that ANS cooling airflow is less than 2.5 pounds per minute. To prevent damage, turn the ANS off when the temperature LIMIT indicator comes on.

When the LIMIT light illuminates, the RSO's annunciator panel ANS FAIL light, and the pilot's annunciator panel ANS REF caution light illuminate.

When the TEMP TOLR light is unlighted, the platform temperature is in the range for optimum system performance. The amber TOLR light illuminates either steady or flashing. Steady illumination signifies that

DISPLAY TAPE NUMBERS

In any "operate" mode:

- 1. DATA switch - TEST.
- 2. DISPLAY switch - Press.
 - a. SD-1 window displays letter I and main program tape number, (six digits) representing tape number, mod number, and correction number.
 - b. SD-2 window displays * or A thru Z or a thru e and mission tape number (three digits).

SECTION IV

platform temperature is below normal. A flashing light signifies that temperature is above normal.

Figure 4-18 lists ANS temperature warning indications, conditions and recommended actions.

TEMP LIMIT Light Illuminates

1. Check ECS system.

If L or R air system failed:

- a. Complete L or R Air System Out procedure.

If L or R air system off for landing:

- b. Check cockpit air off (forward).

If TEMP LIMIT light remains illuminated:

- ▲ 2. ATT REF switch - INS.
- T 3. DISPLAY MODE SEL switch - Other than ANS.
- ④ 4. BDHI HDG SELECT switch - INS.
- ⑤ 5. MODE switch - OFF.

CAUTION

If the TEMP LIMIT light cannot be extinguished, turn the MODE switch OFF to avoid damage to the ANS.

TEMP TOLR Light Illuminates in Flight

Make as many position checks as practical since navigation accuracy may degrade in a TEMP TOLR condition. Be alert for a possible TEMP LIMIT light.

NOTE

If the TEMP TOLR light illuminates in flight, do not turn the ANS off unless the TEMP LIMIT light illuminates.

Malfunction Indicator (MAL Light)

The MODE window usually indicates action to be taken when the MAL light is flashing. Several of the conditions for a MAL light are synonymous with conditions for nav-not-ready indications described under the Warning Indication section. Figure 4-19 lists general ANS malfunction and nav-not-ready conditions.

NOTE

When the MAL light illuminates, the RSO's annunciator panel ANS FAIL light, and the pilot's annunciator panel ANS REF caution light illuminate.

Power Dropout

A decrease of the ANS ac supply voltage to less than 103 volts per phase causes the computer to stop operating regardless of mode. Voltage drop can be caused by a primary power transient, opening of the ANS 3-phase essential ac or essential dc circuit breaker(s), or turning the MODE switch to OFF or WARM UP. When power returns, the computer determines power dropout duration by comparing chronometer day and time with the day and time stored in memory at power loss.

If the power dropout is less than one second, operation resumes as though nothing occurred except star tracking is suspended for 70-seconds.

If the power dropout is greater than one second, the system returns to C/A, the MAL light illuminates, the MODE window indicates C/A, and all display counters clear. If the RSO presses the HOT switch, the system proceeds with an automatic restart (hot airstart or ground hot start). If, instead, the RSO selects AIRSTART with the MODE switch and presses the MODE START switch, the system starts a COLD airstart. Refer to COLD Airstart Alignment, this section.

(Note: 4-60A/4-60B Blank deleted)

ANS TEMPERATURE WARNINGS

INDICATOR	STATE	ANS CONDITION	ACTION
Red TEMP LIMIT Light	Off	Within safe limits	_____
	Steady	Air inlet housing or cooling air at computer inlet above design limits.	Turn MODE switch OFF.
	Flashing	Cooling air flow less than 2.5 lb/min.	Turn MODE switch OFF.
Amber TEMP TOLR Light	Off	Within tolerance for optimum accuracy	_____
	Steady	Platform temp below normal.	Check ANS accuracy
	Flashing	Platform temp above normal	Be alert for TEMP LIMIT. Check ANS accuracy. Keep rpm up if warning on due to hot fuel in flight.

Figure 4-18

NOTE

If the system is HOT started and then a COLD airstart is desired, return the MODE switch to OFF. If the MODE START switch is pressed in any MODE other than AIRSTART, the system must be turned off to initiate a COLD airstart.

NOTE

After a power dropout, pressing MODE START on the ground with the MAL light flashing (initiating a ground alignment) erases the 40-List. Anytime a rapid or a gyro-compass ground alignment is performed, 40-List data must be reentered. 40-List data is not deleted if HOT is pressed with the MAL light flashing or if a cold or hot airstart is performed. Therefore, 40-List data is retained for a ground hot start, cold airstart, or a hot airstart. Pressing the MODE START switch with a steady MAL light has no effect on the 40-List.

SECTION IV

Flashing MAL Light During Ground Operation

It is normal for the MAL light to flash when the MODE switch is moved from OFF or WARM UP to ALIGN, ASTRO INERTIAL, or INERTIAL ONLY. The MODE window reads C/A if the system has a DAY and TIME, or I/O if a DAY and TIME are not available from the chronometer. The MAL light will go out after DAY and TIME are filled, MODE START is pressed and MAN CLEAR is pressed.

If the MAL light flashes during any ground operation after either MODE START or RAPID is pressed to start an alignment, observe the MODE window and SELECTED DATA (SD) windows.

1. If the MODE window display has not changed and the SD windows are frozen, a computer malfunction has occurred. Turn the MODE switch to OFF and restart the alignment. If the malfunction repeats, replace the ANS guidance group.
2. If the MODE window has changed to C/A and the SD windows are cleared, a power dropout in excess of 1 second has occurred. If a GROUND HOT START is desired, complete the GROUND HOT START checklist. If a GROUND HOT START is not desired, turn the MODE switch to OFF and perform another ground alignment.
3. If the mode window has changed to ENC and the SD true heading is in question, the yaw encoding has malfunctioned. "Synthesized heading" (true ground track output to the HSI and BDHI compass cards and NCD panel) cannot be accurately calculated when not moving. Pressing MAN clear extinguishes the flashing MAL light and removes the ENC indication but does not remove the

malfunction. Replace the ANS guidance group. Refer to YAW Encoding Failure this section.

4. If the MODE window has changed to I/O and the SD windows are not affected, the platform collimator light (artificial star) has not been tracked. This is most likely due to the platform collimator bulb being burned out. Otherwise it is a tracker malfunction. This malfunction only occurs at the end of C/A or ENT. If the ANS guidance group cannot be replaced, press the MAN CLEAR switch to extinguish the MAL light. The MODE window will initialize normally. Attempt to track stars in ASTRO INERTIAL. If stars cannot be tracked, fly in INERTIAL ONLY.
5. If the MODE window has changed to I/O and the SD windows are cleared, a power dropout with no DAY and/or TIME available from the chronometer is indicated. This would also happen if no chronometer were available. Turn the MODE switch to OFF, replace the chronometer, and perform another alignment. If a chronometer is not available:
 - a. If a correct DAY and TIME are available, insure MODE switch is set to desired type alignment, fill day and time, press MODE START or RAPID and continue with GROUND ALIGNMENT checklist.
 - b. If correct DAY and TIME are not available insure MODE switch is set to desired type alignment, and press MODE START or RAPID. If RAPID was selected, then turn the MODE switch to INERTIAL ONLY and MODE START. This extinguishes the flashing MAL light and a RAPID alignment will continue. Perform the Ground Alignment Correct procedure if desired.

NOTE

The first MODE START or RAPID start selects the type alignment. But INERTIAL ONLY has to be MODE started to clear the flashing MAL Light if DAY and/or TIME are not available, either from the chronometer or fill routine.

- 6. If the MODE window has changed to D/R, a platform failure or platform disable is indicated. Confirm by pressing MAN CLEAR switch while observing the MODE window and the MAL Light.
 - a. If the MODE window then changes to A-I or I/O, and the MAL light goes off, a platform failure is indicated. The SD windows will not be affected. If the ANS guidance group can be replaced, turn the MODE switch to OFF, replace the group and realign. If the group cannot be replaced, select DEAD RECKON with the MODE switch, and complete DEAD RECKON MODE checklist.

NOTE

The MODE window change and MAL light extinguishing could be momentary. The light will go out when the window reverts to A-I or I/O. The window may eventually revert back to D/R with a flashing MAL light.

- b. If the MODE window remains D/R and the MAL light goes out, a platform disable is indicated. The counters will be referenced to the DEAD RECKON frame. Select DEAD RECKON with the MODE switch and press MODE START. Then select ASTRO INERTIAL or INERTIAL ONLY and press MODE START again. The NAV-READY functions will now resume and the system will operate normally.

Flashing MAL Light In Flight

It is normal for the MAL light to flash when the MODE switch is moved from OFF or WARMUP to ASTRO INERTIAL, INERTIAL ONLY, or AIR START. The MODE window will read C/A if the system has a day and time or I/O if a day and time are not available from the chronometer. The MAL light will go out after DAY and TIME are filled, MODE START is pressed and MAN CLEAR is pressed.

If the MAL light flashes during airborne operation, observe the MODE window and SELECTED DATA windows.

- 1. If the MODE window display has not changed and the SD windows are frozen, a computer malfunction has occurred. Turn the MODE switch to OFF and attempt a COLD AIRSTART.
- 2. If the MODE window has changed to C/A and the SD windows are cleared, a power dropout in excess of 1 second has occurred. Attempt a HOT AIRSTART procedure. Otherwise press MAN CLEAR, select DEAD RECKON with the MODE switch, and complete DEAD RECKON mode checklist. A COLD AIRSTART may then be performed. The COLD AIRSTART is also necessary if the HOT AIRSTART is unsuccessful.
- 3. If the mode window has changed to ENC and the SD windows are not affected, the yaw encoding has malfunctioned. "Synthesized heading" (true ground track) is output to the HSI and BDHI compass cards and NCD panel as true heading. Pressing MAN clear extinguishes the flashing MAL light and removes the ENC indication but does not remove the malfunction. Refer to Yaw Encoding Failure this section.
- 4. If the MODE window has changed to I/O and the SD windows are cleared, a power dropout with no day and/or time avail-

SECTION IV

able from the chronometer is indicated. Turn the MODE switch OFF and perform a COLD AIRSTART. If DEAD RECKON mode is preferable to a COLD AIRSTART, press MAN CLEAR to initialize the system. Select INERTIAL ONLY and MODE START to extinguish the flashing MAL Light. Then select DEAD RECKON and complete the DEAD RECKON checklist.

NOTE

The initial position error will probably be very large due to no time reference when the system is initialized after pressing MAN CLEAR. Fill present position or update by fixing.

5. If the MODE window has changed to D/R, a platform failure or platform disable is indicated. Confirm by pressing the MAN CLEAR switch, while observing the MODE window and the MAL light.
 - a. If the MODE window then changes to A-I or I/O and the MAL light goes off, a platform failure is indicated. To confirm platform failure, check ANS attitude, heading, and ground-speed displays. The SD displays will not be affected. Turn the MODE switch to DEAD RECKON and complete the DEAD RECKON mode checklist, or turn the MODE switch to OFF and attempt a COLD AIRSTART.

NOTE

The MODE window change and MAL light extinguishing may be momentary in the event of a platform failure. The light will go out when the MODE window reverts to A-I or I/O. But the window will eventually revert back to D/R and the MAL light will flash again.

- b. If the MODE window remains D/R and the MAL light goes out, a platform disable is indicated. The SD displays will be referenced to the DEAD RECKON frame. Select DEAD RECKON with the MODE switch and press MODE START. Then select either ASTRO INERTIAL or INERTIAL ONLY with the MODE switch and press MODE START again. The NAV-READY functions will now resume and the system will operate normally.

All NCD Panel Windows Blank

If all NCD panel lights and windows go blank it indicates loss of ac or dc power to the ANS. Check the ANS essential dc and ANS 3 phase ac circuit breakers and the position of the MODE switch. When power is restored, as indicated by the MAL light flashing, follow the procedures listed under Flashing MAL Light During Ground Operation or Flashing MAL Light In Flight.

INERTIAL NAVIGATION SYSTEM (INS)

The SKN-2417 INS is the source of inertially derived magnetic reference for the basic flight instruments and radio navigation aids. It also provides aircraft attitude and navigation information. The INS consists of the inertial navigation unit (INU), the inertial control panel (ICP) and the INU battery.

The system provides present position, ground-speed and steering, distance, and enroute time to 10 destinations and 3 mark points. Destination points may be entered or changed any time the system has power applied and are retained in the computer memory after power is removed. Mark points are entered in memory by a panel routine which allows sequential and repetitive marking of present position in the 3 mark points A, B and C.

Heading information is furnished to the:

1. DAFICS for autopilot, PVD heading input, and SAS analytical redundancy (ANR) when the pilot's attitude reference select switch is in INS.

NOTE

The auto-nav feature of the autopilot is disengaged and cannot be used when INS is selected.

2. Pilot's HSI.
3. BDHI when the BDHI heading select switch is in INS.

Attitude information is furnished to the:

1. Autopilot when the pilot's attitude reference select switch is in INS.
2. ADI when the pilot's attitude reference select switch is in INS.
3. Peripheral Vision Display (PVD) when the pilot's attitude reference switch is in INS.
4. Attitude Indicator when the RSO's attitude indicator select switch is in INS.

NOTE

Heading information is not provided in either alignment mode. The INS must be in the NAV mode before a valid heading display is available on the compass cards. With a computer failure, which causes the system to revert to the attitude mode (ATT), or with the FUNCTION switch set to ATT, the RSO controls compass card orientation with the heading slew knob.

INS OPERATION

The INS is programmed with global magnetic variation to 78 degrees north latitude and 65

degrees south latitude. During the NAV mode of operation the INS does not have an enterable grid navigation capability. A free gyro capability is available with the INS operating in the ATT mode with the limitation that once this mode is selected all computer and navigation functions are terminated leaving only attitude and heading available for the remainder of the flight. In the ATT mode the HSI and BDHI heading must be set using the heading slew knob.

The NAV mode cannot be reentered from the ATT mode. The INS does not have an air alignment function to restore full navigation capability.

ANS grid mode navigation should not be used since there is no useable grid heading display available to either cockpit in NAV mode and the ANS dead reckon (DR) frame does not receive correct heading information to maintain accurate navigation.

Waypoint to waypoint navigation with the INS, as with the ANS, is via great circle steering. With either system apparent heading change on a given leg is not obvious at lower latitudes, whereas at higher latitudes large apparent heading change is evident.

When in the NAV mode and within the latitude limits, (between 78N and 65S) the INS operates in the automatic mag var mode (MODE SEL light off). This will allow magnetic headings to be flown and maintains correct TACAN relative bearing. The pilot's standby compass can be used to cross-check heading. When crossing the automatic mag var latitude limit of the INS (steering toward a pole) the mag var is maintained at the last computed value until recrossing the latitude limit (steering toward the equator).

If zero MAG VAR is manually set when north of 78 degrees North latitude or south of 65 degrees South latitude (MODE SEL light on), the INS provides a true heading readout to the compass cards, which can be cross

SECTION IV

INERTIAL CONTROL PANEL (ICP)

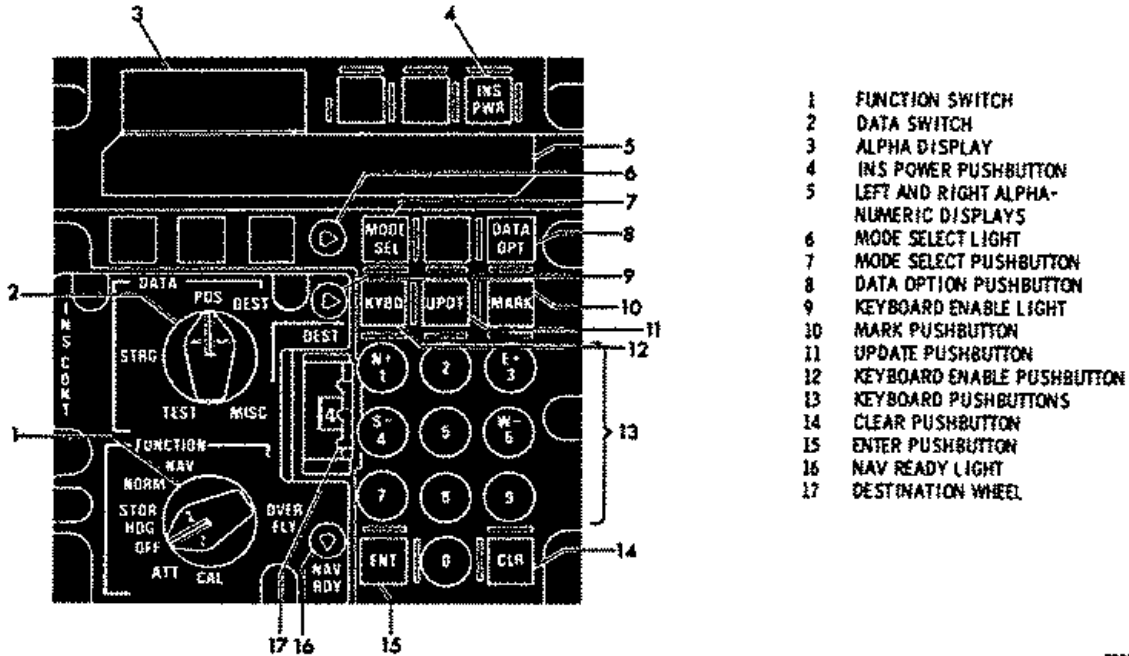

Figure 4-20

F203-289(w)

checked with the ANS. In this case the magnetic bearing to a TACAN station will be correctly displayed but the relative bearing will be in error.

INERTIAL CONTROL PANEL (ICP)

The ICP (Figure 4-20) is on the aft cockpit left console.

FUNCTION Switch

Selects the INS operating modes. The switch must be pushed down to rotate into or out of positions OFF, STOR HDG, NORM and ATT; it cannot be rotated directly from OFF to ATT or from ATT to OFF.

OFF INS operation is disabled.

STOR HDG Selects quick reaction alignment if aircraft has not moved since last alignment.

NORM Selects normal alignment.

NAV Selects inertial navigation.

OVERFLY Selects inertial navigation and allows overfly update.

CAL A ground maintenance function used to recalibrate INS gyros.



ATT Selects inertial attitude and heading without navigation or computer correction for apparent precession.

The INS remains in inertial navigation at all switch positions between NAV and ATT.

DATA Switch

Used in conjunction with the DATA OPT pushbutton to establish what data is called

INERTIAL CONTROL PANEL DATA DISPLAYS

DATA SWITCH	DATA OPT PUSHBUTTON	ALPHA DISPLAY	LEFT DISPLAY	RIGHT DISPLAY
POS		L/L	Present Position latitude (to nearest tenth of an arc minute).	Present Position longitude (to nearest tenth of an arc minute).
	First press	V/T	Groundspeed (to nearest knot).	Aircraft true ground track (to nearest tenth of a degree).
	Second press	H/M	True heading (to nearest tenth of a degree).	Computed or manually entered mag var (to nearest tenth of a degree) 
	Third press	IS	Time in alignment (to nearest tenth of a minute).	Alignment status (50, 40, 30, etc.).
DEST		L/L	Latitude of DP on DEST wheel (to nearest tenth of an arc minute).	Longitude of DP on DEST wheel (to nearest tenth of an arc minute).
	First press	E/T	BLANK	Time to DP on DEST wheel (hours) and minutes). (Groundspeed more than 75 knots).
	Second press	D/C	Distance to DP on DEST wheel (to nearest nautical mile).	Computed true ground track to DP on DEST wheel from Present Position (to nearest tenth of a degree).
STRG		G/C	Distance to DP on DEST wheel (to nearest nautical mile).	Time to DP on DEST wheel (hours) and minutes). (Groundspeed more than 75 knots).
	First press	MDC 	0	0
TEST		INS 	O, FAIL 1 or FAIL 2	Failure indication.
	First press	PNL	O	O
	Second press		Blank	Blank
MISC	The MISC position is used to display and/or enter various INS parameters. Of primary interest to the operator (RSOI) is the entry of altitude into the system at various points in the mission in order to prevent degradation of system navigation performance. Refer to Altitude Update.			

 With MODE SEL light on, computed mag var is removed from HSI and BDHI, heading displayed on instruments is true heading plus or minus manually entered mag var. If E or W "O" mag var is displayed then heading displayed on instruments is true heading.

 No meaningful data is presented with this display option selected.

 If Fail 1 or Fail 2 appears refer to INS Fault Indication Clearing.

Figure 4-21

F203-291

SECTION IV

from the computer for display, or what data may be keyed for entry into the computer. Refer to Figure 4-21 for data options.

ALPHA Display

Provides a three character label identifying the information being displayed in the left and right data displays, or the information to be entered into the system.

INS PWR Pushbutton

Pushbutton switch used in conjunction with the FUNCTION switch to turn the INS on or off. When aircraft power is removed, the DNU battery will discharge unless the INS PWR switch is off.

Left and Right Data Displays

The left and right alphanumeric data displays display readouts or show values keyed for entry.

MODE SEL Pushbutton

Used in conjunction with the DATA selector switch to enable automatically computed or manually entered magnetic variation. It is used to initiate self test (TEST position of the DATA switch) during the first 2 minutes of a normal (NORM) alignment. It is also used to clear INS fault indications.

MODE SEL Light

The light illuminates when manual magnetic variation is selected. It illuminates during a maintenance self-test and extinguishes after 5 minutes when the test is complete.

DATA OPT Pushbutton

Used in conjunction with the DATA switch to select the displays available at each DATA switch position. See Figure 4-21.

MARK Pushbutton

Enters present position into computer memory for recall as a point of interest. After 3

sequential MARK points have been accomplished (A, B and C) subsequent marking erases the previous point(s) in order (A, B, C).

UPDT Pushbutton

Used when the FUNCTION switch is in OVERFLY to update INS present position.

KYBD Pushbutton

Enables or disenables the keyboard buttons.

Keyboard Light

The light is on when the keyboard is enabled and off when keyboard is disenabled.

Keyboard Pushbuttons

When enabled, used to select codes and numerical data for display and entry.

CLR Pushbutton

Used to clear the displays if an error is made during keyboard inputs.

ENT Pushbutton

Used to enter data into the computer upon completion and validation of keyboard inputs.

NAV RDY Light

The light illuminates steady at the completion of fast alignment; the light flashes at the completion of full alignment. The light goes out when the FUNCTION switch is set to NAV.

DEST Wheel

Used to select destinations (0 - 9) for computer entry via the keyboard and to select the desired destination or mark point (A, B or C) to steer to. The mark point selected for display by the DEST wheel cannot be changed by the marking routine when it is being displayed. Mark points D, E and F are not used.

Heading Slew Knob

A heading slew knob is on the RSO's instrument panel adjacent to the BDHI switches. The knob sets HSI and BDHI heading if the INS enters ATT mode (either automatically by computer failure or selected by the RSO). The best known heading reference should be set.

INS Segment Lights Control

A light control labeled INS SEG LTS on the left aft console varies the intensity of the INS segment lights (Alpha, left and right data displays). The light control is powered by the emergency ac bus through the INS PRIME circuit breaker on the pilot's right console.

INS Panel Lights

INS panel lighting is controlled by the L CONSOLE light control.

INU Battery

A self-contained battery on the INU mount provides continued INS operation for up to 10 seconds in the event of aircraft or ground power transients. The battery charges when the FUNCTION switch is not OFF and the INS PWR switch is ON.

NOTE

Continued INS operation after loss of power discharges the INU Battery.

INS PROCEDURESNormal Alignment

Normal alignment (NORM) is a gyrocompass alignment which requires only correct present position and is completed in less than 8 minutes at temperatures above 40°F. For temperature less than 40°F the alignment time will be increased to 9 minutes at 0°F and 12 minutes at -40°F. Six minutes into the alignment, fast ready is indicated by

steady illumination of the NAV RDY light. The NAV RDY lamp flashes at the completion of alignment.

A fast ready capability is available from normal alignment by selecting NAV mode with the FUNCTION switch after steady illumination of the NAV RDY light. Attitude information and navigation capability are available, however, navigation accuracy will be degraded.

With the DATA switch in POS, the third press of the DATA OPT pushbutton will allow inertial alignment status (IS) to be monitored. Prior to fast ready (NAV RDY steady light at six minutes) the status indicates "99" (course alignment in progress) or "90" (fine alignment in progress). After fast ready (NAV RDY light steady) and before ready (NAV RDY light flashing) inertial status (IS) decreases in units of 10 (60, 50, 40, 30, 20) to indicate improving CEP (error probable) as alignment improves. When "10" is displayed, specification performance is available, the NAV RDY light flashes, and alignment is complete; however INS accuracy may improve beyond specification requirements if alignment is continued in NORM. During self test, the align status indicates "80" from 4 to 6 minutes in self test.

1. INS PWR pushbutton - Press.
2. FUNCTION switch - NORM.
3. DATA switch - POS, alpha display is L/L.

If left and right data displays indicate correct position continue to step 4, otherwise perform the following:

- a. KYBD pushbutton - Press, keyboard light on.
- b. Enter latitude - N or S XX°XX.X'
- c. ENT pushbutton - Press. Check latitude in left display.

SECTION IV

- d. Enter longitude - E or W
XXX°XX.X'
 - e. ENT pushbutton - Press. Check longitude in right display.
4. DATA OPT pushbutton - Press three times, alpha display is IS (Inertial Status). Right display counts down from 99 to 10 indicating alignment status. Left display counts up indicating time in alignment.

NOTE

Other ICP activity, such as entry or verification of destination coordinates or altitude entry may be accomplished during alignment. Entry of system latitude or heading will reinitialize alignment.

- 5. DATA switch - MISC, enter field elevation.
 - a. KYBD pushbutton - Press, keyboard light on.
 - b. Altitude address - Enter 1138.
 - c. CLR pushbutton - Press
 - d. +(3) keyboard pushbutton - Press.
 - e. Enter field elevation - XX,XXX ft.
 - f. ENT pushbutton - Press. Check altitude in right display.
 - g. DATA switch - POS.

When NAV RDY light flashes:

- 6. FUNCTION switch - NAV.

NAV RDY light illuminates steady after 6 minutes. Select NAV mode if fast ready (minimum time) alignment is required.

NOTE

Setting the FUNCTION switch to NAV from STOR HDG, NORM or CAL prior to steady illumination of the NAV RDY light will transfer the INS to the ATT mode and alignment must be reinitialized.

At 8 minutes, NAV RDY light flashes indicating full alignment is complete.

NOTE

- o The FUNCTION switch must be in NAV prior to taxiing the aircraft, or realignment will be required.
- o When the NAV mode is selected after alignment the INS remains in the navigate mode until the FUNCTION switch is set to OFF or ATT, or a computer failure occurs. There is no capability to reenter an alignment mode after the NAV mode has been selected. If short delays occur before takeoff maintain the INS in the NAV mode. For prolonged delays it may be desirable to turn the INS off and perform another alignment.
- o The FUNCTION switch must remain off for 2 minutes before reinitiating alignment to optimize system accuracy during the new alignment.

Stored Heading Alignment

The stored heading alignment provides a quick reaction capability and can only be accomplished if the aircraft has not been moved after previous INS shutdown. Stored heading (STOR HDG) alignment is normally completed in less than 4 minutes at temperatures above 60°F. For temperature less than 60°F, the alignment time increases to 5 minutes at 0°F and 6 minutes at -40°F.

When the absolute minimum alignment is completed, (about one minute above 25° and 2 minutes at -40°F) fast ready (steady NAV RDY light) is indicated with a fine alignment in process status ("90"). At alignment complete (NAV RDY flashing) status "30" is displayed. This occurs at 1-1/2 minutes above 40°F. The status is then decremented (30 to 29 to 28, etc.) every fifteen seconds until status "20" is displayed.

1. INS PWR pushbutton - Press.
2. FUNCTION switch - STOR HDG.

If the aircraft has not been moved since the last INS shutdown, skip to step 3, otherwise perform the following:

- a. DATA switch - POS, alpha display is L/L. Check present latitude and longitude in left and right displays.
- b. DATA OPT pushbutton - Press twice, alpha display is H/M. Check magnetic variation in right display.
- c. DATA switch - STRG, alpha display is G/C.
- d. DATA OPT pushbutton - Press, alpha display is HDG.
- e. KYBD pushbutton - Press, keyboard light on.
- f. "1" keyboard pushbutton - Press, left display blanks.
- g. Enter true heading - XXX.X°
- h. ENT pushbutton - Press. Check heading in left display.

When NAV RDY light flashes:

3. FUNCTION switch - NAV.

NOTE

Minimum fine alignment is complete in 1-1/2 minutes (NAV RDY light flashing and status IS 30). Specification performance is not available until status IS 20 appears (2-1/2 minutes after NAV RDY light flashing).

Airborne Attitude Alignment

Should the INS fail completely in flight, it may be possible to reestablish the platform in the attitude (ATT) mode. This will not provide navigation capability, but will provide pitch, roll and heading to the cockpit displays. The RSO can use the heading slew knob to establish a heading reference.

1. FUNCTION switch - OFF.

Flags will appear on the attitude instruments with INS attitude source selected.

After 2 minutes:

2. FUNCTION switch - ATT.
3. Maintain straight and level flight.

At the end of the 36 second coarse alignment phase, the flags will disappear from the attitude instruments. INS pitch and roll attitude displays are now available. The INS heading display will be the platform azimuth angle.

After 36 seconds and OFF Flags out of view:

4. Heading Slew Knob - Set desired heading.
5. Monitor INS pitch and roll displays.

When the point reaches the intersection of the viewsight groundtrack reference line and nadir depress the INS UPDT pushbutton.

1. DATA switch - DEST.
2. DEST wheel - Set DP (0-9).
3. Enter latitude - N or S XX °XX.X'.
Enter latitude of point to be used for position update.
4. ENT pushbutton - Press. Check latitude in left display.
5. Enter longitude - E or W XXX °XX.X'.
Enter longitude of point to be used for position update.
6. ENT pushbutton - Press. Check longitude in right display.
7. FUNCTION switch - OVERFLY.
8. UPDT pushbutton - Depress when point is reached.
9. FUNCTION switch - NAV.

Marking Procedure

Any point overflowed may be "marked" for subsequent use or reference. Depressing the MARK pushbutton will cause MKA, MKB or MKC to appear in the Alpha display. The left and right displays continue to display present position. After 10 seconds the Alpha display returns to normal operation. The marked point can then be displayed by setting the destination wheel to A, B, or C and the DATA switch to DEST. The system will maintain three points at any time. Repetitive marking erases the previously marked points in order.

DATA Displays

Data is displayed using the DATA switch and DATA OPT pushbutton. Repositioning the DATA switch selects the first display of that position. Remaining displays for a given

DATA switch position are selected by depressing the DATA OPT pushbutton. See Figure 4-21 for data displays available.

Attitude Mode (ATT)

In ATT mode the INS operates as an inertial attitude and heading reference platform. The ATT mode is entered automatically in the event of computer failure or may be selected by the operator.

The ATT mode is entered by rotating the FUNCTION switch clockwise and pressing before reaching the ATT position. The INS remains in ATT mode until the FUNCTION switch is OFF.

NOTE

NAV mode cannot be reentered from the ATT mode. Once ATT mode is entered all INS navigation capability is lost.

Failure Indications

The INS REF caution light on the pilot's annunciator panel is illuminated by a computer failure or heading failure (INS automatically in ATT mode), FUNCTION switch in ATT mode, or platform failure.

If the pilot's attitude reference select switch is in INS and the INS is in ATT mode (automatically or by setting the FUNCTION switch in ATT) a course warning flag appears on the pilot's ADI to indicate heading is not reliable. When the INS is operating in ATT mode, DAFICS analytical redundancy, autopilot operation, and PVD operation are not affected.

If the pilot's attitude reference select switch is in INS and the INS platform fails (attitude malfunction), an OFF flag appears on the pilot's ADI in addition to the course warning flag. A DAFICS analytical redundancy failure is indicated (flashing red DAFICS PREFLIGHT BIT FAIL light), the autopilot will not engage, and PVD operation is inhibited. If the RSO selects INS attitude reference the RSO's attitude indicator displays an OFF flag.

SECTION IV

INS "NO WARNING" MALFUNCTIONS

DISPLAY		MALFUNCTION	EFFECT
LEFT	RIGHT		
FAIL 1	000002	BITE ON BITE	NO INTERNAL TEST
FAIL 1	000100	VERTICAL VELOCITY	GRADUAL NAV DEGRADATION
FAIL 1	000200	REDUNDANT LOOP	GRADUAL NAV DEGRADATION
FAIL 2	002000	INU BATTERY FAILED	NO AIRCRAFT POWER LOSS PROTECTION
FAIL 2	004000	MUX 1	ERRONEOUS, BLANK OR FROZEN DISPLAYS
FAIL 2	010000	MUX 1	
FAIL 2	020000	MUX 2	

Figure 4-22

Therefore, if the pilot is using the ANS as the attitude source and the INS REF annunciator light illuminates, the RSO should check the aft cockpit attitude indicator (INS attitude reference). If the power OFF flag is not in view the INS is operating in ATT; if the power OFF flag is in view there is an INS platform (attitude) malfunction.

An INS malfunction that illuminates the INS REF annunciator caution light can be considered a hard failure. There is a remote possibility of clearing a malfunction inflight by attempting the INS Fault Indication Clearing Procedure. There are seven additional malfunctions that could occur which do not illuminate the INS REF light. Two cause degraded accuracy, three cause erroneous, blank or frozen ICP displays, and the remaining two do not affect system performance. None of the seven are evident through the aircraft warning system, but they can be viewed on the ICP with the DATA switch set to TEST. See Figure 4-21.

INS Fault Indication Clearing Procedure

1. DATA switch - TEST, Alpha display reads INS.
 - a. If Left and Right displays read "O" - No action required.

- b. If Left display reads FAIL 1 or FAIL 2 (Figure 4-22) - Perform steps 2 through 4.
2. DATA OPT - Press twice, Alpha display reads CLR.
3. MODE SEL - Press, MODE SEL light ON.
4. DATA OPT - Press, Alpha display reads INS, MODE SEL light OFF. If FAIL 1 or FAIL 2 reoccurs, notify maintenance.

Attitude Outputs

Failures of INS attitude output servos could cause frozen attitude displays (including inputs to DAFICS), rapidly changing attitude values, or gradually increasing attitude errors. This is particularly dangerous at night or in IFR conditions, especially if the pilot's attitude reference select switch is in INS and the auto pilot is engaged. An ANR light (flashing DAFICS PREFLIGHT red FAIL light) could indicate that the selected attitude reference is erroneous. Monitor other attitude references (ANS platform and pilot's standby attitude indicator) to detect INS attitude errors as soon as possible.

SENSOR SYSTEMS

The following sensor systems are available:

1. Two high-resolution, narrow field technical objective cameras (TECH).
2. Advanced Synthetic Aperture Radar System (ASARS).
3. High resolution, side-looking radar (SLR) for mapping (CAPRE).
4. ELINT Improvement Program/Electromagnetic Reconnaissance (EIP).
5. Optical bar camera (OBC).

The following equipment complements the sensor systems:

1. V/H system.
2. Viewsight.
3. Map projectors (two). (Refer to Section I).
4. Exposure control system.
5. Mission Recorder System (MRS).

SENSOR COMPARISON CHART.

	TECHNICAL CAMERA	ASARS	CAPRE	EIP	OBC	
V/H RANGE	21-45				35-45	
STABILIZATION AND LIMITS	NOT STABILIZED	PITCH ROLL YAW TILT	PITCH ROLL YAW TILT	NOT STABILIZED	NOT STABILIZED	
FAIL LIGHTS	CONNECTED TO SENSOR FAIL	CONNECTED TO SENSOR FAIL	CONNECTED TO SENSOR FAIL	CONNECTED TO SENSOR FAIL	CONNECTED TO SENSOR FAIL	
IMAGE MOTION COMPENSATION	MIRROR ROTATION AND EXPOSURE RATE				HOODING FMC	
OPERATION	MANUAL OR AUTOMATIC	MANUAL OR AUTOMATIC	MANUAL OR AUTOMATIC	MANUAL	MANUAL	
FILM TAPE CAPACITY	FILM 9-1/2 x 9-1/2 IN.	TAPE 9200 FT (2)	FILM - 1300 FT	TAPE (2)	5" FILM	
WARMUP TIME	20-40 SEC	6 MIN	6 MIN	2 MIN	PRELIGHT	
POWER TURN	ON	AFTER TAKEOFF	AFTER TAKEOFF	AFTER TAKEOFF	AFTER TAKEOFF	AFTER ENGINE START
	OFF	PRIOR TO LANDING	PRIOR TO LANDING	PRIOR TO LANDING	PRIOR TO LANDING	AFTER LANDING

F203-103(1)(X-)

Figure 4-23

SECTION IV

SENSOR COMPONENT AND DEF EQUIPMENT LOCATIONS

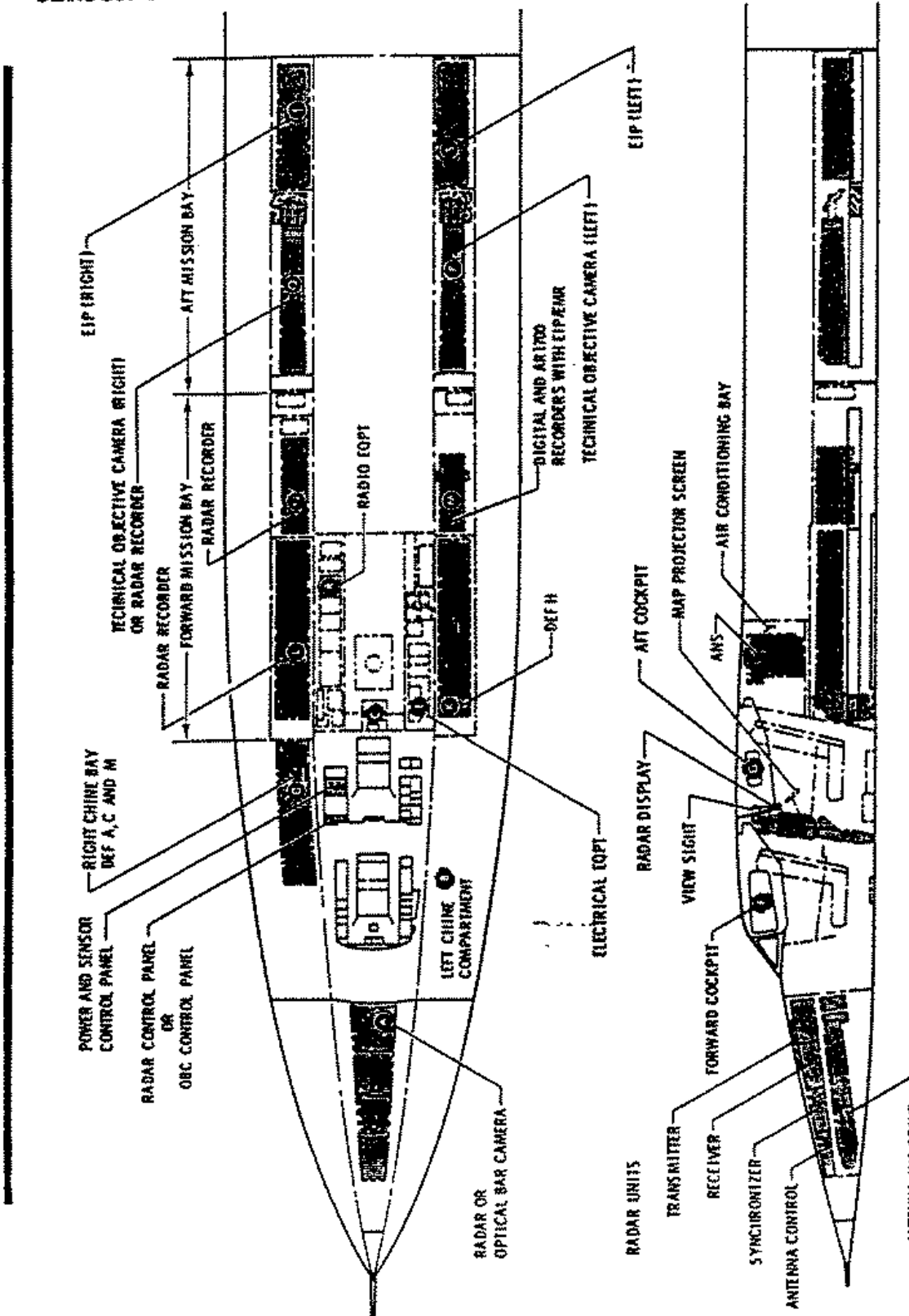

NOTE
 The terms "MISSION EQUIPMENT BAY" and "CHINE BAY" are synonymous and interchangeable

● • Compartment designation

Figure 4-24

F250-476a)

POWER AND SENSOR CONTROL PANEL

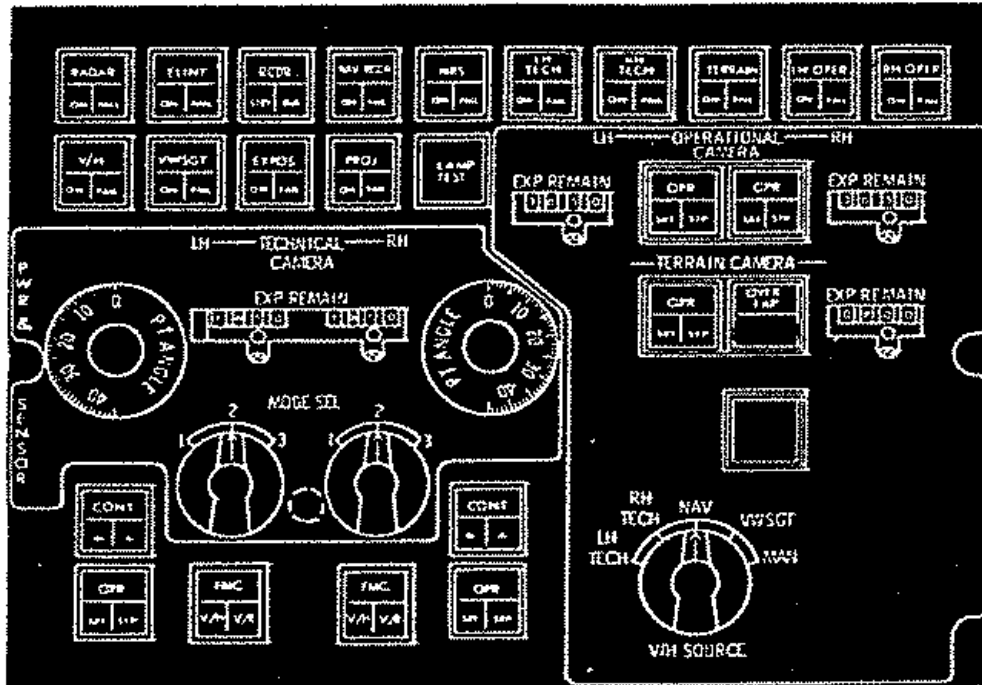

F202-3110

Figure 4-25

POWER AND SENSOR CONTROL PANEL

The power and sensor control panel, labeled PWR & SENSOR, is on the RSO's right console. It contains power switches for all of the sensors, and the control switches for the cameras and the V/H system. For information concerning switch operation, refer to the individual sensor description(s).

The Terrain Objective Camera System (TROC) and Operational Objective Camera System (OOC) are no longer available. The seven alternate action switches and three film counters (on the upper right portion of the panel) that were associated with these systems are no longer used.

NOTE

- Application or reapplication of electrical power to the aircraft electrical system while a sensor power switch is ON requires the sensor power switch to be cycled OFF and then ON to reapply power to the sensor.
- Set each sensor operation switch to STP or STBY before moving its power switch to OFF.

TECHNICAL OBJECTIVE CAMERA SYSTEM (TECH)

Two TECH cameras mounted in the left and right aft mission equipment bays, are used for obtaining detailed photographic imagery. These cameras are often referred to as TEOC cameras. TEOC and TECH are synonymous. They are variable pointing angle, high-resolution, narrow field cameras that produce overlapping exposures of the terrain below or

SECTION IV

to the side of the flight path. The cameras are either automatically controlled by the ANS, or manually controlled by the RSO. Camera controls are on the power and sensor control panel. The lateral pointing angle of each camera is read on an indicator on the left side of the RSO's instrument panel. The exposure-remaining counters, failure indication, and pointing-angle indicator are used to monitor camera operation.

There are two camera models; the HR-308B and the HR-308C. There are two versions of the HR-308B, the -11 and the -21. The HR-308B is unstabilized (except for passive vibration isolation) while the HR-308C is actively stabilized in pitch, roll, and, at higher look angles, yaw. Another difference is the source of forward motion compensation (FMC), although FMC is mechanized similarly in all cameras by rocking the oblique mirror in the camera head at a variable rate determined by V/R (velocity divided by slant range).

Camera field of view (FOV) is [REDACTED]. Each camera may be pointed laterally [REDACTED] degrees (aircraft nadir) [REDACTED] outboard on its side of the aircraft. The stabilized look angle is the sum of the aircraft bank angle and camera pointing angle, thus with the aircraft [REDACTED] bank the look angle could vary from [REDACTED] degrees. Terrain coverage in a single frame from operational altitude typically varies from a [REDACTED] square [REDACTED] look angle to a [REDACTED] area with the center of the field of view approximately [REDACTED].

The cameras are normally operated automatically by depressing the CONT A pushbutton on the PWR & SENSOR control panel, selecting NAV V/H source, and setting the FMC to V/R.

NOTE

FMC for the -11 HR-308B must be set to V/H during turns where that camera is the upwing camera.

Should manual camera operation be required, the RSO must set the mode and pointing

angle controls to prebriefed settings. The cameras are switched to manual mode by depressing the CONT pushbutton on the PWR & SENSOR control panel to illuminate the M legend. The NAV V/H source may still be used if the ANS is in operation, but for manual operation the FMC setting will depend upon the model and version of the camera in use. The -11 HR-308B and HR-308C require the same FMC setting and will provide the same FMC accuracy in manual or automatic operation. For -21 HR-308B manual operation, FMC should be set to V/H, which provides accurate FMC in level flight only (image degradation can be expected in turns).

The pointing angle and overlap coverage for the different manual modes of camera operation vary with the model and version of the camera in use.

Mode Selector

Two rotary mode selector (MODE SEL) switches on the PWR & SENSOR control panel, one for each camera, select the desired mode during manual operation. The switch is effective only when the respective CONT switch illuminates M and has three operating mode positions, labeled 1, 2, or 3:

MODE 1 (all):

Single exposures at 1.1 per second at the selected pointing angle.

MODE 2

-11 HR-308B:

Single exposures at a V/R controlled rate which provides [REDACTED] overlap between successive exposures at the selected pointing angle.

-21 HR-308B and HR-308C:

Single exposures every 1.25 seconds alternating between 4 degrees greater and 4 degrees less than the selected pointing angle.

MODE 3 (all):

Single exposures at a V/R controlled rate which provides [REDACTED] overlap between successive exposures alternating between 4 degrees greater and 4 degrees less than the selected pointing angle.

TECH Camera Power Switches

A self-illuminated pushbutton power switch for each camera is located on the forward edge of the PWR & SENSOR control panel. The switches are labeled LH TECH and RH TECH. Operation of either switch illuminates ON and applies power to the camera but does not initiate operation. (Camera temperature control circuitry is not controlled by this switch.) The FAIL portion of the switch illuminates to indicate a malfunction within the respective camera and the camera will be simultaneously deactivated. The SENSOR FAIL annunciator and RSO master CAUTION lights illuminate when the FAIL portion of either switch illuminates.

TECH Camera Mode Control Switch

A self-illuminated pushbutton-switch, labeled CONT, M, A, is located on the lower left of the PWR & SENSOR control panel.

The CONT portion of the switch illuminates when the tech camera power switches illuminate ON. The lower left quarter of each switch is labeled M (manual) and the lower right quarter is labeled A (automatic). The A and M portions illuminate alternately when the control switch is pressed. When the A portion is illuminated, the camera is controlled by the ANS. When the M portion is illuminated the OPR switch, MODE SEL switch, and PT ANGLE switches control the cameras.

TECH Camera Operate Switches

A self-illuminated camera operate pushbutton switch, labeled OPR in the top half, is provided for each camera. The lower left quarter of the switch is labeled SRT (start) and the lower right quarter STP (stop); SRT and STP illuminate alternately as the pushbutton is pressed. The switch is effective only when its related control switch is in manual (M) position. The OPR portion of the

switch illuminates immediately for the -21 HR-308B and HR-308C, or in approximately 30 seconds for the -11 HR-308B after the power switch is actuated to ON. Either version of HR-308B camera can operate as soon as power is on with no image degradation. Due to stabilization delay the HR-308C should not be operated until 15 seconds after OPR illuminates. If the CONT switch is in M (manual), verify that the OPR switch is in STP until camera operation is desired.

FMC Selector Switch

Self-illuminated FMC selector pushbutton switches, one for each camera, select the signal source for forward motion compensation. The top half of the pushbutton is labeled FMC and the legend illuminates when its respective camera power switch is on. The lower left quarter of the switch is labeled V/H and the lower right quarter is labeled V/R. The V/H and V/R legends illuminate alternately when the pushbutton is actuated. When the V/R legend illuminates, the camera is using the primary source of FMC input. When the V/H legend illuminates, the camera is using an alternate source of FMC input. The signals selected as primary and alternate sources are:

-11 HR-308B Normal Operation:

- a. FMC switch - V/R; V/H source switch - NAV.

This is used for straight and level flight.

When V/R is selected, the Bus V/H is fed into and modified in the camera for head position only.

- b. FMC switch - V/H; V/H source switch - NAV.

V/H is used for the upwing camera during operation in turns with bank angles of 30 or 45 degrees.

SECTION IV

When V/H is selected, the Bus V/H is fed into and modified in the camera head for mirror position and a preset bank angle of 30° or 45°. This preset bank angle is set in the camera and cannot be changed by the RSO.

NOTE

In both cases (above), camera uses Bus V/H so if NAV V/H source fails the RSO must switch to VWSGT or MAN source.

-21 HR-308B Normal Operation:

- a. FMC switch - V/R; V/H source switch - NAV.

This setting is used for straight and level or turning flight.

When FMC - V/R is selected, NAV V/R, which takes into account aircraft bank angle and commanded pointing angle, is fed directly to the camera IMC and Film Drive circuits.

If NAV V/R fails:

- b. FMC switch - V/H; V/H source switch - NAV.

When FMC - V/H is selected, the V/H bus is fed to and modified in the camera head by mirror position only and does not take into account aircraft bank angle. It can be used in straight and level flight only.

If NAV V/H source fails:

- b. Set V/H source switch to VWSGT or MAN.

ER-308C Normal Operation:

- a. FMC switch - V/R; V/H source switch - NAV.

When FMC - V/R is selected, the voltage on the bus is fed to the camera where it is modified by the aircraft bank angle, camera head mirror position and camera roll position. This modified signal is then fed to the IMC and Film Drive circuits.

If NAV V/H source fails:

- b. Set source switch to VWSGT or MAN.

If Bus fails in all positions:

- c. FMC switch - V/H.

When FMC-V/H is selected, NAV V/R voltage is fed directly to the IMC and Film Drive circuits. (NAV V/R takes aircraft bank angle and commanded pointing angle into account but not actual camera head mirror position or camera roll position.)

Image degradation as a result of using V/H in lieu of V/R can be slight to moderate depending on the stability of the aircraft.

Pointing Angle Selectors

Rotary PT ANGLE controls, on the PWR & SENSOR control panel, one for each camera, position the camera pointing angle during manual operation. The pointing range extends from zero to 45 degrees from aircraft vertical. The control is effective only when the respective CONT switch illuminates M.

Exposures Remaining Counters

Four-digit EXP REMAIN counters, on the PWR & SENSOR control panel indicate exposures remaining for each camera. When the camera is freshly loaded each counter indicates [REDACTED] exposures. Camera cycling decreases the respective counter.

NOTE

There is a remote possibility that the counter(s) may stick and not drive. Assume normal automatic camera operation if the respective sensor light on the ANS NCD panel illuminates, pointing angle and V/H (V/R) indicators appear reasonable, and the respective FAIL light is not illuminated.

Camera Pointing Angle Indicator

A circular CAMERA PT ANGLE indicator is on the RSO's left instrument panel. The indicator has two pointers (L, R) indicating respective camera pointing angle from 0 to 45 degrees, left and right of the aircraft vertical axis. In the manual mode, the indicator is a repeater for the pointing angle controls on the PWR & SENSOR control panel and indicates the manually selected angle. In the automatic mode, the indicator displays ANS pointing commands to the cameras.

TECH NORMAL PROCEDURES

For automatic camera operation:

1. LH(RH) TECH power switch -ON.
2. Mode control (CONT) switch - A.
3. FMC selector switch - As required.

For manual camera operation:

1. LH(RH) TECH power switch -ON.
2. Mode control (CONT) switch -M.
3. OPR switch - STP.
4. FMC Selector switch - As required.
5. MODE SEL switch - As briefed (1, 2, or 3).
6. PT ANGLE control knob - As briefed.

7. OPR switch - SRT/STP as briefed when appropriate.

TECH MALFUNCTION PROCEDURES

For EXP REMAIN counter not decreasing in AUTO continue normal operation if:

- a. TECH L and/or R sensor light is on.
- b. Pointing angle indicator responds to control point commands.
- c. FMC is valid.
- d. FAIL indicator and SENSOR FAIL lights are not on.

NOTE

A TECH camera FAIL indication may result from a camera malfunction or from a loss of V/H (V/R) signal input. Only the latter case can be corrected by the RSO.

If the FAIL indicator is on use the following procedure to determine if the FAIL is due to a camera malfunction or a V/H (V/R) failure:

1. Mode Control (CONT) switch - M.
2. OPR switch - STP.
3. MODE SEL switch - Mode 3.
4. V/H - Check.

With V/H SOURCE selector switch in NAV and V/H MONITOR switch in BUS, check that the A needle on the V/H indicator indicates correctly. If indication appears accurate go to step 9.

If NAV V/H appears inaccurate:

5. V/H - Select an alternate V/H source.

If alternate V/H source appears accurate:

6. OPR switch - SRT.

SECTION IV

NOTE

Loss of V/H signal to the -11 HR-308B or loss of both V/H and V/R signals to the -21 HR-308B or HR-308C makes camera inoperative in Mode 3. Manual operation in Modes 1 or 2, with grossly degraded FMC is possible in 20 second bursts. The FAIL indicator illuminates and the OPR switch must be cycled to STP then SRT every 20 seconds.

7. EXP REMAIN counter - Note normal operation for 30 seconds.

If FAIL does not illuminate, Automatic or Manual operation is available.

If FAIL illuminates (for -21 HR-308B camera):

8. OPR switch - STP.
 9. FMC switch - Set alternate signal if using -21 HR-308B camera.
 10. OPR switch - SRT.
 11. EXP REMAIN counter - Note normal operation for 30 seconds.

If FAIL does not illuminate Automatic or Manual operation is available.

If FAIL illuminates:

12. OPR switch - STP.
 13. TECH power switch - OFF.

SIDE-LOOKING RADAR (CAPRE) SYSTEM

The CAPRE System is a side-looking synthetic aperture radar. When installed, it replaces the Optical Bar Camera System. The Radar Correlator Display (RCD) can be operated with the CAPRE SLR System to produce an in-flight display for navigation. However, the main function of the SLR is to expose a film strip which records reflected

radar signals. Range marks and data block information are automatically superimposed on the film. The radar can cover a strip 10 or 20 nm wide, on either side of the aircraft with the near edge of the swath between 10 and 70 nm from the aircraft. The CAPRE can only image during non-turning flight. The ANS provides automatic stabilization to allow operation during limited drift angles. Mapping information received by the antenna in the aircraft nose section is recorded on film on two recorders in the aft portion of the right forward mission bay.

Automatic and manual operating modes are provided. In the automatic mode, system operation is controlled by the ANS. In the manual mode, the RSO controls operation.

Except for the power switch on the PWR & SENSOR control panel, controls and indicator lights for the SLR are located on the radar control panel on the RSO's right console. A display of radar altitude is also provided by a digital indication on the radar control panel. Power for the SLR is furnished by the essential ac and monitored dc buses through circuit breakers in the C-bay.

Radar Power Control Switch

The self-illuminated radar pushbutton power switch has a white illuminated RADAR legend in the top half and is located on the PWR & SENSOR control panel. The ON portion of the pushbutton alternately illuminates and extinguishes as the pushbutton is depressed. The FAIL portion of the pushbutton illuminates when the SLR fails self-test. Illumination of the FAIL light illuminates the SENSOR FAIL light on the RSO annunciator panel. Removing RADAR power or a successful SLR self-test extinguishes the FAIL light.

RADAR CONTROL PANEL

The radar control panel on the RSO's right console controls the SLR. See Figure 4-26.

CAPRE SLR CONTROL PANEL

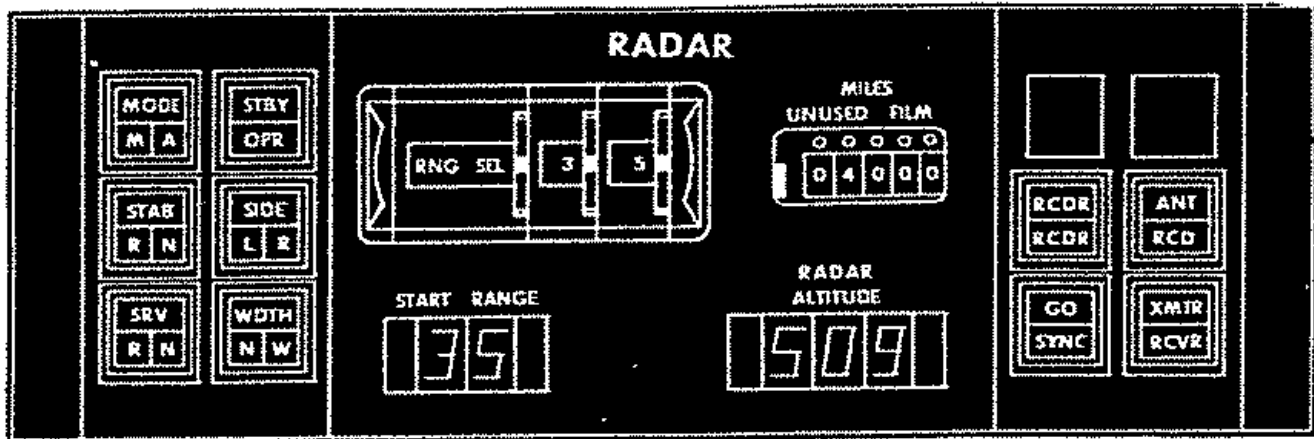

F203-178(a)

Figure 4-26

Mode Selector Switch

A self-illuminated mode selector pushbutton switch displays an illuminated MODE legend in the top half when power is applied to the radar. The bottom half of the switch has two legends, A (automatic), and M (manual) which illuminate alternately as the pushbutton is depressed. A indicates automatic SLR operation. M illuminates during manual operation and during normal system shutdown.

Standby-Operate Switch

The self-illuminated standby (STBY)/operate (OPR) pushbutton switch illuminates when the radar system warm-up period is completed (approximately 6 minutes after power has been applied). In the manual mode, the STBY and OPR light illuminate alternately when the pushbutton is depressed. In the automatic mode, the light indicates operate/standby commands received from the ANS.

STAB Selector Switch

Not functional. Stabilization is provided automatically by the ANS at all times.

SIDE Selector Switch

The self-illuminated SIDE selector pushbutton switch illuminates in either the manual or auto mode. The bottom quarters of the pushbutton have legends L (left) and R (right) which alternately illuminate when the push-button is depressed. In automatic mode, the legend indicates the antenna position command received from the ANS.

SRV Selector Switch

Not functional. The slant range velocity signal, utilized for motion compensation, is provided automatically by the ANS at all times.

Width Selector Switch

A radar mapping swath width selector switch is on the left side of the radar control panel. A WIDTH legend is displayed in the top half of the switch. Either N (narrow) or W (wide) appears in the bottom half.

SECTION IV

When start ranges of 20, 35, 40, 50 or 60 miles are selected in a manual mode, a choice of either a 10 or 20 mile swath width may be made by alternately depressing the WIDTH switch to illuminate either N (narrow, 10 mile) or W (wide, 20 mile) coverage. The WIDTH switch is electrically interlocked to illuminate only N for all other start ranges. Better radar image resolution will be obtained in the N position, and should be used unless mission requirements dictate a wider swath coverage. The RCD swath coverage and resolution are unaffected by the WIDTH switch. In the automatic mode, the legend indicates the width command received from the ANS.

Start Range Selector Switches

Two thumb-wheel type start range selector switches, labeled RNG SEL are in the center of the radar control panel. The switches select the ground range at which mapping starts in manual mode. Start ranges of 10 through 70 nautical miles may be selected in five mile increments. (Selection of the ambiguous 75 miles start range is electrically interlocked to provide 70 miles, as indicated on the START RANGE indicator). The RNG SEL legend and the numbers illuminate only when the mode switch is in M.

Start Range Indicator

A start range indicator, labeled START RANGE, is on the left side of the radar control panel. The indicator displays the ground range in nautical miles from nadir to the start of the swath being mapped. The indication should agree with the RNG SEL switch setting during manual mode operation. During automatic mode operation, the indicator indicates the mapping range command received from the ANS.

MILES UNUSED FILM Counter

A MILES UNUSED FILM digital counter shows the nautical miles of film remaining in SLR recorder number one. It has a five-digit range of 0 to 4999. 4000 appears when the adjacent reset button is pressed. The initial indication is preset on the ground and the counter should not be readjusted in flight. Recorder number two has no associated digital counter.

Radar Altitude Indicator

A radar altitude indicator is on the right side of the radar control panel. The indicator displays radar altitude above the terrain when the SLR is operating.

The SLR will not update altitude if there is a difference of more than 5,000 feet between SLR and ANS altitude. If ten consecutive measurements are not valid, the altitude validity signal will be set to not valid. This signal is transmitted to the ANS to prevent ANS altitude update and turns off the SLR altitude display illumination. This also occurs if the SLR is turned off, placed in standby or if there is an SLR failure.

NOTE

The indicator lights could give erroneous readings if the aircraft is overflying heavy cloud concentrations. The indicator will provide normal readings when clear of these areas unless a radar altitude malfunction is present.

BIT Test Indicators

The BIT (Built-In-Test) indicator lights are on the right side of the radar control panel. The BIT is automatically activated approximately six minutes after the SLR is turned on and

remains activated until the SLR is turned off. If the tests are satisfactory, the green GO legend illuminates and remains on. If the radar malfunctions, the faulty radar component (XMTR, RCVR, SYNC, ANT, RCD, RCDR) indicator light(s) illuminate red. There is a possibility of a momentary RCDR or XMTR fail indication during initial turn on or when OPR is selected. This condition should self clear.

NOTE

If any BIT indicator lights illuminate, the SENSOR FAIL light and RADAR power switch FAIL light also illuminate.

SLR NORMAL OPERATION

CAUTION

The radar power switch must not be ON when the airplane is on the ground unless cooling air is supplied.

For automatic mode operation:

1. RADAR power switch - ON.
2. MODE switch - A.

For manual mode operation:

1. RADAR power switch - ON.
2. MODE switch - M.
3. SIDE switch - As required.
4. START RANGE switch - As required.
5. WIDTH switch - As required.
6. STBY/OPR switch - OPR, when required.

SLR MALFUNCTION PROCEDURES

The annunciator panel SENSOR FAIL light and the FAIL light on the power and sensor

control panel illuminate for any failure. If no BIT malfunction is indicated and the FAIL lights remain illuminated, SLR operation is permissible.

If a BIT light illuminates:

XMTR - If the XMTR light is cycling on and off, shut the radar off using the normal shutdown procedure. If the light remains on steady, the system can still be used and operation with or without an RCD picture should be continued.

CAUTION

Failure to turn the radar off when the XMTR light is cycling on and off can damage the radar transmitter.

RCVR - SLR operation is permissible. If a malfunction exists, it may clear later.

ANT - SLR operation is permissible. Malfunction may be due to "G" forces.

RCD - SLR operation is permissible. Recycle RCD power switch. RCD use is doubtful if RCD BIT fail light stays on. RCD fail does not affect recorded signal.

SYNC - SLR operation is permissible.

RCDR - SLR operation is permissible. If the film counter is not moving, use of recorder(s) is doubtful. RCD may be used. Note RCDR number for maintenance information.

NOTE

The top portion of this dual RCDR light reflects RCDR number one and the bottom RCDR number two when two recorders are loaded.

For normal shutdown (during straight and level flight):

SECTION IV

1. Mode switch - M.
2. STBY/OPR switch - STBY.

After 30 seconds:

3. RADAR power switch - ON extinguished.

For emergency shutdown:

1. RADAR power switch - ON extinguished.

RECORDER CORRELATOR DISPLAY (RCD)

The RCD is a self-contained unit in the forward portion of the aft cockpit. It operates in conjunction with, but is independent of the radar recorder(s). The RCD operates when RCD power is applied and only when the SLR is in operation since it uses SLR doppler phase history video to produce an inflight display for navigation. The display moves downward at a rate proportional to ground speed and is normally 50 seconds (25 nautical miles at cruise speed and altitude) behind aircraft position. The RCD map display is 15 nautical miles wide. This display must be stopped for target evaluation and navigation fixpoint error determination.

RCD Control Panel

The RCD control panel (figure 4-27) is below and to the right of the radar map display. At the left of the panel is a crosshair control. In the center are error readout position counters. There are six display indicator and control switches on the right side of the panel.

Crosshair Control

The CROSSHAIR control moves in all directions but is spring-loaded to return to the center neutral position. When the control is moved from the neutral position, the crosshairs on the radar map display move in the direction of control movement at a rate proportional to the displacement.

Slant-Range Error Readout

A three-digit counter, labeled SLANT RANGE - NMI, indicates lateral error to the nearest one-tenth nm between predicted ANS fixpoint location, as indicated by the illuminated "L" marker on the radar display, and the actual location of the fix on the radar. An adjacent indicator displays LEFT or RIGHT to indicate direction of crosshair displacement from the ANS computed position. Although the maximum counter indication is 99.9 nautical miles, the system will only display an error up to 15 nm.

Along-Track Error Readout

A three-digit ALONG TRACK - NMI counter indicates distance to the nearest one-tenth nm along track between predicted fixpoint location, as indicated by the "L" marker on the radar display, and actual fixpoint location on the radar. An adjacent indicator shows the direction of crosshair displacement, FWD or AFT, from the ANS computed position. The maximum error displayed is 12 nm, although the counters go up to 99.9 nm.

Read Error Control Switch (READ ERR)

This pushbutton switch transmits position error information from the RCD to the ANS. Depressing the switch during tape-filled Radar fixing causes the error data, generated by the position of the crosshairs on the RCD radar display, to appear in SELECTED DATA windows one and four on the ANS NCD panel. The error is displayed as N/S and E/W components in nautical miles and tenths of nautical miles. The READ ERR legend illuminates when the SLR begins manual or automatic operation.

Map Storage Control Switch

This pushbutton switch labeled HOLD/FULL is disabled.

RCD Power Switch

The RCD pushbutton power switch is labeled PWR in the top half, OFF and ON in the bottom half. The switch should be left in the

ON position if operation of the RCD is desired. The OFF position is used only for emergency removal of RCD power or recycling the RCD in specific RCD BIT-Light malfunctions.

Crosshair Readout Zero Control Switch

The crosshair readout zero control pushbutton switch, labeled ZERO in the top and WAIT in the lower half, electrically zeros the crosshair position on the radar display during position error determination. The ZERO legend illuminates when the SLR begins manual or automatic operation. Depressing the pushbutton when the RCD crosshairs are positioned over the intersection of the horizontal and vertical traces of the "L" on the radar display provides an electrical zero reference point for subsequent crosshair movement. WAIT illuminates when the pushbutton is depressed, and stays on for five seconds. This provides time for the SLANT RANGE and ALONG TRACK counters to go to zero. The crosshairs can be positioned on the precise radar fix aimpoint after the WAIT light is off.

Display Motion Control Switch

The display motion control pushbutton switch, labeled MOT (motion) in the top half, R (run) in the lower right quarter, and S (stop) in the lower left quarter, stops the radar map display motion (as required for fix taking) during SLR operation. The legends R and S illuminate alternately as the pushbutton is depressed to start or stop radar map travel. The MOT legend illuminates when the SLR begins manual or automatic operation.

RCD Operate Control Switch

The self-illuminated, operate control pushbutton switch is labeled RCD in the top half, R (run) in the lower right quarter, and S (standby) in the lower left quarter. When power is applied to the SLR with ON illuminated on the RCD power switch, the RCD and S legends illuminate. When the SLR receives a continuous operate command (in automatic or manual mode), the R legend illuminates,

the RCD starts to run, and imagery becomes visible in 50 seconds. While the SLR operate command is present (initiated by either the ANS or the RSO), the switch is functional and may be operated to illuminate S or R. Once the SLR operate command is removed, the RCD goes to the standby status (S illuminated), and operating the switch has no effect. When a radar operate command is removed, the RCD does not immediately stop, but requires approximately 50 seconds for the S legend to illuminate and imagery on the radar screen to cease before going into standby mode.

Video Gain Control

This thumbwheel on the right side of the RCD control panel is disabled.

Film Remaining Counter

A four-digit, decreasing, RCD film remaining counter, labeled N MILES of FILM REMAIN, is located on a small panel to the left of the navigation map projector screen. The counter is preset to 3000 by pushing a reset button above the panel when the RCD film magazine is loaded. It continuously displays the amount of RCD film remaining in nautical miles.

Display Brightness Control

A display brightness control located at the top of the recess provided for the film remaining counter is used to control RCD display brightness.

RCD PROCEDURES

Power to the RCD is controlled by the RADAR power switch and by the RCD PWR switch. With the RCD power switch ON, the RCD and S legends on the RCD Operate Control Switch illuminate when power is applied to the SLR system.

NOTE

The RCD will operate only when the SLR is operating.

SECTION IV

RCD CONTROL PANELS

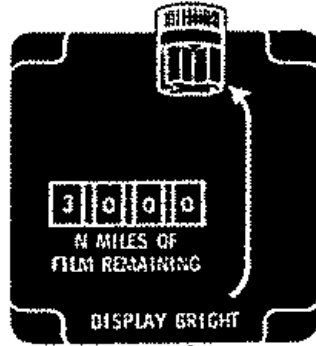

VIEW A
LEFT FORWARD
RCD FILM REMAINING

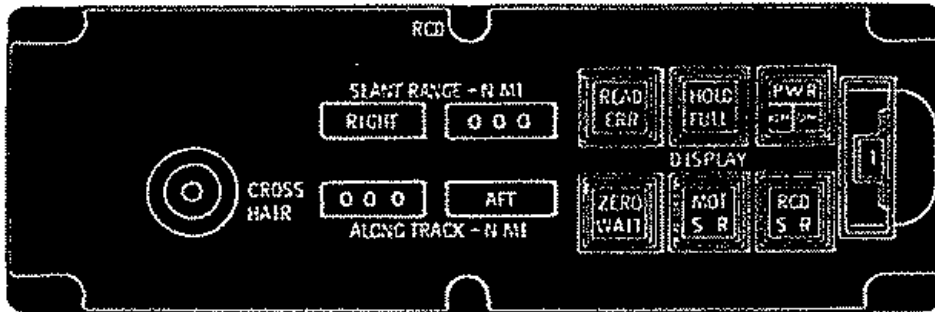
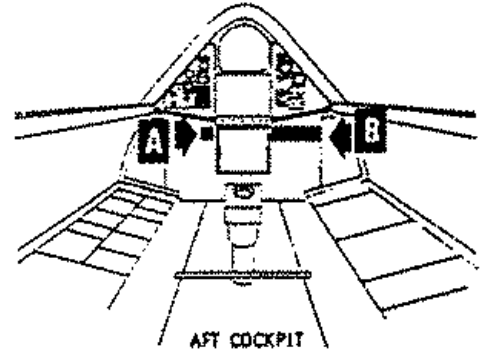

VIEW B
RCD CONTROL PANEL
RIGHT FORWARD
Figure 4-27

F203-234)

1. Radar power control switch - ON.
2. RCD power switch - ON.

To stop display motion:

1. MOT switch - S.

When the SLR is in an operate mode:

3. RCD switch - R
4. MOT switch - R.

If the RCD does not drive and the RCD switch is in R (Run), this switch (MOT) is most likely in S (Stop).

To measure ANS fixpoint error with motion stopped:

1. CROSSHAIR control - Position radar map display crosshairs over the intersection of the horizontal and vertical trace of the ANS "L" marker on radar display.

5. Display brightness - As desired.

NOTE

As the aircraft passes abeam the programmed fixpoint, a MARK light appears at the bottom center of the RCD screen. This alerts the RSO of an impending "L" marker. The MARK light remains illuminated for approximately 50 seconds until the "L"-mark appears on the display. The light goes out when the "L" mark is in the approximate center of the screen.

2. Crosshair readout zero control switch - Depress. WAIT illuminated, then off.

The slant-range and along-track counters on the RCD control panel go to all zeros.

3. CROSSHAIR control - Position radar map display crosshairs over desired fixpoint on radar display.

The values of slant and along-track range errors appear in the respective counters on the RCD control panel.

To transmit measured error data to the ANS;

4. READ ERR pushbutton - READ ERR.
5. MOT switch - R.

OPTICAL BAR CAMERA

The Optical Bar Camera (OBC) is a high resolution panoramic camera with a "folded" lens system. It provides continuous or coverage along the flight track through an angle of 70 degrees on each side of the aircraft.

The camera is mounted on a hatch in an OBC nose. The nose is interchangeable with the SLR nose. Camera controls are on the RSO's right console. Camera temperature is maintained automatically. The film is supported by air through the canopy seal supply line.

The camera is not stabilized, but it has a vibration isolation and damping system which is compatible with its environment in the nose.

An interlock is installed to prevent film damage. Even though the heaters remain energized, the interlock prevents power application to the camera whenever the skew bar and air cage are not receiving air.

CAUTION

The OBC must be off unless both canopies are closed and the canopy seals are on.

The lens system has a fixed relative aperture of . It is mounted on an "optical bar" which accommodates the lens and two mirror assemblies used to create the folded optical path. The optical bar revolves continuously around its longitudinal axis whenever power is applied. Film exposure is accomplished through a scanning slit shutter while the bar and film are in motion. Width of the slit is adjusted automatically to allow for differences in scene brightness and V/H ratio. Full coverage is provided through a scan angle of 140 degrees, with a field angle along the flight path of approximately 8 degrees. Aircraft forward motion compensation is provided during frame exposure when the V/H ratio is between 35 and 45 milliradians (mr) per second; otherwise, the forward motion compensation is automatically set to 40 mr/sec if the applied signal is outside this range.

Image format is nominally inches. A data block in each frame records mission information, frame number, and camera fore and aft or (vertical) orientation.

Cyclic rate of the camera is controlled automatically by the frame overlap requirement of the mode selected, and by V/H forward motion compensation.

SECTION IV

OBC FILM SIZE AND EXPOSURES

Film No.	3414	1414
Thickness	3.0 MIL	1.5 MIL
Width	5 IN.	5 IN.
Maximum Load		
Length		
No. of Exposures		
Standard Load		
Length		
No. of Exposures		
Center Core		
Length		
No. of Exposures		

F203-199 (b)

Figure 4-28

Three operating modes can be selected in flight. Two [REDACTED], which result in [REDACTED] provide either [REDACTED] of successive frames. In the [REDACTED] mode, [REDACTED] is automatic. The nominal convergence angle is twelve degrees (approximately six degrees fore and aft tilt angle) in the [REDACTED] mode.

Control and operating power for the camera is provided from the monitored dc bus. Three phase ac power for the shroud, camera heaters and thermal control system is provided from the essential ac bus. Circuit breakers are located in the C-Bay.

OBC Air Supply and Temperature Control

Camera temperature in flight is controlled automatically by cockpit exhaust air and cold air from the air conditioning system. In addition, electrically operated heaters are provided for the lens system and in the camera shroud.

Air for the skew bar and air cage is obtained from the canopy seal supply line (upstream from the canopy seal control valves) and operates as a cushion to separate the film from the surface of the skew bars where the film path changes direction. Figure 1-71 depicts airflow to the OBC system.

Refrigerated air for the OBC is supplied by an extension of the cold air supply manifold in the forward chine bay. It is normally directed into a shroud above and on each side of the rotating lens system. It then exhausts into the nose compartment. Flow from the supply manifold is filtered and controlled by a barometrically sensitive valve which is open above approximately 45,000 feet. Flow into the lens shroud is also controlled by a diverter valve which opens into the nose compartment and reduces flow to the lens shroud when the camera lens system temperature decreases to a pre-set value. Air supplied from the chine bay manifold is capable of over-cooling the OBC lens system to some extent. This is overcome by electric heaters which maintain the optical bar temperature at approximately 105°F.

Conditioned air exhausted from the cockpit through the nose air shutoff valve is ducted to the top, front, and back of the nose compartment. From the front, it is directed aft to a shroud around the camera hatch windows. A T-bar outlet supplies cool air to the space near the top of the camera electronics compartment and film transport shroud. Air is also directed toward each side of the camera shroud. Another source of cockpit exhaust air is provided by a small sonic venturi. This air is ducted to the camera power transistor locations at each side of the aft end of the camera assembly. These OBC compartment air supply ducts can also be supplied through a ground air connection located under the air exit louvers on the left side of the nose.

CAUTION

- Interruption of cooling air from the chine bay and cockpit while at supersonic cruise speed can damage the camera.
- The OBC must be off unless both canopies are closed and the canopy seals are on.

NOTE

- The camera is normally preheated before nose compartment loading. Warm air is then supplied to maintain the lens system at $105^{\circ}\text{F} \pm 2^{\circ}$.
- Cockpit exhaust air is not available unless both canopies are closed, the RSO's cockpit air shutoff handle is on (aft), and the Bay Air switch is ON.
- Interruption of camera air supplies during the ground stabilization period or during subsonic flight will not damage the camera; however imagery may be degraded.

OPTICAL BAR CAMERA CONTROL PANEL

An optical bar camera control panel, labeled NOSE OBC, replaces the radar control panel on the right console in the aft cockpit. See Figure 4-29.

Power Control Switch & Indicator Light

An alternate action pushbutton POWER switch (guarded) controls ac and dc power to the OBC System, and indicates a failure condition. A white OBC legend is illuminated in the upper half of the switch. Operation of this switch alternately applies standby power to the OBC or de-energizes the system.

A green ON legend illuminates in the lower left quadrant of the switch when the OBC System is energized. In the standby condition, the lens drive and heater circuits are energized and the film supply spool is under partial power to retain film tension.

A red FAIL legend in the lower right quarter of the POWER switch illuminates to indicate failure during self test or while operating. The FAIL indication can occur as a result of film depletion or improper skew bar air supply. In these cases, the camera reverts to the standby condition if in an operating

mode. A FAIL indication can also be caused by abnormal forward motion compensation (FMC), improper film advance, center of format signal malfunction, malfunction of the capping shutter or if the film has jammed and the film remaining counter is not cycling. In cases where the film has not jammed, the camera will continue to operate.

NOTE

Air for the skew bar and air cage system is obtained from the canopy seal pressure line. The camera will not operate without this supply, and a FAIL indication will occur if a self test is attempted.

The SENSOR FAIL caution light on the RSO's annunciator panel illuminates if a FAIL indication appears on the NOSE OBC panel.

Operate Switch

An alternate action pushbutton OPERATE switch starts and stops the film transport mechanism. After the first successful self test of the OBC system, a white OPR legend illuminates in the upper half of the switch while OBC power is on. Regardless of whether the OPR light is on or off, either a green SRT or an amber STP legend illuminates in the lower left and right quarters of the switch if the power switch is on. The STP legend indicates standby mode.

NOTE

The OPERATE switch should be checked as soon as the power switch is ON. The STP legend should be illuminated. Actuate the OPERATE switch to illuminate STP, if necessary.

Mode Control Switch

A triple action pushbutton MODE switch selects the operating mode, and the percentage of frame overlap in

SECTION IV

OPTICAL BAR CAMERA CONTROL PANEL

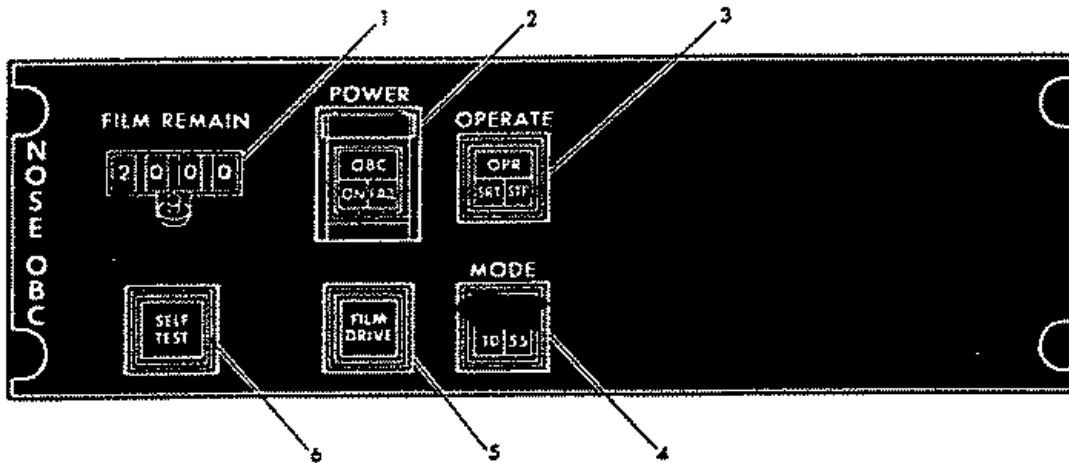

- 1 EXPOSURE REMAINING COUNTER AND COUNTER RESET BUTTON
- 2 CAMERA POWER CONTROL SWITCH AND INDICATOR LIGHT (GUARDED) (WHITE/GREEN/RED)
- 3 FILM DRIVE CONTROL SWITCH AND INDICATOR LIGHT (WHITE/GREEN/AMBER)
- 4 MODE CONTROL SWITCH AND OVERLAP INDICATOR LIGHT (LEGENDS WHITE)
- 5 FILM DRIVE INDICATOR LIGHT (WHITE)
- 6 SELF TEST CONTROL SWITCH AND INDICATOR LIGHT (WHITE)

NOTE

Replaces SLR control panel when operating with the OBC.

F203-177 (6)

Figure 4-29

the [REDACTED]: Illumination of the white [REDACTED] legend indicates [REDACTED]. Illumination of the white 10 or 55 legend indicates that a [REDACTED] has been selected with [REDACTED] frame overlap, respectively. The selection sequence repeats from [REDACTED].

Film Counter

The FILM REMAIN counter indicates the number of exposures remaining. At typical cruise conditions, the counter decreases approximately one unit per 1 3/4 seconds of camera operation [REDACTED]. [REDACTED] is selected. The interval is approximately 3 1/2 seconds in the [REDACTED].

A spring loaded reset button is below the indicator window. The counter rotates to [REDACTED] when the button is pressed. The counter is reset to [REDACTED] or [REDACTED] by the

ground crew before flight. The indication should not be readjusted by the RSO. Refer to Figure 4-28 for the number of exposures vs film load. Counter progression beyond 0000 results in decreasing numbers from 9999.

Film Drive Light

An indicator light displays a white FILM DRIVE legend while the camera is operating. The light is extinguished with the OPERATE switch indicating OPR/STP.

With the OPERATE switch indicating OPR/SRT, the light is turned on by the FILM REMAIN counter. A holding circuit holds the light on for six seconds after the counter is pulsed. Receipt of another impulse during this period resets the light time interval. Since it is controlled by the FILM REMAIN counter pulses, the light will not illuminate or extinguish immediately when the OPERATE switch is actuated.

NOTE

It may be possible to continue operation after a FAIL indication, although degraded imagery is probable. Continued operation of the film transport is indicated by the film drive light and continued cycling of the film counter.

Self Test Switch

The legend in the SELF TEST switch illuminates while the Power Control switch is on. The SELF TEST switch initiates a self test sequence for the OBC System. The test must be initiated while in the standby condition, and 17 to 35 seconds should be allowed for test completion. The camera will not begin self-test without skew bar air. During self test, the camera operates at half the normal speed.

The FILM REMAIN counter indication should decrease five frames during the test, and the FAIL light should remain off. The FILM DRIVE light should not illuminate during self-test. The OPR legend in the operate switch will appear after satisfactory completion of the self-test. FAIL light illumination with termination of camera cycling indicates:

- a. Capping shutter not operating.
- b. Film supply depleted.
- c. Abnormal FMC condition.
- d. Film center of format signal malfunction.
- e. Improper film advance.

OBC NORMAL PROCEDURESPreflight Check

The preflight procedures will normally be completed by the ground crew.

With aircraft electrical or camera power off:

1. OBC nose air supply - Warm air on.

The camera is normally pre-heated in the shop before installation in the nose. After loading, a warm external air supply must provide a stable temperature environment of approximately 105° in the nose.

CAUTION

The camera must not be placed in operation with heated air supplied to the nose. The camera electronic controls and/or power transistors may be damaged.

2. OBC Power switch - Off.

Interior Check

- a. OBC Power switch - Off, (ON and FAIL lights off).

Before Taxiing

With the engines started, canopies closed, canopy seals on, and ground air disconnected:

1. OBC Power switch - ON.

CAUTION

The OBC must be off unless both canopies are closed and the canopy seals are on.

2. Operate switch - STP ON.
3. OBC Self Test - Completed, OPR/STP lights on.

The self test is accomplished as follows:

- a. Operate switch - STP ON.
- b. Mode switch - "10".
- c. FILM REMAIN counter - Check.

SECTION IV

or are the normal indications. Do not reset the counter without the concurrence of the crew chief.

d. SELF TEST switch - Press.

The OPR legend of the operate switch extinguishes immediately, and the FILM REMAIN counter indication decreases five units in approximately forty seconds. The FILM DRIVE light will not illuminate.

The SELF TEST light remains on. Confirm illumination of the operate switch OPR legend, indicating satisfactory conclusion of the test. The power switch FAIL legend should remain off unless a malfunction occurs.

In-Flight

To initiate photography:

1. V/H SOURCE switch - Set.

The OBC normally uses the ship V/H signal selected with the V/H source selector switch. An internally generated value of 40 $\mu\text{r}/\text{sec}$ is provided if the signal is not between 35 to 45 $\mu\text{r}/\text{sec}$.

2. Exposure control system - Set.

Refer to Exposure Control Normal Procedures, this section.

3. OBC Mode switch - As briefed.

4. OBC Operate switch - Check OPR/STP.

5. OBC Operate switch - OPR/SRT.

6. FILM REMAIN counter and FILM DRIVE light - Monitor.

NOTE

There is a 5 to 10 second delay after SRT illuminates before the FILM DRIVE light and FILM REMAIN counter indicate film transport. Steady illumination of the FILM DRIVE light and decreasing FILM REMAIN counter indicate proper camera cycling.

To terminate photography:

1. OBC Operate switch - OPR/STP.

CAUTION

After selecting the standby mode do not reselect SRT for a minimum of ten seconds to avoid film transport damage.

2. FILM REMAIN counter and FILM DRIVE light - Confirm stopped/extinguished.

Confirm that the counter stops cycling and that the FILM DRIVE light extinguishes six seconds after the last counter indication change.

NOTE

Depending on the optical bar position when STP is selected, camera operation may continue for one or two frames before reverting to standby.

Engine Shutdown

1. OBC Power Control switch - Off.

CAUTION

The OBC System is not normally shut down in flight.

OBC MALFUNCTION PROCEDURES

For-FAIL indication during ground self test:

1. SELF TEST switch - Recycle when camera cycling stops.

After camera cycling stops, wait ten seconds and then recycle the SELF TEST switch. If the FAIL indication remains on after two attempts to clear the malfunction, consider the camera inoperative. Notify the crew chief.

For FILM REMAIN counter not decreasing in flight (FILM DRIVE light on or off):

1. OBC Operate switch - STP.

After 10 seconds:

2. OBC Operate switch - SRT. If FILM REMAIN counter is still not decreasing operate OBC normally.

For FAIL light on in flight:

1. OPR/SRT - Check illuminated.

If FILM REMAIN counter is decreasing operate the OBC normally.

If FILM REMAIN counter is not decreasing:

2. OBC Operate switch - STP.

After 10 seconds:

3. OBC Operate switch - SRT.

If FILM REMAIN counter is still not decreasing:

4. OBC Operate switch - STP.

After 10 seconds:

5. OBC POWER switch - Off for 2 seconds (ON extinguished).
6. OBC POWER switch - ON.

Cycling the power switch allows the OBC logic to recycle and go into the correct standby mode if the film has jammed.

7. OBC Operate switch - SRT.

If FILM REMAIN counter decreasing with FAIL light on, operate the OBC normally. Degraded imagery is probable.

If FAIL light on and FILM REMAIN counter is not decreasing:

8. OBC Operate switch - STP for remainder of flight.

If smoke, fire or vibration is apparent from the nose compartment:

9. OBC POWER switch - Off.

CAUTION

The OBC system is not normally shut down in flight.

ELINT IMPROVEMENT PROGRAM (EIP)

The EIP system is comprised of the ELINT (electronic intelligence) equipment in the aft of the left and right aft mission bays. The control switch for the EIP is on the PWR & SENSOR panel on the RSO's right console. The recorder assembly, consisting of a digital recorder and a continuous analog recorder, is in the aft of the left forward mission bay. The ELINT system covers a wide range of frequencies, detecting and recording on magnetic tape information used to determine the operation and location of radiating transmitters within a wide area along the aircraft track. The EIP system is passive, emitting no radiation. It is entirely automatic, and after turn on requires no further adjustment. The system is interfaced with the ANS and MRS for data collection, and with the IFF, TACAN, SLR and DEF to prevent received intelligence from being

SECTION IV

masked by transmissions of those aircraft systems. The ANS must be operating for the EIP to furnish meaningful data; however, the system operates independently of the ANS.

The ELINT system performs two search functions simultaneously: special search, and general search. Special search is based on preflight instructions in the EIP computer, which designate emitters of special interest. Special search function can search the frequency spectrum from [REDACTED]. When a received signal matches the designated emitter, a monitor receiver is automatically tuned to this signal for a pre-programmed period, and the signal pulses are passed to special detectors and recorded on tracks of the continuous analog recorder as video signals to be evaluated with special equipment after landing.

The general search function searches the frequency spectrum from [REDACTED]. This spectrum is divided into 6 bands, all of which are searched simultaneously. Every emitter signal received in the bands is recorded on the digital recorder as to time, frequency, direction, pulse width, and amplitude.

Operating power for the left and right EIP units and the digital recorder is provided by the essential ac bus through circuit breakers in the C-bay. Operating power for the continuous analog recorder is furnished by the 28V monitored dc bus through a circuit breaker in the C-bay.

DIGITAL RECORDER

The digital recorder records general search signals. It is enabled by the ELINT pushbutton switch on the PWR & SENSOR Control Panel and controlled by the ANS program. The maximum recording time is three hours.

If desired, maintenance can program the RCDR pushbutton switch on the PWR & SENSOR Control Panel to control the digital recorder instead of the analog recorder.

CONTINUOUS ANALOG RECORDER

The continuous analog recorder, a 14-channel Ampex Model AR-1700 wide band magnetic tape recorder, records special search signals, ELINT data from the on-board DEF systems, and maintenance data. The recorder can be operated automatically by the EIP system and/or manually by the RCDR pushbutton switch on the PWR & SENSOR Control Panel.

The tape transport operates at 60 or 120 inches per second. A 14-inch reel which supplies 9200 feet of one-inch magnetic tape provides 30 or 15 minutes of recording time per flight. There is no cockpit display of the tape remaining. If the recorder is operated manually, the RSO should log accumulated operating time.

When recorder operation is commanded by the EIP system, recording of ELINT analog data is continuous. This capability permits more comprehensive collection and analysis of ELINT signals.

EIP System Control Switch

The EIP system and the digital recorder are controlled by the ELINT power switch on the PWR & SENSOR control panel. The switch has a white illuminated ELINT legend, a green ON light that illuminates alternately as the switch is depressed, and a red FAIL light that illuminates to indicate failure of the digital recorder. The RSO's master caution light and the SENSOR FAIL annunciator light illuminate if the ELINT FAIL light illuminates.

Recorder Control Switch

The continuous analog recorder (or, if programmed by maintenance, the digital recorder) is controlled by an alternate action RCDR pushbutton switch on the PWR & SENSOR Control Panel. Illumination of its white RCDR legend is controlled by the right console lights rheostat. A green STBY legend illuminates when the ELINT power switch is ON and the continuous analog recorder is in

standby. A green RUN legend illuminates and STBY is extinguished when the recorder switch is pressed. The RUN legend indicates a manual-run command, it is not a positive indication that the recorder is operating. STBY illuminates and RUN extinguishes when the RCDR switch is pressed again. Any interruption of power to the recorder, such as pressing the ELINT switch off, will automatically cause it to revert to standby.

NOTE

The RUN legend will not illuminate when the continuous analog recorder is turned on by the automatic mode.

When operating the recorder allow 9 seconds for the tape transport mechanism to reach a stable speed of 120 ips. A maximum of 10 seconds is required to stop from this speed.

EIP PROCEDURES

To turn the EIP on:

1. ELINT switch - ON.

The system is operational immediately. The continuous analog recorder STBY light illuminates when the ELINT switch is ON.

If ELINT FAIL light illuminates:

2. ELINT switch - Off/After FAIL light off (approx. 15 seconds) - ON.

NOTE

- A 15 second delay is recommended after a power interruption before the system is turned ON.
- If FAIL light reilluminates, the digital recorder is inoperative. The EIP system is operative and the analog recorder can be operated automatically or manually.

If the RCDR STBY light does not illuminate:

3. RCDR switch - Press to illuminate STBY for automatic operation of the continuous analog recorder.

For manual operation of the analog recorder:

4. RCDR switch - RUN.

NOTE

- A maximum of 30 or 15 minutes (60 or 120 inches per second) of recording is available.
- Allow 9 seconds for the tape transport to reach operating speed. A maximum of 10 seconds is required to stop from operating speed.

5. Time - Record.

To stop manual recording:

6. RCDR switch - STBY.

7. Time - Record.

For EIP shutdown:

8. ELINT switch - Off.

V/H (FMC) SYSTEM

The V/H (Velocity/Height ratio) or FMC (Forward Motion Compensation) system provides dc voltage signals through the V/H bus to the cameras to improve photographic resolution. These signals cause the camera mirror or film platen to move in such a way that the terrain image remains stationary on the film during exposure while the aircraft moves forward. The voltages are scaled to represent the angular rate of aircraft forward motion relative to the terrain. The units of motion used are milliradians per second (mr/-sec).

Two types of signals can be developed. V/H is provided when the signal represents

SECTION IV

movement of the aircraft relative to a point directly beneath the aircraft (its nadir point). V/H is approximately the same as true airspeed divided by aircraft altitude. The signal can be generated by the ANS computer, from the optical viewsight system, or by manual inputs using a control on the V/H indicator. At 1835 KTAS and 77,500 feet elevation, $V/H = 40$ m/sec. This is illustrated by Figure 4-30. V/R (velocity/range ratio) allows photographic reconnaissance while turning; that is, when the desired ratio is that of aircraft speed relative to a surface point on the aircraft vertical axis. This is approximately the same as true airspeed divided by (altitude/cosine of the bank angle). V/H and V/R are the same at zero bank angle for vertically oriented cameras.

Both signals can be modified automatically for camera pointing angle commands and aircraft rate of turn to assure optimum FMC. In some cases, the camera using the signal makes an internally computed adjustment. In others, depending on the type of camera, the ANS computer adjusts the signal.

With an optical viewsight installed, four controls operate the V/H system: the V/H Power and V/H Source switches on the Power and Sensor panel, the V/H Monitor switch on the viewsight control panel, and the manual control knob on the V/H indicator on the instrument panel. The traveling grid on the viewsight can be used to check the V/H signal when the viewsight is in wide angle. The Viewsight Rate control can be used to adjust the speed at which the traveling grid moves across the viewsight screen if the grid motion does not correspond exactly to motion of the terrain display.

With a video viewsight installed (S/B R-2538), three controls operate the V/H system: the V/H Power and V/H Source switches on the Power and Sensor panel, and the manual control knob on the V/H indicator on the instrument panel.

Operating power for the V/H system is provided from the essential ac bus through a V/H circuit breaker in the C-Bay.

V/H Power Control Switch

The V/H Power control switch is an internally illuminated pushbutton on the PWR & SENSOR control panel. A white V/H legend is illuminated in the top half of the switch. Green ON and red FAIL legends are in the lower left and right quarters of the switch. Actuation of the switch to illuminate ON indicates that the system is energized and that power is being supplied to the V/H indicator and V/H amplifier. The system is de-energized when ON is extinguished. The FAIL light is not functional.

NOTE

FAIL legends illuminate in the TECH power switches if the V/H system is de-energized while the cameras are operating. (The OBC power switch does not indicate fail if the V/H system is de-energized.) Monitor film counter cycling as a positive indication of normal operation. +

V/H SOURCE Selector Switch

A five-position V/H SOURCE selector switch is on the PWR & SENSOR control panel. It selects the V/H source signal for the V/H bus. V/H bus voltage is regulated by the ANS computer when NAV is selected. Before S/B R-2538, viewsight signals are provided when the switch is in VWSGT. In MAN, the RSO regulates the signal using the manual control knob on the V/H indicator. The LH TECH and RH TECH positions are not functional.

V/H MONITOR Switch

With an optical viewsight installed, a five position V/H MONITOR switch is on the viewsight control panel. It controls the display shown by the V/H indicator A-needle. In NAV, the A-needle displays V/H signals from the ANS. In VS, the A-needle displays V/H signals from the viewsight. In BUS, the A-needle displays the V/H bus signal supplied to the camera(s). The LH and RH TECH positions are not functional.

V/H CHART

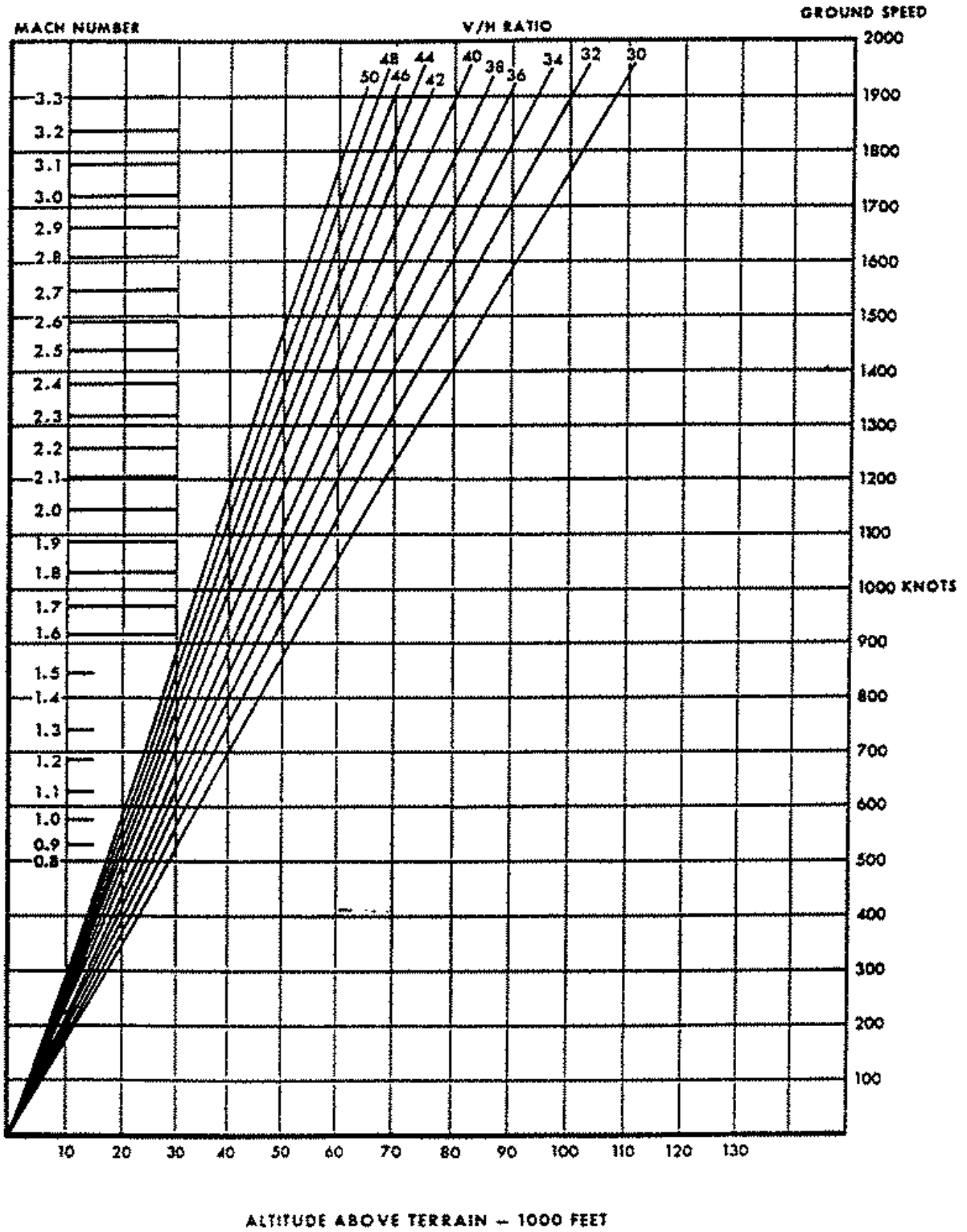

7203-74(116)

Figure 4-30

SECTION IV

With a video viewsight installed (S/B R-2538), the A-needle always displays the V/H bus signal. No V/H monitor switch is provided.

V/H Indicator and Manual V/H Selector Knob

A V/H indicator and manual V/H selector knob are located together on the RSO's instrument panel. The range of the indicator is from 30 to 50 milliradians per second. With an optical viewsight installed, the A-needle indicates the V/H signal obtained from the ANS, the optical viewsight, or the V/H bus as selected by the V/H MONITOR switch on the optical viewsight control panel. With a video viewsight installed (S/B R-2538) the A-needle indicates V/H bus signal. Position of the M-needle is manually controlled by the V/H selector knob in the lower right corner of the V/H instrument bezel. M-needle voltage is supplied to the V/H bus when the V/H source switch is in MAN.

V/H SYSTEM PROCEDURES

The V/H system should operate normally when speed and altitude conditions are such that the aircraft V/H ratio is between 30 and 50 milliradians per second.

To self test V/H:

With optical viewsight:

1. V/H MONITOR switch - BUS.

With the video viewsight, the A-needle always displays the V/H bus signal.

2. V/H SOURCE switch - MAN.
3. Rotate V/H M-needle. Check A-needle follows.

Check that the A and M-needles of the V/H indicator coincide. As the M-needle is moved by turning the manual V/H control knob on the indicator, the A-needle should follow and again coincide with the M-needle.

For normal operation:

1. V/H power switch - ON.
2. V/H SOURCE switch - NAV.

With optical viewsight installed:

3. V/H MONITOR switch - BUS, then as desired.

For V/H system malfunction:

1. V/H SOURCE switch - Set.

With video viewsight:

- a. MAN.

With optical viewsight:

- b. VWSGT or MAN.

Determine a valid source.

With video viewsight installed:

2. Monitor V/H A-needle.

The A-needle indicates V/H bus signal. Check signal validity and stability.

With optical viewsight installed:

2. V/H MONITOR switch - BUS. Monitor A-needle. If the V/H SOURCE switch is in VWSGT, monitor performance of the viewsight traveling grid.

NOTE

- A V/H bus or V/H amplifier failure will cause the A-needle indication to be in error.
- V/H indicator A-needle failure can be confirmed by monitoring the optical viewsight traveling grid.

OPTICAL VIEWSIGHT

Without S/B R-2538, the viewsight in the aft cockpit has a 9-inch diameter optical display at the top of the instrument panel. This ground viewing optical instrument allows the RSO to obtain visual fixes to update the ANS present position, measure V/H, and obtain data for manual operation of the camera systems.

Two fields of view can be used. If the wide angle 136° field is selected, a demagnification ratio of 6:1 occurs and the on-axis resolution at the nadir is approximately 149 feet at normal cruising altitude. The viewsight display is centered at an angle approximately 14-1/2 degrees forward of the nadir. See Figure 4-31. The narrow angle selection provides a demagnification ratio of 2:1 and an on-axis resolution of approximately 46 feet at nadir at cruise altitudes.

The viewsight controls are located on the Power and Sensor control panel, the optical viewsight control panel, and on the bezel of the viewsight display. Short, traveling grid lines across the longitudinal center line of the optical display are used for V/H monitoring and adjustment. The grid lines are displayed only when the wide angle field of view is selected.

The viewsight is unstabilized and will reflect all pitch and roll excursions of the aircraft; however, the ANS compensates for these excursions during automatic viewsight fixing operations.

Viewsight Power Switch

The viewsight power switch on the PWR & SENSOR control panel has a white VWSGT legend illuminated on the top half of the switch. A green ON legend in the lower left quarter illuminates alternately when the pushbutton is depressed. The red FAIL legend in the lower right quarter is not functional.

Viewsight Display Control Knob

A two-position, push-pull knob, labeled MAGNIF, is on the right side of the viewsight bezel. Pushing the knob in provides a 136-degree field of view; pulling the knob out provides 56-degree field of view. The readable scale, reticle image, and nadir line change when the field of view is changed. The traveling grid lines are displayed only when the 136-degree field of view is selected.

CAUTION

The MAGNIF control knob must be moved cautiously when changing the field of view to prevent damage to the optical components.

Cursor Control Knob

A knurled wheel, on the left side of the display case, moves the cursor laterally for locating fix displacement along the nadir line. This control may be used during updating of the ANS.

Cursor Illumination Control

A rotary cursor illumination control knob, labeled CURSOR ILLUM, is located on the left bezel of the viewsight. Clockwise rotation increases cursor illumination.

Read Button

A READ push-button is located on the left side of the display bezel. The pushbutton is depressed to insert a cursor displacement signal into the ANS for error readout when a fix crosses the nadir line.

Reticle Illumination Control

A VIEWSIGHT RETICLE illumination control on the viewsight control panel varies the intensity of reticle illumination.

OPTICAL VIEWSIGHT CONTROL PANEL

An optical viewsight control panel (Figure 4-33) is located in the center of the aft cockpit

SECTION IV

OPTICAL VIEWSIGHT INTERFACE DIAGRAM

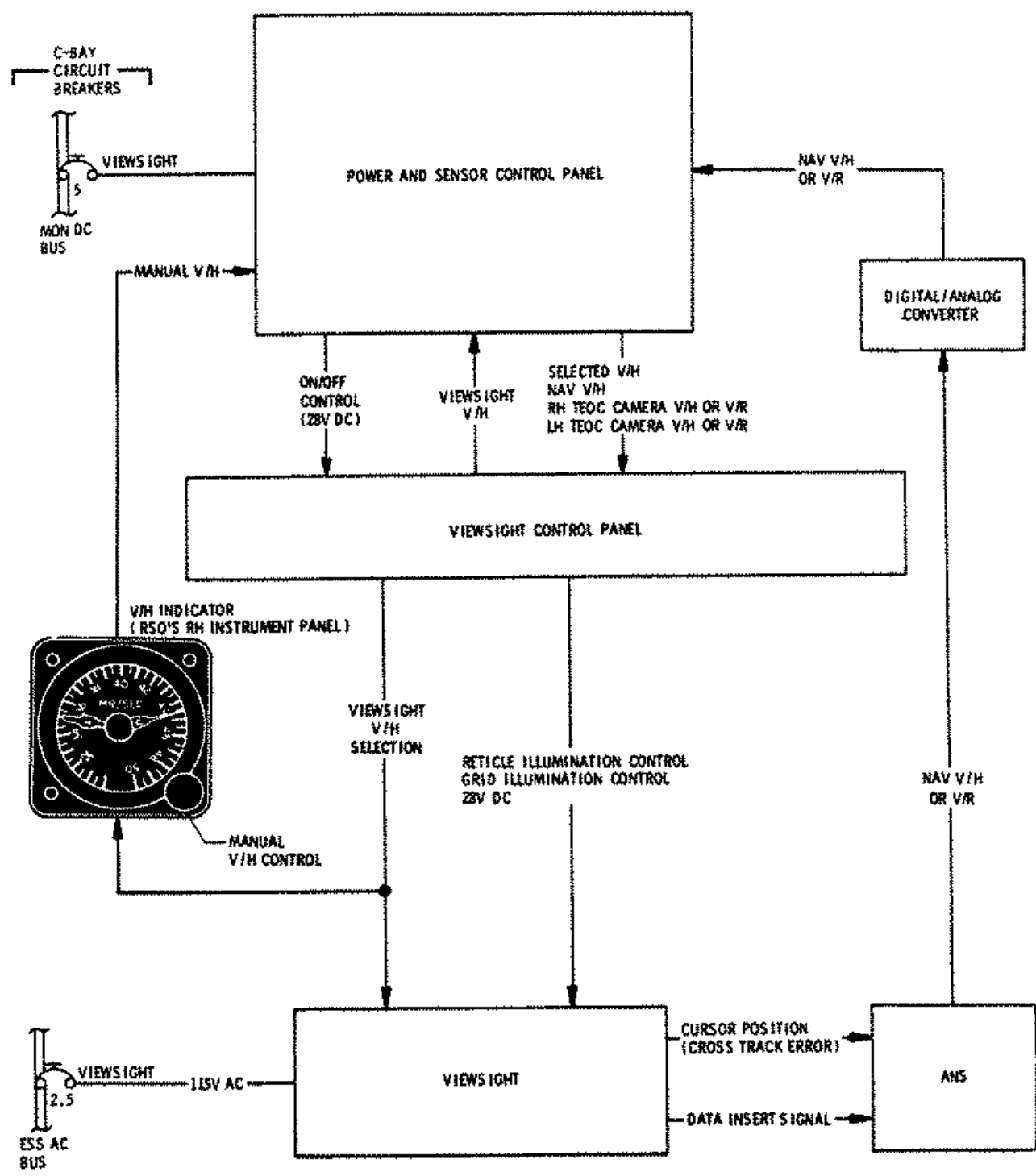

Figure 4-31

F203-51(1)

OPTICAL VIEWSIGHT DISPLAYS

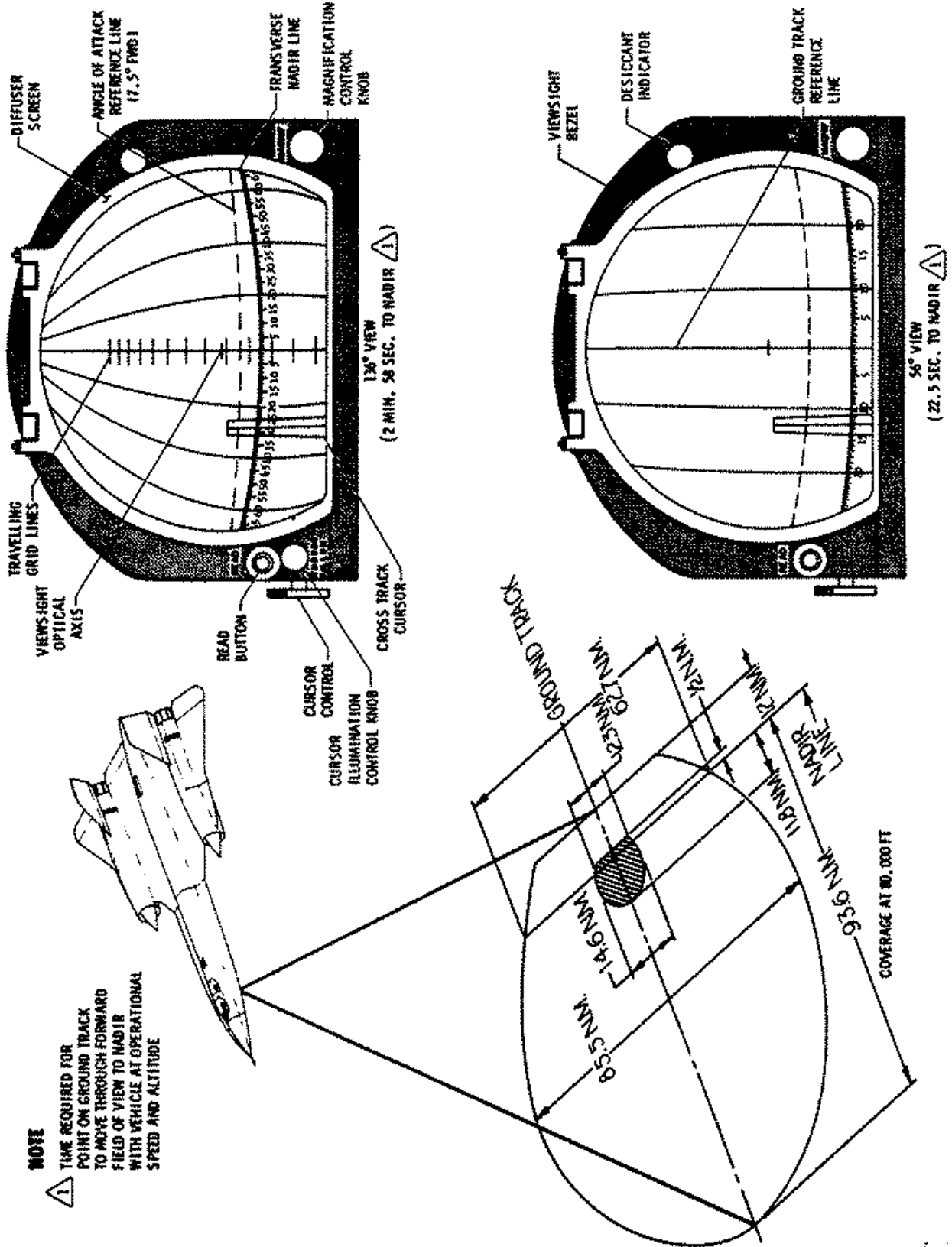
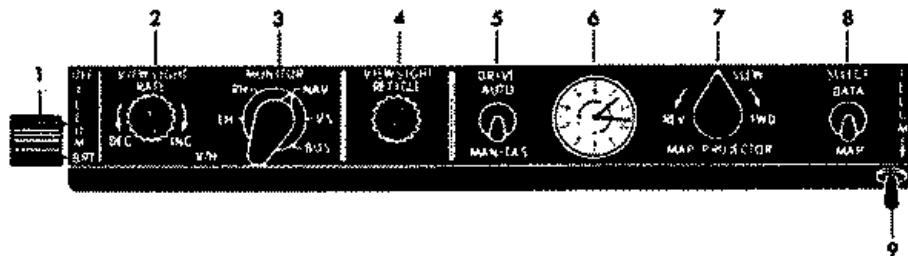

Figure 4-32

F201-33141

SECTION IV
OPTICAL VIEWSIGHT CONTROL PANEL



- | | | | |
|---|---------------------------------|---|-------------------------------|
| 1 | GRID ILLUMINATION CONTROL | 6 | MAP RATE CONTROL AND IND |
| 2 | VIEWSIGHT RATE CONTROL | 7 | SLEW CONTROL SWITCH |
| 3 | V/H MONITOR SWITCH | 8 | FILM SELECT SWITCH |
| 4 | VIEWSIGHT RETICLE ILLUM CONTROL | 9 | PROJECTOR ILLUMINATION SWITCH |
| 5 | MAP DRIVE SWITCH | | |

FIG 4-33

Figure 4-33

instrument panel. The panel contains controls and indicators which are a part of the V/H and nav map projection systems, and are described with those systems.

Viewsight Grid Illumination Control

A viewsight grid illumination control on the left end of the viewsight control panel controls grid illumination. Full counterclockwise is off.

VIEWSIGHT RATE Control Knob

This rotary variable control synchronizes the traveling grid to correspond with terrain view travel across the viewsight display, when VS is selected with the MONITOR switch.

Viewsight Diffuser Screen

The diffuser screen has a vertical grid surface, and is hinged at the top with a detent latch to hold it in a stowed position. Without the diffuser the full screen image is visible only when the eye is 20 inches from the

screen, and within 3/4 inches of the optical axis. As the eye is brought closer to the screen, the visible image disc diameter becomes smaller. When the diffuser is used, the viewer has two eye position capabilities in which lateral eye position is not critical. (Although the vertical dimension will vary when the eye is brought closer than 20 inches to the screen, the visible image will now be rectangular, having a constant, full horizontal dimension.)

OPTICAL VIEWSIGHT PROCEDURES

1. VWSGT power switch - ON.
 2. MAGNIF knob - Wide or narrow field, as desired.
 3. RETICLE illumination - As desired.
 4. Grid ILLUM - As desired.
- To use the viewsight V/H signal:
5. V/H power switch - ON.

6. MONITOR switch - VS.
7. MAGNIF knob - WIDE.
8. VIEWSIGHT RATE - DEC or INC to match V/H grid with terrain movement.
9. V/H SOURCE switch - VWSGT.

To use viewsight for ANS updating:

10. MAGNIF knob - Wide or narrow field.
11. Cursor illumination - As desired.
12. Cursor Control - Align cursor with fix point.
13. READ push-button - Depress when fix point is at nadir.

Do step 14 or 15:

14. UPDATE switch - Press.
Updates present position.
15. MAN CLEAR - Press.
Bypasses updating of present position.

VIDEO VIEWSIGHT (S/B R-2538)

The video viewsight is an electro-optical system in the aft cockpit used for vertical viewing and ANS position fixing. The optics and heat exchanger from the visual viewsight are integrated with a black and white (B&W) video camera, a processor and a 5-inch CRT cockpit display. Power is furnished by the essential ac and monitored dc buses through circuit breakers in the C-bay.

There are two fields of view (FOV). The wide angle FOV is 114 degrees (one-fifth minification) with image resolution of approximately 450 feet at cruise altitudes. The narrow angle FOV is 44 degrees (one-half minification) with image resolution of approximately 225 feet at cruise altitudes.

At a 7.5 degree aircraft deck angle the video imagery is centered about a point 14.5 degrees forward of nadir.

In wide angle FOV the viewed angle is 79.7 degrees forward and 31.9 degrees aft of nadir. In narrow FOV the viewed angle is 39.8 degrees forward and 2.2 degrees aft of nadir.

The viewsight display is at top center of the RSO instrument panel (Figure 4-33A) with system controls to the left of the display on the VIEWSIGHT CONT panel.

The viewsight is unstabilized and will reflect all pitch and roll excursions of the aircraft; however, the ANS compensates for these excursions during automatic viewsight fixing operations.

VIDEO VIEWSIGHT CONTROLS

Viewsight Power Switch

The alternate action push-button power switch is on the PWR & SENSOR control panel. A green ON legend illuminates when power is applied to the viewsight. The FAIL portion of the switch is not functional.

Viewsight Control Panel

Field of View Switch

The two-position FIELD OF VIEW switch selects either wide (up) or narrow (down) FOV. See Figure 4-33D.

Reticle Illumination Switch

The rotary RETICLE ILLUM control varies the reticle intensity independently of the display controls.

VIDEO VIEWSIGHT DISPLAY CONTROLS

Video Control Switches

There are four rocker switches on the display perimeter, one at each corner. The top left switch is not functional.

SECTION IV

Symbology Switch (SYM)

The SYM switch at the top right corner adjusts the intensity of the cursor and legends.

Contrast Switch (CON)

The CON switch at the bottom right corner adjusts video contrast.

Brightness Switch (BRT)

The BRT switch at the bottom left corner adjusts video brightness.

Viewsight Bezel Switches

There are 20 unmarked push-button bezel switches (five on each side of the display). The switches are numbered clockwise starting with switch number 1 on the bottom left-hand side. Only eight switches are active. Except for switches 19 and 20, all are alternate action switches. See Figure 4-33A.

Ambient Brightness Sensors

Two light sensors on the bottom edge of the video display housing automatically vary the display gain for changing cockpit light conditions.

VIDEO VIEWSIGHT DISPLAYS

Bezel pushbutton switch functions and legends change with each of the three viewsight pages (Figure 4-33C).

Menu Page

When power is first applied to the viewsight system the MENU page is displayed.

Bezel 5 - VIEWSIGHT CAL - OK legend
or VIEWSIGHT CAL - NEED legend

Pressing bezel 5 selects the calibration page

Bezel 4 - VIEWSIGHT OPR legend

Pressing bezel 4 displays the viewsight operate page.

Bezel 3 - SELF TEST legend

Pressing and holding bezel 3 displays a six color test pattern with six brightness levels.

Operate Page

Bezel 11 - EXIT legend

Pressing bezel 11 displays the menu page.

Bezel 4 - CURSOR ON legend
or CURSOR OFF legend

If CURSOR ON is displayed, pressing bezel 4 will activate the cursor and associated functions (READ, L, R, and CURSOR OFF legends illuminate). If CURSOR OFF is displayed, pressing the same bezel removes the cursor and associated functions.

Bezel 1 - READ legend

Pressing bezel 1 inserts a cursor displacement signal into the ANS for error readout. The RSO should press this bezel as the fix crosses the nadir line.

Bezel 19 - R legend

Pressing and holding bezel 19 provides slow cursor movement to the right for 3 seconds followed by rapid movement. Cursor movement stops when the bezel is released.

Bezel 20 - L legend

Pressing and holding bezel 20 provides slow cursor movement to the left for 3 seconds followed by rapid movement. Cursor movement stops when the bezel is released.

Viewsight Calibration Page

Bezel 11 - EXIT legend

Pressing bezel 11 displays the menu page

Bezel 12 - CAL DELETE legend (Red)

Pressing and holding bezel 12 for five seconds deletes the existing calibration from memory

(Note: 4-110A thru 4-110G/4-110H Blank deleted)

VIDEO VIEWSIGHT

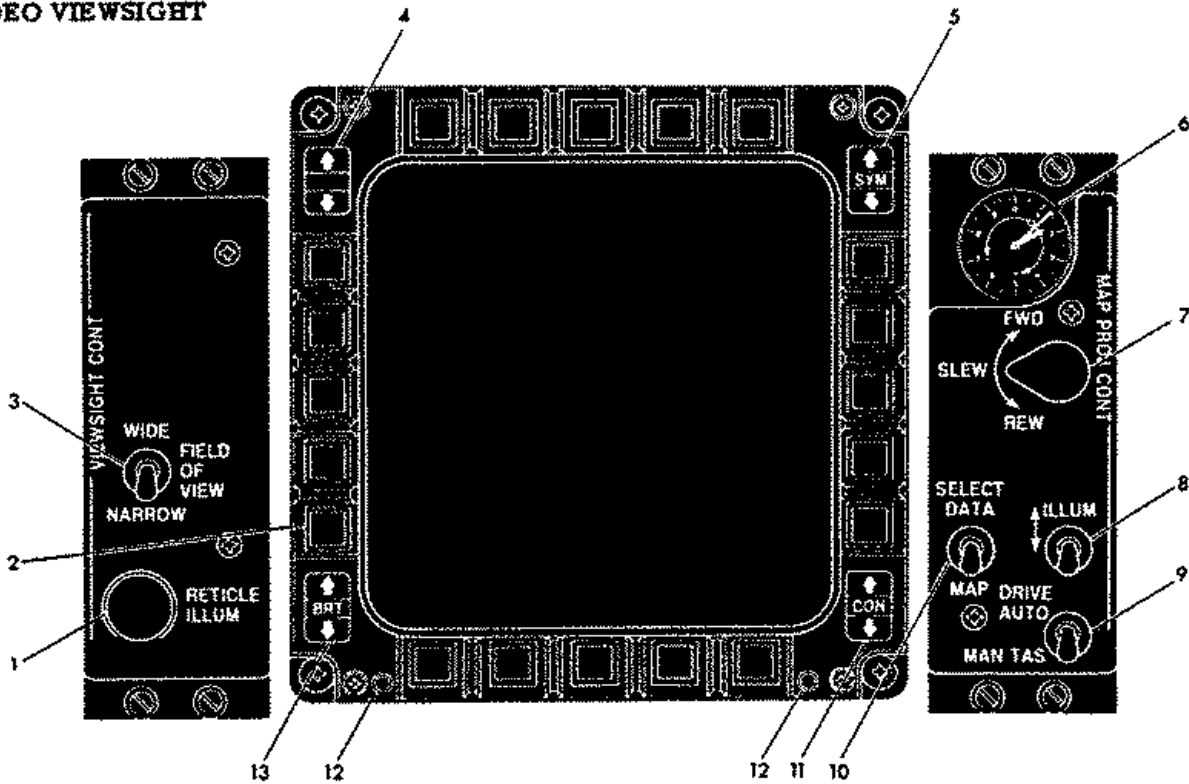

- | | | |
|-------------------------------|---------------------------------|------------------------------|
| 1 RETICLE ILLUMINATION SWITCH | 5 SYMBOLOGY BRIGHTNESS SWITCH | 10 FILM SELECT SWITCH |
| 2 BEZEL PUSHBUTTON SWITCH | 6 MAP RATE CONTROL | 11 VIDEO CONTRAST SWITCH |
| 3 FIELD OF VIEW (FOV) SWITCH | 7 SLEW CONTROL SWITCH | 12 AMBIENT BRIGHTNESS SENSOR |
| 4 UNUSED | 8 PROJECTOR ILLUMINATION SWITCH | 13 VIDEO BRIGHTNESS SWITCH |
| | 9 MAP DRIVE SWITCH | |

Figure 4-33A

F203-31a

and activates the calibration functions (L, R, CAL ENT, and first calibration instruction legends illuminate).

Bezel 5

Calibration instructions appear one at a time in the following sequence after each step is correctly completed and CAL ENT is pressed:

- BW-W-CUR 0° (wide FOV, cursor at 0°)
- BW-N-CUR 0° (narrow FOV, cursor at 0°)
- BW-N-CUR 20° (narrow FOV, cursor at 20° left or right)
- BW-W-CUR 40° (wide FOV, cursor at 40° left or right)

Bezel 4

To enter a correctly completed calibration step into memory, press bezel 4 (CAL ENT legend). CAL OK appears for 2 seconds, then CAL ENT reappears along with the next calibration instruction.

CAL ERROR flashes after CAL ENT is pressed if FOV switch is not set per instruction, CAL ERROR goes off when switch setting is corrected. CAL IN MEM comes on when all calibration steps are entered in memory.

VIDEO VIEWSIGHT PROCEDURES

1. VWSGT power switch - ON.

SECTION IV
VIDEO VIEWSIGHT INTERFACE DIAGRAM

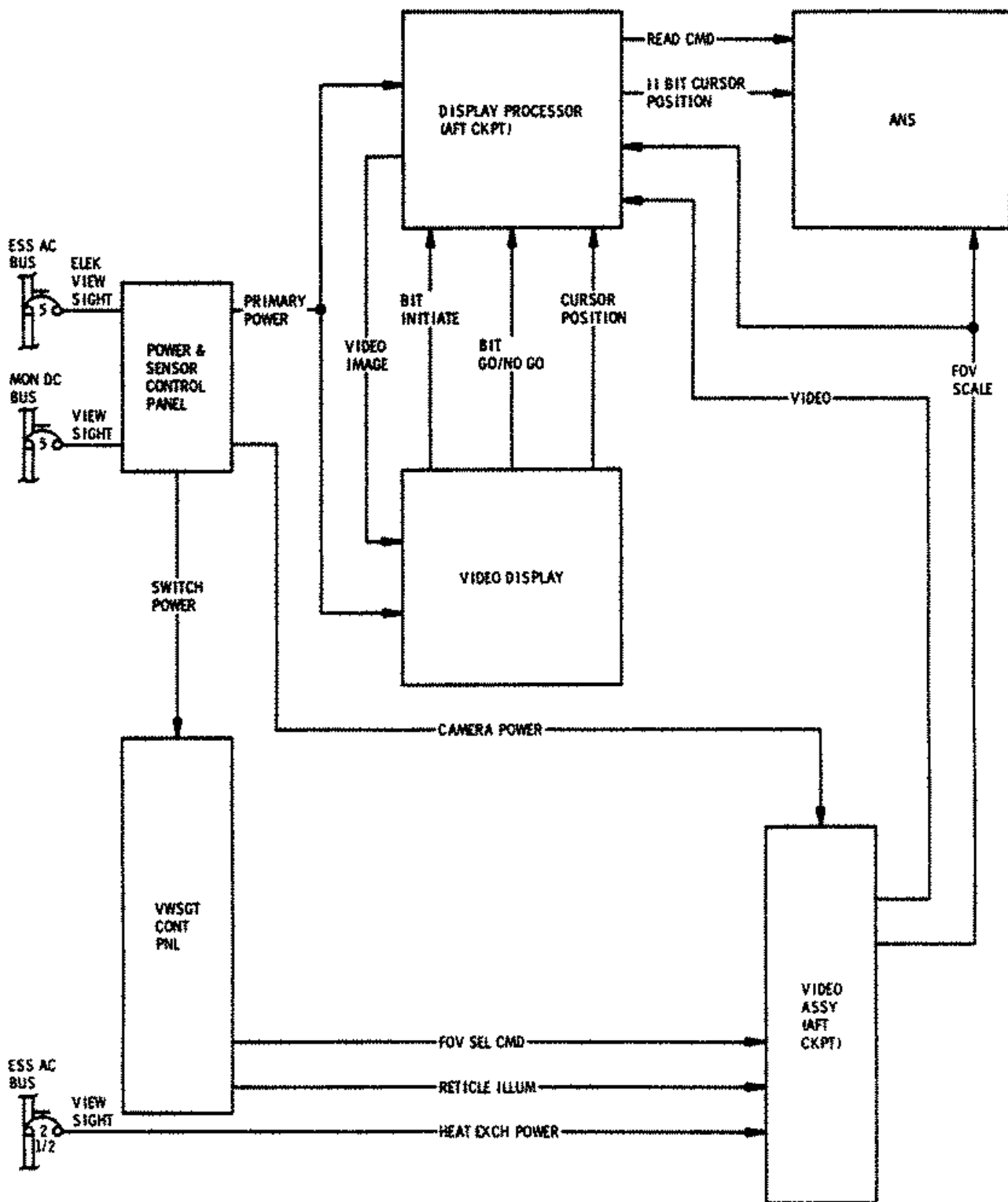

F20-325

Figure 4-33B

VIDEO DISPLAYS

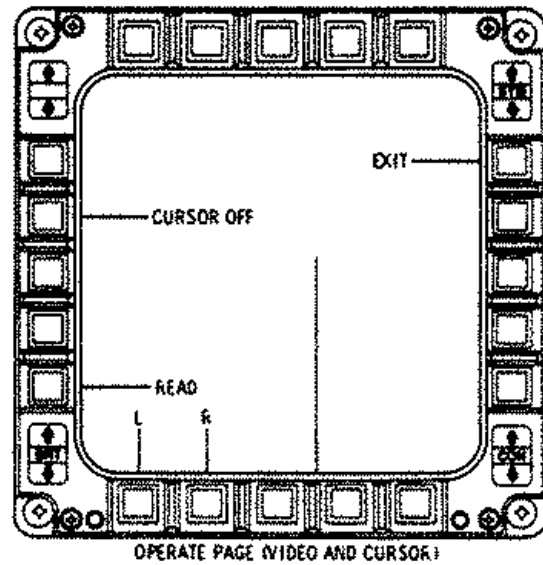
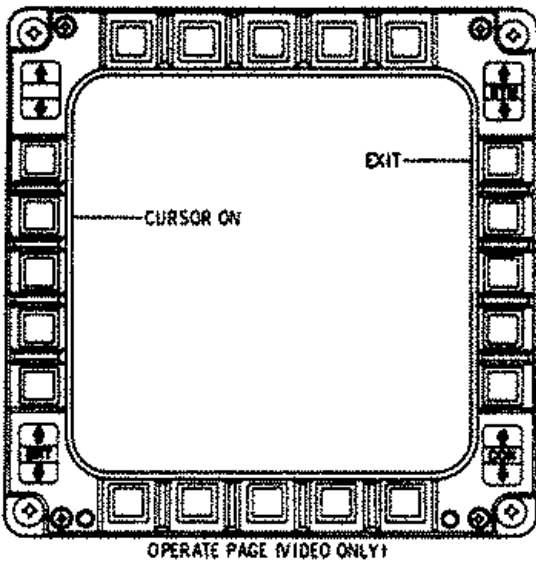
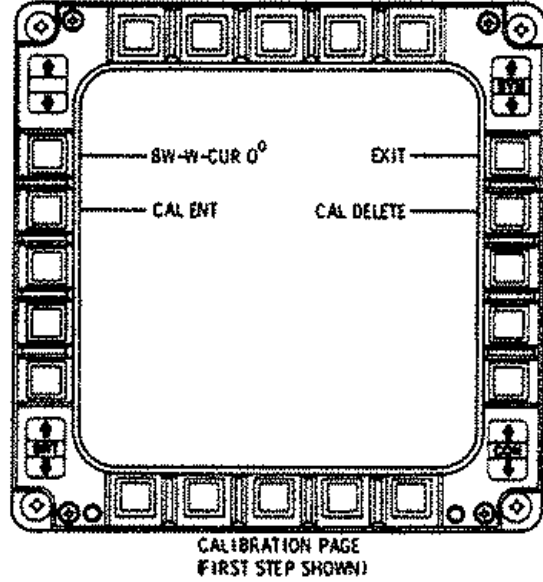
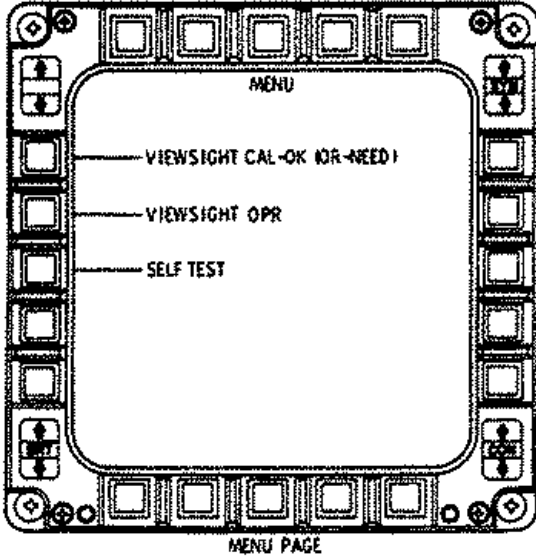

F300-323

Figure 4-33C

SECTION IV

VIDEO FIELDS OF VIEW (FOV)

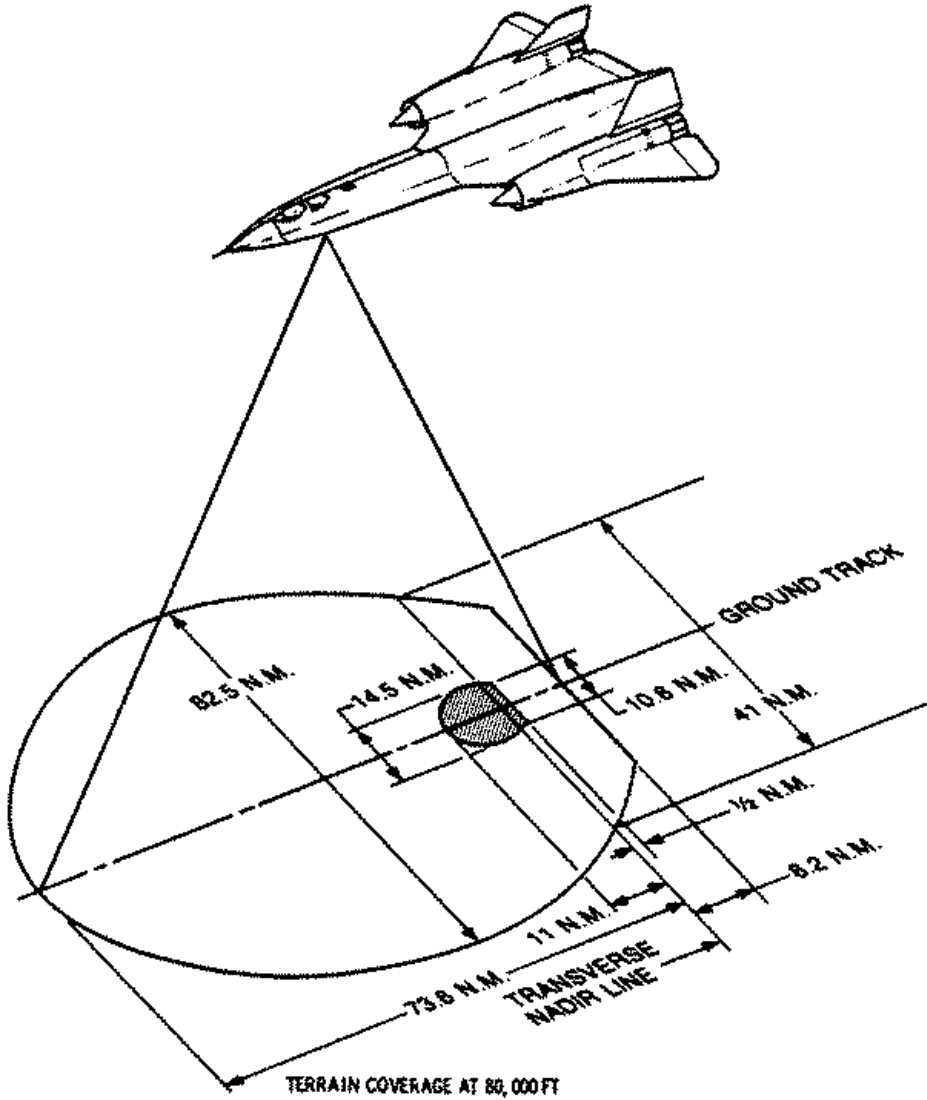
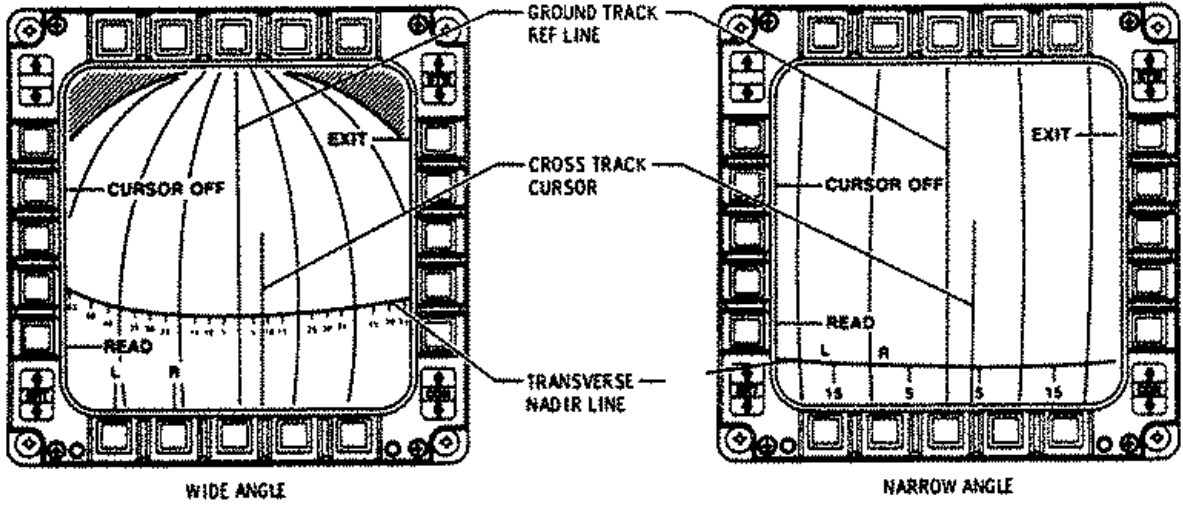

Figure 4-33D

F203-318

2. Video controls - As desired.
3. FOV switch - WIDE or NARROW.
4. RETICLE ILLUM - As desired.

To use viewsight for ANS updating:

1. FOV switch - WIDE or NARROW.
2. CURSOR ON - Press.
3. Align cursor over fixpoint.
4. READ - Press when fixpoint crosses nadir.

Do step 5 or 6:

5. UPDATE switch - Press.
Updates present position.
6. MAN CLEAR switch - Press.
Bypasses updating of present position.

Viewsight Calibration

A calibration may be performed on the ground or inflight in any aircraft attitude. The viewsight reticle must be visible. Calibration is normally accomplished by maintenance.

With viewsight power ON and the MENU page displayed; if VIEWSIGHT CAL-NEED is in view, a calibration is required.

With VIEWSIGHT CAL-NEED on menu page:

1. VIEWSIGHT CAL-NEED - Press.

Calibration page replaces menu page (Figure 4-32B). If CAL IN MEM in view press and hold CAL DELETE for 5 seconds.

With BW-W-CUR 0° displayed:

2. FIELD OF VIEW switch - WIDE.
3. CURSOR - Set 0 degrees.

4. CAL ENT - Press.

Press CAL ENT to enter preceding step in memory. CAL OK will appear for 2 seconds, then CAL ENT will reappear along with the next calibration instruction.

With BW-N-CUR 0° displayed:

5. FIELD OF VIEW switch - NARROW.
6. CURSOR - Set 0 degrees.
7. CAL ENT - Press.

With BW-N-CUR 20° displayed:

8. Cursor - Set 20 degrees (L or R).
9. CAL ENT - Press.

With BW-W-CUR 40° displayed:

10. FIELD OF VIEW switch - WIDE.
11. CURSOR - Set 40 degrees (L or R).
12. CAL ENT - Press.

CAL IN MEM will appear indicating calibration is complete.

13. EXIT - Press.

EXPOSURE CONTROL SYSTEM

An exposure control system provides a scaled voltage signal to the cameras to control the exposure for different conditions of sun angle and terrain brightness. Sun angle, measured from the horizon, is the basic reference for the exposure setting. The rotary selector has 10 sun angle values between 5 and 90, and is set manually by the RSO. Each increment equals one-half stop of exposure setting. In most cases, mission planners will determine correct exposure settings. When mission planning data is not available or is invalid due to a delay in takeoff, the ANS sun angle

SECTION IV

display and RSO observations of terrain reflectivity can be used to set the CAMERA EXPOS control.

Exposure System Control Switch

A self-illuminated exposure system control pushbutton switch on the PWR & SENSOR control panel has a white-illuminated EXPOS legend, in the upper half of the pushbutton. A green-illuminated ON legend, in the lower left portion of the switch, illuminates alternately when the pushbutton is depressed. The exposure control system is energized when ON is illuminated. A red-illuminated FAIL legend in the lower right portion of the switch illuminates to indicate loss of power to, or within the exposure control unit. When the FAIL legend illuminates, and the pushbutton is depressed to extinguish the ON and FAIL legends, a voltage corresponding to nominal exposure (approximately 25-degree sun angle) will be supplied to the cameras from the PWR & SENSOR control panel.

Exposure Control Knob

The exposure control knob (figure 4-34) is on the left instrument panel. The control is set to a sun angle determined from mission planning data. A triangular index is provided for setting the control. The LOW REFL and

EXPOSURE CONTROL

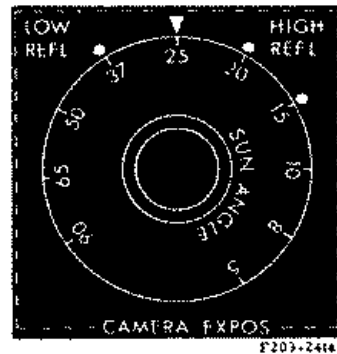

Figure 4-34

HIGH REFL index dots are not used. Setting this knob accurately provides correctly scaled voltage to each type of camera for proper exposure control.

EXPOSURE CONTROL NORMAL PROCEDURES

To operate the exposure control system:

1. EXPOS power switch - ON.

2. SUN ANGLE knob - Set.
3. If mission planning data on CAMERA EXPOS setting is not available or is invalid, display sun angle on the ANS NCD panel, and set the CAMERA EXPOS control as follows:

ANS Sun Angle	Camera Expos	ANS Sun Angle	Camera Expos
57 - 90	65	14.5 - 20.4	20
40.5 - 56.9	50	10.7 - 14.4	15
28.8 - 40.4	37	7.3 - 10.6	10
20.5 - 28.7	25	5.2 - 7.2	8

NOTE

Position 90 is not normally used except for camera resolution ranges having very high reflectance. Over resolution ranges, set CAMERA EXPOS two positions higher than normal. For example, if sun angle is 55 degrees, set CAMERA EXPOS to 50 for intelligence photography, but change to 90 for a resolution range.

EXPOSURE CONTROL EMERGENCY PROCEDURE

If FAIL light illuminates:

1. EXPOS power switch - Off.

A voltage corresponding to a 25-degree sun angle will be supplied to the camera(s) when the EXPOS power switch is off.

MISSION RECORDER SYSTEM (MRS)

The MRS records signals from various aircraft data sources, including analog transducer outputs, digital information sources, voice communications, DEF system, and event information sources. The information is recorded on magnetic tapes.

Power Control Switch

A self-illuminated mission recorder power control pushbutton switch, labeled MRS in the top half, is on the PWR & SENSOR control panel. The switch contains the legends ON in the lower left quarter and FAIL in the lower right quarter. When the switch is depressed the ON legend illuminates to indicate that power is being applied to the recorder. The FAIL legend illuminates to indicate malfunction of the recorder, such as temporary power failure, broken tape, or end of tape.

MRS control power is supplied from the monitored dc bus.

115 volt/400 cycle ac operating power is normally supplied from the No. 1 essential dc bus through a special MRS inverter. Operating power is automatically switched to the essential ac bus to provide continuous recording if the MRS inverter fails. In the event of a double generator failure, a time delay relay (associated with the generator line contactors) allows the inverter to continue for one minute after the second failure. Then inverter operation is terminated automatically to minimize dc loads on the No. 1 battery.

NOTE

After an interruption of power, the MRS switch ON light comes on again when power is restored, but the recorder remains inoperative. To restart the recorder, recycle the switch to extinguish FAIL, then again to illuminate ON.

MISSION RECORDER MALFUNCTION

FAIL light on:

1. Recycle MRS switch.

If the FAIL light remains on:

2. Disregard failure indication.

SECTION IV

CENTER OF GRAVITY CALCULATOR

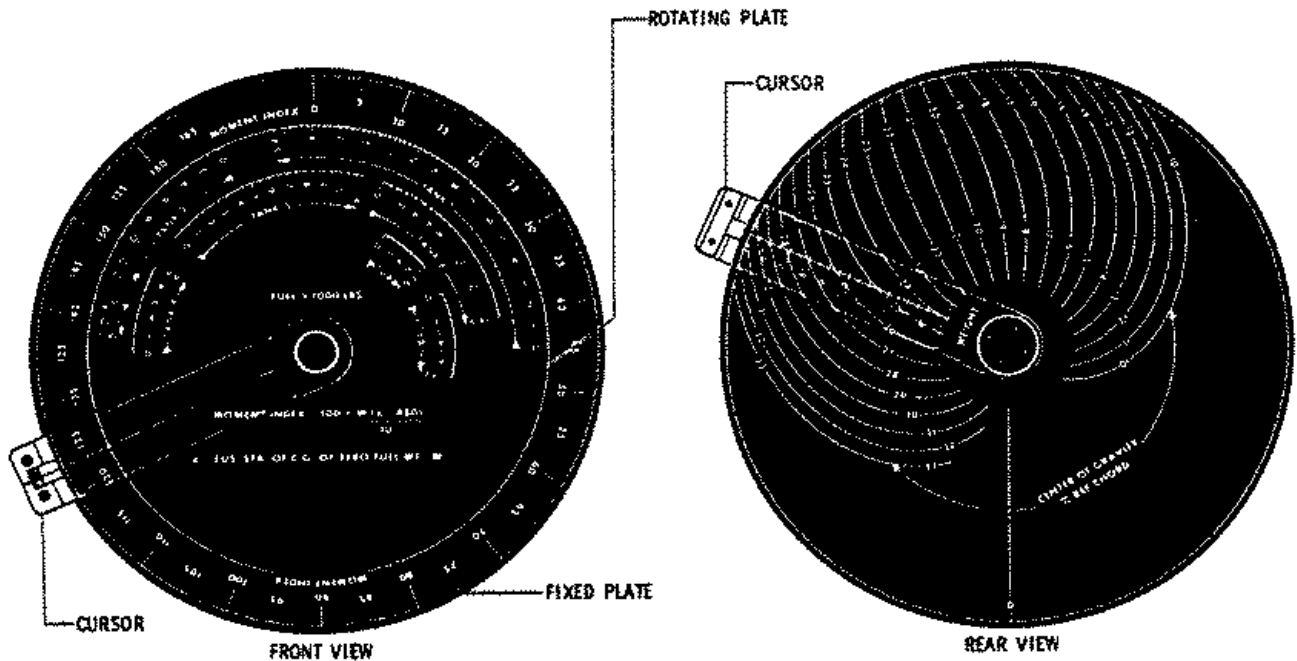

Figure 4-35

F201-115-41

ANS/MRS Dual Format Processor and ANS Recorder

The ANS/MRS dual format processor provides the signals necessary for recording 128 and 32 word ANS telemetry simultaneously. The 128 word format is recorded on the ANS (NAV) recorder and the 32 word format is recorded on the MRS. The essential ac (3Ø) and monitored dc busses provide power for the signal formatter and ANS recorder through circuit breakers in the C-bay. Recording time available with the ANS recorder is approximately eight hours. System control is accomplished by use of the NAV RCDR switch on the PWR & SENSOR panel. ON must be illuminated in the switch to record 32 and 128 word format recordings.

Illumination of the FAIL legend in the NAV RCDR power switch after an ON condition indicates that the ANS recorder is not operating. The ANS recorder is inoperable if recycling the power switch to a NAV RCDR ON condition does not extinguish the FAIL light; however, MRS recording can continue.

CENTER OF GRAVITY (CG) CALCULATOR

The c.g. calculator is a circular slide rule designed to determine aircraft c.g.. The calculator consists of a fixed plate, a rotating plate, and a cursor. The front of the fixed plate has a graduated moment index scale. The rear of the fixed plate has constant c.g. lines in percent reference chord. The rotating plate has individual fuel tank moments, graduated to the same angular moment scale as the front fixed scale, however, these moment scales are labeled in increments of pounds from zero to full quantity. The cursor rotates about the center of the fixed and rotating plates. The front of the cursor has a hairline and the back of the cursor has a weight scale in addition to a matching hairline.

Operation of the C.G. Calculator

- a. Set front cursor hairline to calculator moment index (from aircraft load sheet).

**UNCONTROLLED
COPY**

SR-71A-1

SECTION IV

- b. Hold cursor against fixed plate and turn rotating plate until zero for desired tank is under hairline.
- c. Hold rotating plate against fixed plate and move cursor to quantity in that tank.
- d. Repeat steps b and c for each tank until all fuel is loaded or all fuel remaining has been accounted for.
- e. Hold cursor in last position for fuel load, turn calculator over, and read c.g. in percent reference chord opposite gross weight on cursor hairline.

NOTE

- While on the ground, c.g. computed using the manual c.g. computer should be corrected to allow for the effect of level rather than flight attitude. Refer to Section II, Starting Engines.
- On the ground, when tank 6 is not full, use tank 6A and 6B scale. Fuel distribution must be obtained from mission loading form.

DEFENSIVE (DEF) SYSTEMS

The DEF systems defend the aircraft by electronic means. Arbitrarily assigned letters designate and identify the systems. Systems A2, C2, H and M are currently operational. The DEF equipment installed varies. DEF systems are controlled and monitored by the RSO, using the DEF control panel, on the left console. In addition to the advisory light display on the DEF control panel, a series of DEF advisory lights are arranged on the DEF warning panel, located to the right of the radar RCD display. There are no DEF controls or displays in the forward cockpit.

**UNCONTROLLED
COPY**

DEF CONTROL PANEL

The controls and displays needed to operate all DEF systems are consolidated on a single panel on the RSO's left console. Power control switches, threat warning lights, and status and activity indicators for each system are arranged in rows on the right side of the panel. The rotary controls and lights on the left side are used for fail indications, system reset, testing, and operating mode selection. Two projection displays at the forward edge of the left side provide "GO" and "FAIL" condition advisory information. Refer to Figure 4-36.

Go and Fail Displays

The Go and Fail displays are forward of the mode switches. Go and Fail condition information and DEF system designations are projected on the face of the two displays. The displays indicate results of operator-initiated tests and failures detected during system self-monitor tests. The following legends are provided:

A	LO
C	M HI
	GO

A		LO
	M	HI
FAIL	COMP	HOT

Go Display

Fail Display

(FAIL, COMP, and HOT indications appear in the same position)

LO and HI legends both refer to DEF H. The FAIL, COMP (computer), and HOT legends are red; all others are white. During the warning and control panel lamp test, GO should appear on the Go display and A, LO and HI should appear on the Fail display. There is no DEF C2 designator in the Fail display.

DEF CONTROL PANEL

**UNCONTROLLED
COPY**

Data deleted is classified IAW SR-71 Program Security Classification Guide,
dated 23 September 1996.

The Go display shows the system selected by the SYSTEM SELECT switch (unless the system is not installed in the aircraft). The system designation remains illuminated until repositioning the SYSTEM SELECT switch extinguishes the designator. The word GO does not appear in the Go display until a self-test is satisfactory. A failure condition after self-test will not extinguish the GO.

Normally, the Fail display is blank. FAIL and the corresponding system designator illuminate if a system malfunction is detected. HOT or COMP (computer) also can appear instead of FAIL. The HOT display applies to DEF A2 and H systems. COMP applies only to DEF H. More than one legend can be displayed simultaneously. In this

event, it is possible for the FAIL, HOT, and/or COMP legends to be superimposed.

GO and FAIL can illuminate almost simultaneously during system tests. Except for self-tests of the DEF H and M systems, a GO display is locked in when it appears. It stays illuminated until the SYSTEM SELECT switch is repositioned. FAIL can appear as a result of a subsequent failure during the self-test sequence, or as a result of a failure of another system while the self-test is in progress. (In this latter case, another legend would appear in the Fail display.)

With DEF H, a HI FAIL erases a LO GO display, and a LO FAIL erases a HI GO. In DEF H, the self-test is a single function. That is, a GO is a GO, and a FAIL is a FAIL for the entire system.

**UNCONTROLLED
COPY**

**UNCONTROLLED
COPY**

SR-71A-1

SECTION IV

DEF Power Switches

Three alternate action pushbutton switches (labeled A, F/H, and M) control power for the DEF systems. White legends in the upper half of these switches illuminate to display the designations of the systems installed. When DEF H is installed, the F/H power switch may illuminate F for semi-automatic or H for fully automatic state. The DEF C2 system is turned on when the A, M, or F/H power switches are ON, and is turned off when the A, M, and F/H power switches are off. If no other system is installed, DEF C2 may be turned on (self-test, for example) by pressing one of the power switches. However, the switch must be held pressed as there is no interlock signal present to hold the switch in ON. When the A, F/H, and/or M, power switches are first pressed, the green ON and amber W (warm-up) legends illuminate in the lower left and right quarters of the switches. The system legends, inscribed in the corresponding status switches, also illuminate when their systems are turned on. When the system warm-up is completed, the power switch W legend extinguishes, and the amber S (standby) legend illuminates in the system status switch.

Interlocks prevent the systems from being turned on accidentally when the electrical system is turned on. If a system is not installed, the ON and W legends cannot be illuminated by power switch actuation.

The normal initial warm-up periods are:

<u>DEF System</u>	<u>Time (min)</u>
A2	3
C2	0
H	5
M	3

**UNCONTROLLED
COPY**

NOTE

- If system H does not go to standby after six minutes from system turn-on, the probable cause is an open circuit breaker in the C-bay.
- If system H is in standby, then goes to warmup without any crew action the probable cause is an open circuit breaker in the C-bay. Any threat indications that were illuminated will extinguish.

The left console light control rheostat regulates the intensity of the power and status switch legends, but not the intensity of the colored lights.

Threat Warning and Activity Indicators

The threat warning light legends, directly associated systems, and corresponding activity indicator lights are discussed under the descriptions of the associated DEF systems.

Status Switches

Seven alternate action switches are provided to control the standby (S)/operate (O) state of the DEF systems installed. Only those five switches associated with DEF A2, H, and M systems are functional. DEF C2B does not have a standby state; it is either on or off as determined by pressing a DEF power switch (A, M, or F/H). The status switch system designation legend illuminates when the associated power switch is ON. The status switch S legend illuminates at the end of system warm-up, as the W legend on the associated power switch extinguishes, to indicate that the associated system is in a standby state. Pressing the status switch extinguishes the S legend and illuminates the O legend and begins system operation. Pressing the status switch alternately shifts the system to operate (O) or standby (S). The DEF H system S/O

**UNCONTROLLED
COPY**

switch will not function like the other status switches until the HI operate status switch is on.

Auto/Manual Mode Switches

The SYSTEM SELECT switch and three 3-position, self-centering AUTO/MAN mode switches control the operating modes of the DEF H system in the low and high frequency ranges. The mode selection in effect is indicated by illumination of the corresponding numbered automatic (A) or manual (M) mode indicator lights located in two rows along the bottom edge of the control panel.

*Deleted IAW
SR71 SC6
23 Sep 76*

**UNCONTROLLED
COPY**

Mode selection is accomplished by positioning the SYSTEM SELECT switch to H LO or to H HI, and then momentarily turning the numbered AUTO/MAN mode switches to the required AUTO or MAN position. The switches are spring-loaded to the neutral position. Mode selection can be made while in either S or O.

To cancel a mode selection, make the same selection again. The LO and HI band mode indicator lights confirm the settings in effect. Manual mode selections override the corresponding automatic settings. However, when the manual mode is cancelled, the system reverts to the previously selected automatic mode unless it also has been cancelled.

NOTE

Jamming is inhibited if all modes are cancelled, but the threat warning indicators remain operative.

Fail/Reset Switch

A single action switch, inscribed with a white RESET legend is right of the SYSTEM

SELECT switch. When illuminated, a red FAIL legend is visible in the upper half of this switch. The FAIL legend will illuminate simultaneously with the FAIL, HOT, or COMP legend and the system designator in the Fail display if the system malfunction is a type which can be reset; for example, a power transient during turn-on. Press the RESET switch to initiate reset. It is not necessary to set the SYSTEM SELECT switch to the corresponding system. The system designator and the FAIL, HOT, or COMP legends extinguish when the system returns to normal operation.

NOTE

The Fail/Reset switch only applies to DEF H. Systems A2, C2, and M have no Fail/Reset indications.

Test Switch

An alternate action switch, with a white TEST legend, is below the RESET switch. When illuminated, a green ON legend is visible in the lower half of the switch. It is used with the SYSTEM SELECT switch to start or stop the self-test for individual systems. To start a test, set the SYSTEM SELECT switch to the desired system and press the TEST switch. Illumination of GO in the Go display during the sequence indicates a satisfactory self-test unless a Fail display indication also appears for that system. (See Fail Indications/Malfunction Procedures for the individual systems.) The self-test ON legend will extinguish automatically after a self-test is started (10 seconds for A2; 12 seconds for C2; 26 seconds for H; and 5 seconds for M). A self-test can be terminated during the sequence by repositioning the SYSTEM SELECT switch or by pressing the TEST switch again to extinguish ON. However, a self-test of the same system or of another system cannot be started until completion of the self-test time-out period for the interrupted system; for example, 12 seconds for DEF C2.

The DEF A2 system must be tested in tl mode; therefore an external transmission occurs. DEF H can be tested in either the S

**UNCONTROLLED
COPY**

SR-71A-1

SECTION IV

or O mode. The choice is dependent on whether an external transmission legends illuminated) is desired.

System Select Switch

A five-position rotary SYSTEM SELECT switch enables self-testing the individual systems, and selects DEF H AUTO/MAN operating mode indicators. The corresponding system legend (A, C, M, or LO/HI for H) in the Go display illuminates when an installed system is selected with the SYSTEM SELECT switch. System selection must be made before initiating mode selection or a self-test. Selecting OFF, or repositioning of the switch while a self-test is in progress terminates the self-test. Do not initiate self-test of another system until completion of the full time programmed for the first self-test.

NOTE

The low and high bands for DEF H cannot be self-tested independently. Selection of either F/H LO or F/H HI automatically results in consecutive self-testing of both low and high bands. The FAIL legend can be displayed for either band. A GO legend will be shown only for the selected band. Lack of a FAIL legend for the band not selected implies a GO.

Control Panel Lighting

The GO display, FAIL display, threat warning indicators, and H LO and H HI activity indicators are powered by the 28 V monitored dc bus through the DEF CONT circuit breaker on the RSO's right console. Panel and title lights for the DEF power switches, the RESET switch, and the TEST switch are powered by essential ac bus power through the L console PNL circuit breaker on the RSO's left console. All other lights on the DEF panel are powered by the essential ac bus through the L console LGD circuit breaker on the RSO's left console.

Lamp test for the DEF control panel is accomplished by pressing the LAMP TEST

switch on the PWR & SENSOR control panel. This tests all indicators on the DEF warning panel and all lights and displays on the DEF control panel except the Go and Fail displays. Only the GO will illuminate in the Go display (A, C, M, LO, and HI will not illuminate), and only the A, M, LO, and HI will illuminate in the Fail display (FAIL, HOT and COMP will not illuminate).

DEF WARNING PANEL

The DEF warning panel is on the RSO's instrument panel, right of the viewsight. It directs the RSO's attention to the DEF control panel if a threat or failure involves the DEF systems. See Figure 4-37. Seven red or amber warning legends are on the panel: these are [REDACTED]

[REDACTED] DEF FAIL illuminates when FAIL, HOT, or COMP is displayed in the Fail display on the DEF control panel. The other warning indicators repeat like indicators on the DEF panel, and therefore illuminate simultaneously with those indicators. [REDACTED]

Deleted IAW SR71 SCG 23 Sept 96

[REDACTED] The significance of the various warnings is discussed under the descriptions of the associated DEF systems. Power for indicators on the warning panel is supplied by the monitored dc bus through the DEF CONT circuit breaker on the RSO's right console.

DEF A2 SYSTEM

DEF A2 is a [REDACTED] jammer ECM system with two sets of receive and transmit antennas, and a gaseous nitrogen system to pressurize the transmit waveguides. DEF A2 can respond to signals typical of [REDACTED] radars in the [REDACTED] band-frequency ranges of [REDACTED]. The antennas receive signals from emitters below the aircraft. The system identifies threat aircraft in the left or right forward quadrants.

**UNCONTROLLED
COPY**

Change 1 4-123

**UNCONTROLLED
COPY**

*Deleted Ipw SR71 SGG
23 Sept 76*

DEF A2 can be installed in the forward right chine bay (Compartment D). See Figure 4-37. The antennas and waveguides are permanently installed. The left and right transmit antennas protrude slightly from the lower surfaces of the chines, opposite the pilot's cockpit. The receive antennas are located aft of cut-outs on the left and right sides of the nose chines. The DEF A2 system is interfaced with the MRS, the Radar, and the EMR system.



DEF A2 signals are applied to the AR-1700 recorder when mission requirements dictate. DEF A2 operation, indication, and control data is recorded by MRS.







Electrical power to DEF A2 is supplied from the essential ac bus and the monitored dc bus through circuit breakers in the C-bay. See Figure 4-38.

Cooling air is supplied directly to the DEF A2 repeater through an air duct and hose, which are connected to the aircraft cooling air duct during DEF A2 installation. Air flow is from the right mission bay air manifold and is controlled by the right mission bay air shutoff valve.

DEF A2 Threat Warning & Activity Indicators

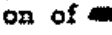
Threat warning indications are provided by the  and LT/RT legends on the DEF control

panel and LEFT/RIGHT legends on the DEF warning panel. These indicators are operable in either the standby (S) or operate (O) mode. The  legend indicates  threat signal which exceeds the threshold setting of the system. The RT(RIGHT) and LT(LEFT) legends indicate receipt of a threat signal from either the forward right or forward left quadrant. Only one legend illuminates at a time, indicating the side with the greatest threat.



Jamming  activity is indicated by the  and  legends on the DEF control panel. Illumination of  indicates adequate transmitter output power. Illumination of  indicates transmission of a  threat signal. If both  threat signals are received, DEF A determines which signal represents the most significant threat and responds accordingly.

*Deleted Ipw
SR71 SGG
23 Sept 76*

**UNCONTROLLED
COPY**

DEF A2 Operation

DEF A2 is turned on and off using the DEF A power switch. Pressing this switch to illuminate ON supplies power to the DEF A to place it in a warm-up state, and illuminates the W legend on the power switch and the A legend on the DEF A status switch. Pressing the power switch to ON also turns on the DEF C2 system (not a part of DEF A2). Approximately three minutes after power is applied, the W legend extinguishes and the S legend on the status switch illuminates. This indicates warm-up is complete and the system is in S (standby).

In the S mode, DEF A2 threat recognition and signal source direction circuitry are active. The  /LT/RT threat warning indicators on the DEF control panel and the  LEFT/RIGHT indicators on the warning panel may illuminate; however, jamming is inhibited.

SR-71A-1

DEF EQUIPMENT LOCATION

UNCONTROLLED COPY

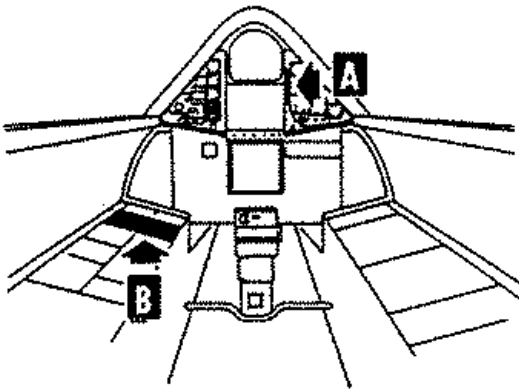

*Deleted IAW
SR71 SCG
23 Sept 96*

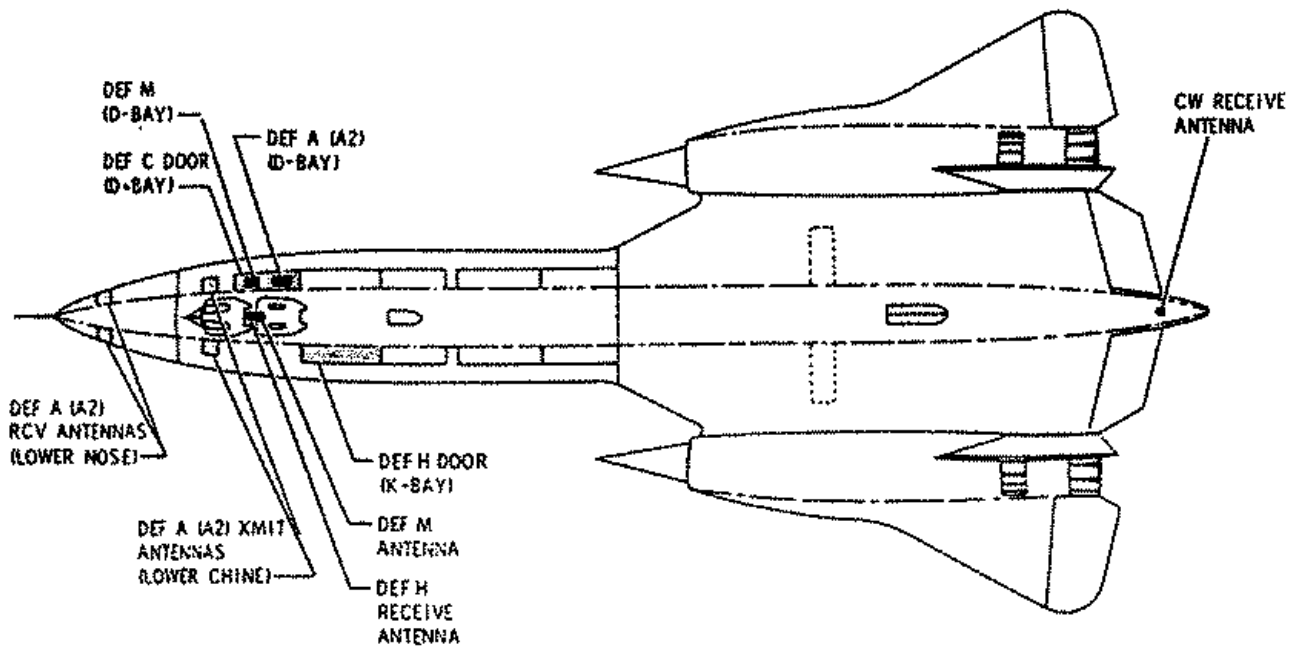

UNCONTROLLED COPY

F203-209(c)

Figure 4-37

**UNCONTROLLED
COPY**

SR-71A-1

SECTION IV

DEF A2 is in the operate mode when the A status switch is pressed to illuminate the O legend. In this mode, DEF A2 automatically changes from passive receiving to ~~transmitting~~ jamming. Illumination of the ~~ON~~ legend indicates that DEF A2 is ~~in the operate mode~~ (jamming) received rf threat signals.

DEF A2 Normal Procedures

To turn on DEF A2:

1. A power switch - Press to illuminate ON.

The ON and W (warm-up) legends illuminate. If the SYSTEM SELECT switch is in A, A illuminates in the Go display. In approximately three minutes, the W legend extinguishes and the S (standby) legend in the status switch illuminates.

NOTE

Jamming is inhibited in the S mode, but the threat warning lights are operative.

After warm-up is complete:

2. A status switch - Press to illuminate O.

The S legend extinguishes and the O (operate) legend illuminates. Jamming operations are automatic in the O mode.

3. Self-test - Complete.

Refer to DEF A2 Self-Test.

To return to the S mode:

1. A status switch - Press to illuminate S.

The O legend extinguishes and the S legend illuminates.

To turn off DEF A2:

Ensure that the system is in the S mode before turning off power.

1. A power switch - Press to extinguish ON.

NOTE

Remain in the S mode after descent if it is desired to retain an immediate response capability.

DEF A2 Self-Test

Self-tests must be accomplished in the operate mode with the SYSTEM SELECT switch in A. During self-test, a self-generated pulse signal is introduced into the left channel to check the ~~ON~~ mode, and a self-generated ~~ON~~ signal is introduced into the right channel to check the ~~ON~~ mode. The test takes ten seconds.

WARNING

Due to the ~~ON~~ radiation levels generated by a DEF external transmission, set DEF systems to standby and do not conduct self-test during air refueling.

NOTE

Illumination of the ~~ON~~ legend during any self-test indicates an actual external transmission.

To self-test DEF A2:

1. A status switch - O illuminated.

2. SYSTEM SELECT switch - A.

The A legend appears in the Go display.

3. Test switch - Press to illuminate ON.

Check for the following light indications:

- a. Test switch ON legend remains illuminated for 10 seconds.

- b. The following legends illuminate for the first five seconds and then extinguish:

legends on the DEF control panel;
~~ON~~ legends on the DEF warning panel.

**UNCONTROLLED
COPY**

**UNCONTROLLED
COPY**

- c. For the next five seconds, the following legends illuminate and then extinguish:
legends on the DEF control panel;
legends on the DEF warning panel.
- d. The GO legend in the Go display illuminates immediately and stays illuminated until the SYSTEM SELECT switch is repositioned.

If any of the above indications do not appear and/or the FAIL/HOT legend illuminates, refer to DEF A2 Malfunction Procedures.

NOTE

Any self-test can be terminated while the test is in progress by repositioning the SYSTEM SELECT switch. However, a self-test of the same system or another system cannot be started until completion of the original test duration period.

4. A status switch - Press to illuminate S.

Return the system to S unless operational conditions dictate otherwise.

DEF A2 Malfunction Procedures

NOTE

The control panel RESET switch will not reset DEF A2.

1. Electrical Fault

In the operate mode, the ~~high~~ high voltage supplies and the pulser circuit are monitored. If any of these circuits fail, the A and FAIL legends on the control panel Fail display and the DEF FAIL legend on the DEF warning panel illuminate.

If the above conditions are present and the XMIT light does not illuminate during self-test or in response to a threat while in operate, an under/over

voltage condition or tube ionization could be present. In this case, remain in O (S extinguished) for no more than twenty seconds after completion of the DEF A2 System Self-Test before returning to the S mode. Remaining in operate after the System Self-Test is complete will enable the system Fault Generator. The generator monitors various fault signals and system current levels. If a fault is detected, the Fault indicator is enabled and the appropriate MRS signal is generated. A 4-6 second timer is then allowed to check fault processing circuits. In essence, the system will attempt to correct the malfunction and return to normal fault-free operation. Fault Generator activation should clear any transitory fault condition. If corrected, the system will be reset and provide normal Self-Test indications on subsequent Self-Tests.

If the system fault is not corrected by Fault Generator activation, attempt to reset the system by recycling the power switch off for 10 seconds to ON.

If the XMIT portion of the system is disabled, remain in the S mode to receive threat warning indications observed to be operable during the Self-Test.

CAUTION

If the following indications are present during the DEF A2 System Self-Test, do not allow the system to remain in O (Self-Test completed) more than 20 seconds to prevent equipment damage: XMIT Light extinguished, A and FAIL legends on the control panel Fail Display and DEF FAIL legend on the DEF Warning Panel illuminated.

**UNCONTROLLED
COPY**

UNCONTROLLED
COPY

SR-71A-1

SECTION IV

NOTE

Either [redacted] side can cause a FAIL indication. The [redacted] side will operate normally if the [redacted] side fails; however, if the [redacted] high voltage power supply fails, the system will return automatically to the S condition, and attempt to update the operate condition at six-second intervals. The FAIL legend will blink at six-second intervals. For operational missions, leave the system in O; otherwise, return to S.

2. Low RF Power

Low rf power is indicated by the XMIT legend being extinguished when the [redacted] legend is illuminated in operate. No FAIL legends will be illuminated.

Recycling the system power probably will not correct the malfunction. If time and conditions permit, leave the power off for a period of time and then reattempt normal operation. If the condition was transitory in nature, the system may later operate normally.

3. Overheat Fault

A temperature switch on the DEF A2 main chassis monitors the system for an over-temperature condition. The signal provided by this switch illuminates the A and HOT legends on the DEF control panel Fail display and the DEF FAIL legend on the DEF warning panel.

In this event, the system should be placed to S then turned off. If may be possible to operate the system again after a cool down period. The system may be operated in a tactical threat situation, even with the HOT legend illuminated. In this case, the receiver may operate normally, but the transmitter will operate at reduced power until FAIL illuminates.

CAUTION

If the DEF A2 HOT legend illuminates, the system shall be turned off as soon as possible to minimize damage to the system. However, the system can be left in the operate mode until FAIL appears, if an appropriate threat condition exists.

DEF C2 SYSTEM

The DEF C2 system receives and processes [redacted] signals in the [redacted] frequency band of [redacted]. The DEF C2 receiver is associated with [redacted]: operation of the DEF H system.

Deleted

I A W

UNCONTROLLED
COPY

SR71

SCG

23 Sept 96

**UNCONTROLLED
COPY**

NOTE

When installed, DEF C2 system components are on the forward right chine bay door (Compartment D). See Figure 4-37. Components include the DEF C2 receiver, band antenna, band-pass filter, DEF C2 power relay, and electrical and coaxial cables. DEF C2 operates in conjunction with DEF H and the MRS.

Electrical power to DEF C2 is supplied from the monitored dc bus through a circuit breaker in the C-bay. See Figure 4-39.

Cooling air is supplied to the components on the DEF C2 door by air supplied to the right chine bay from the right mission bay cooling air manifold.

DEF C2 Threat Warning & Activity Indicators

Since DEF C2 does not require a warm-up period, its threat warning legends are operational as soon as DEF A, DEF M, or DEF H power is on.

*Deleted IAW SR71 566
23 Sept 96*

Analysis and display characteristics of DEF C2 are independent of other systems' operation.

threat warning legends are provided on the DEF control and warning panels.

the legends on the DEF control panel and on the DEF warning panel illuminate steady.

On receipt of an legend signal from DEF C2, the DEF H system is triggered into operation, provided it is set to the proper operating status.

- DEF H will not transmit upon display of a DEF C2 . In this case, the DEF H legend also will be illuminated. However, the legend is associated with the DEF C2 receiver, and will not illuminate unless an associated legend is illuminated.
- In the mode, DEF H will transmit when an legend illuminates if the proper modes are selected.
- During refueling rendezvous, the UHF may cause erroneous indications if operated in the external mode, and approximately higher in frequency.

DEF C2 Operation

DEF C2 is turned on by pressing the DEF A, DEF M, or DEF F/H power switch (provided one of these systems is aboard the aircraft). DEF C2 is operational as soon as the DEF A, DEF M, or DEF F/H power switch is ON. To turn off DEF C2, the DEF A, DEF M, and DEF F/H power switches must be off.

DEF C2 Normal Procedures

To turn on DEF C2:

1. A, M, or F/H power switch - Press to illuminate ON.

The threat legends are now operative (no warm up is required).

2. System self-test - Complete.

Refer to DEF C2 Self-Test procedures.

**UNCONTROLLED
COPY**

**UNCONTROLLED
COPY**

To turn off DEF C2:

1. A, M, and F/H power switches - Off.
System C2 remains on if A, M, or F/H power is ON.

DEF C2 Self-Test

DEF C2 must be tested independently, as self-tests of DEF A2, DEF M, or DEF H do not include DEF C2. The test takes 12 seconds.

To self-test DEF C2:

1. A, M, or F/H power switch - ON illuminated.
2. SYSTEM SELECT switch - C.
The C legend appears in the Go display.
3. TEST switch - Press to illuminate ON.

Check for the following indications:

- a. Test switch ON legend remains illuminated for 12 seconds.
- b. The legend illuminates steady for one second and then begins flashing. The legend illuminates steady concurrently with the flashing legend.
- c. The GO legend in the Go display illuminates immediately and stays illuminated until the SYSTEM SELECT switch is repositioned.

If any of the above indications do not appear, refer to the DEF C2 Malfunction Procedures.

NOTE

Any self-test can be terminated by repositioning the SYSTEM SELECT switch during the test or by pressing the TEST switch again to extinguish ON. However, a self-test of the same system or of another system cannot be started until completion of the original test duration period.

DEF C2 Malfunction Procedures

There is no direct indication of a DEF C2 failure. Indirect indications are the absence of a GO legend in the Go display and/or no illumination of the warning legends during a self-test.

Additionally, a DEF C2 failure might be indicated in a tactical situation by continuous illumination or rapid flashing activity indicator lights on the DEF control panel (in addition to a legend for DEF H) without illumination of the legends. A quick DEF C2 self-test can be initiated for verification. If the legends illuminate, terminate the self-test immediately by repositioning the SYSTEM SELECT switch and continue monitoring the DEF panel.

The only possible method of correcting a DEF C2 failure is recycling the system by simultaneously recycling the A, M, and F/H power switches to off and back to ON.

WARNING

If DEF C2 has failed, and the aircraft is under a threat condition do not recycle DEF A, DEF M, or DEF F/H power switches. DEF A and DEF M are independent of DEF C2 and DEF H can be activated manually in conjunction with the legends.

DEF H SYSTEM

DEF H is a jamming system

*Deleted IAW SR71
SLG 23 Sept 96.*

**UNCONTROLLED
COPY**

**UNCONTROLLED
COPY**

SR-71A-1

SECTION IV

*Data related to SR-71
SCG dated 23 Sept 76.*

DEF H includes a transceiver, two transmitting systems, an interface unit (IU), a data processor, and an evaporative cooler. Radar signals received by the forward centerline receive antenna are sent to the transceiver,

Signals associated with the _____ which are received by an aft centerline antenna, are routed to the DEF H system through a band pass filter and pre-amplifier in the S-bay. The DEF H system then processes _____ these signals if the status switches are in operate (O).

NOTE

The HI band status switch must be in O before the _____ status switch can be set to O.

_____ and provides an output to the AR-1700 recorder of the EIP system. The IU then controls the jamming pulses generated by the _____ transmitting systems. The transmitting systems are designated as low-band _____ and high band coverage). Each consists of

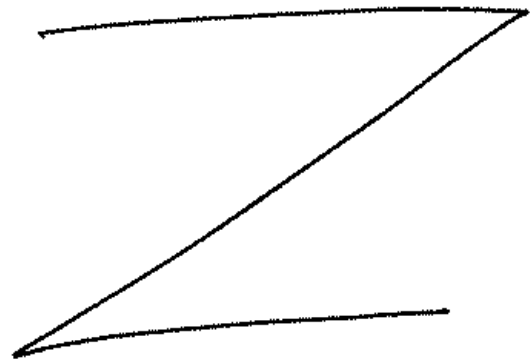

During manual operation, each band can be driven by commands from the DEF control panel to _____ three modes).

During _____ operation, except for system transmit functions, the DEF H operates identically to _____ operation. Upon receiving information from DEF C2, DEF H will transmit predetermined frequencies as determined by the LO and HI Mode selections. The _____ jamming in the _____ state is either computer controlled or predetermined broad band _____ depending on whether _____ is selected. If either of these modes is selected, _____ jamming is _____ in the corresponding band.

_____ The threat recognition characteristics and DEF H transmitted output characteristics are programmed in the computer prior to flight. See Figure 4-41.

DEF H is installed in the forward left bay (K Bay). See Figure 4-38. DEF H operates in conjunction with the DEF C2 receiver system and the EIP AR-1700 recorder. It also supplies transmit, self-test results, mode select, system status, and fault data to the MRS.

**UNCONTROLLED
COPY**

**UNCONTROLLED
COPY**

Electrical power to DEF H is supplied from the left generator ac bus through the 3-phase circuit breaker in the C-bay and from the monitored dc bus through the DEF F circuit breaker on the RSO's right console. See Figure 4-40.

Cooling air is supplied directly to the DEF H unit through an air inlet opening which mates with the airplane cooling air duct during DEF H installation in the aircraft. Air flow is controlled by the left mission bay air shutoff valve. The evaporative cooler acts as a heat sink for coolant fluid after it is heated.

DEF H Threat Warning & Activity Indicators

Threat warning is provided by the DEF H system

Illumination of these legends reflect receipt of radar threats meeting preprogrammed parameters.

LEGEND/RADAR MATRIX

(jamming) is indicated by the continuous illumination of the associated

correspond to the azimuth and elevation antennas for each band and illumination signifies rf power is being radiated.

NOTE

- Due to the low power of jamming, the HI-band legends may not illuminate when rf power is being radiated. Illumination of the legend is a valid indication of jamming.
- DEF H threat warning indicators remain illuminated during jamming

Illumination of DEF H threat warning indicators

jamming has been activated in either high or low band.

The legend illuminates steady when DEF C2 receives a signal. The legend flashes and the legend illuminates steady when DEF C2 receives a signal. If DEF H interprets the threat to be genuine, the Legend will also illuminate. With illumination of the legends, and with operation selected for either low band and/or high band transmitters, jamming begins as evidenced by the low and/or high band legends illuminating.

*Deleted IAW
5721 SCC
23 Sep 90*

**UNCONTROLLED
COPY**

**UNCONTROLLED
COPY**

(when jamming should occur), or a combination thereof. In most cases, a return to normal operation is accomplished by pressing the FAIL RESET switch (hereafter referred to as the RESET switch) after the TEST switch ON legend extinguishes.

NOTE

The DEF FAIL legend on the DEF Warning Panel illuminates whenever a FAIL, HOT or COMP legend is illuminated on the DEF control panel Fail display.

1. Electrical Power Failure

This type of failure affects the and TWT power supplies. It is indicated by illumination of the HI and/or LO and the FAIL legend on the control panel Fail display and the absence of legends under jamming conditions (threat or self-test) for the associated HI and/or LO-band.

Press the RESET switch. If this does not correct the fault and, if time and conditions permit, turn power OFF for 3 minutes, then back ON. The system will come back on in the warm-up mode if the system has completed the cycle-out phase. Then perform the normal operating procedures. If the system comes back on in the standby mode (S), the system did not complete the cycle-out phase, the fault remains, and the power will have to be recycled again.

2.

**UNCONTROLLED
COPY**

Unfaulted transmitter(s) continue to operate normally. This fault is indicated by the system (LO or HI band) legends being extinguished

The control panel FAIL legends blink on momentarily if only one channel is disconnected (either legend extinguished), but illuminate steady if both channels are disconnected

legends extinguished). A disconnect of only one channel is referred to as a disconnect while disconnect of both channels is a complete disconnect.

If either fault occurs, press the RESET switch. If the fault does not clear, return the system to standby, press the RESET switch, and return the system to operate. If the corrective action does not correct the fault, and if time and conditions permit, turn power OFF for 3 minutes, then back ON. The system will come back on in the warm-up mode if the system has completed the cycle-out phase. Then perform the normal operating procedures. If the system comes back on in the standby mode (S), the system did not complete the cycle-out phase. The fault remains, and the power will have to be recycled again.

3. Thermal Failure

This failure is caused by several faults; over/under voltage, high oil pressure, high oil temperature, low oil flow or high temperature in the IU. A thermal fault is indicated by a (LO and HI band) HOT indication on the DEF control panel Fail display and by both systems' legends, if illuminated, extinguishing.

With a HOT indication in either band, both bands return automatically to standby (S) until the fault clears or a manual RESET is performed. If the fault is transient, the system will clear itself, and both systems will return from S to O. With a HOT legend illuminated, DEF H should be turned off if continued operation is not essential. If time permit allow a five to ten-minute cool-down period with power off and the...

**UNCONTROLLED
COPY**

SR-71A-1

SECTION IV

reattempt normal operation. (The coolant pumps continue to operate for three minutes during the cycle-out phase.) In an emergency, the RESET switch may be pressed and jamming will resume after 60 seconds. If the fault has cleared within that time, jamming continues. If the fault is still present after 60 seconds, both systems return to standby (S) and must again be reset manually to resume jamming. If the tactical situation warrants, this action can be repeated as required but may cause permanent damage.

CAUTION

The RESET switch should not be used in training situations to clear a thermal failure. It is reserved for tactical situations.

NOTE

A thermal failure in the IU results in the HOT legend illuminating. This failure cannot be overridden and manual mode must be selected. When the manual mode is selected, the HOT legend extinguishes.

4. Low RF Output Power

If an antenna does not receive adequate power from its transmitter, the associated legend does not illuminate during jamming.

Return the system to standby, press the RESET switch, and return the system to operate. If this does not correct the fault, and if time and conditions permit, turn power OFF for 3 minutes, then back ON. The system will come back on in the warm-up mode if the system has completed the cycle-out phase. Then perform the normal operating procedures. If the system comes back on in the standby mode, the system did not complete the cycle-out phase. The fault

remains, and the power will have to be recycled again. In a tactical situation, do not recycle power if one antenna is jamming. FAIL legends are not associated with this malfunction and it is doubtful that it can be cleared.

5. Computer Failure

A failure which causes the data processor (computer) to cease operation is indicated by HI, LO, and COMP legends illuminating on the DEF control panel Fail display and all automatic operation ceasing.

Press the RESET switch. If this does not correct the fault, and if time and conditions permit, turn power OFF for 3 minutes, then back ON. The system will come back on in the warm-up mode if it has completed the cycle-out phase. Then perform the normal operating procedures. If the system comes back on in the standby mode, the system did not complete the cycle-out phase, the fault remains, and the power will have to be recycled again.

If the failure persists, manual jamming is available and the only warning indications would be the legends.

The computer conducts a diagnostic self-test at system turn-on. If a computer fault occurs, a reset may be attempted. If the fault clears, operation can be continued. If the fault does not clear, manual operation is the only state available.

6. DEF C2 interface Defect

An interface defect between DEF C2 and DEF H could result in DEF H not responding automatically when a signal is received by DEF C2. Since neither system recognizes this failure, FAIL legends would not illuminate. The only indication

**UNCONTROLLED
COPY**

**UNCONTROLLED
COPY**

would be illumination of the legends without corresponding or jamming of the LO and/or HI band. (An legend without an legend would indicate optical guidance.)

If the legends illuminate, but the legend does not illuminate, initiate manual jamming as long as the legends are illuminated.

WARNING

Continuous illumination of the DEF C7 legend, without a corresponding legend, could indicate a

threat and/or interface failure between DEF C2 and DEF H.

DEF M SYSTEM

DEF M is a deceptive repeater jammer ECM system that reacts against

DEF M indications on the DEF control panel are provided to the MRS for postflight analysis. Except for electrical power and cooling requirements, DEF M does not interface with any other aircraft or DEF systems.

The DEF M unit, located on a rack in the D-bay, is ground programmable through the User Data Memory module (UDM). Programs are selected in bands; each band center is programmable in The bands may overlap, be adjacent or non-adjacent, in any combination.

DEF M uses a single antenna and is time-shared between the receive and transmit functions. The antenna is located on the fuselage bottom centerline at FS 315, forward of the viewsight window and is protected by a slightly protruding fiberglass radome.

Electrical power is supplied to DEF M from the essential ac and monitored dc busses through circuit breakers in the C-bay. See Figure 4-42.

Cooling air is supplied to the DEF M unit through an inlet plenum and hose connected to the D-bay cooling air duct. Air flow is from the right mission bay air manifold which is controlled by the right bay air shut-off valve.

DEF M Threat Warning & Activity Indicators

Threat warning indications are provided by the legend on the DEF control panel; the legend on the DEF warning panel. 1 indications are operative in the standby (S) and operate (O) modes.

In standby, the legend may flicker when the received signal strength is near the preset threshold. In operate, the indication will only illuminate in a steady state, indicating a designated threat signal has been received and countermeasures are to be taken. Illumination of the legend indicates the system is responding to the threat. Jamming continues for 5 seconds after a threat is no longer present. The and legends will then extinguish simultaneously.

DEF M Operation

DEF M is turned on and off using the M power switch. Pressing this switch to illuminate ON places the DEF M unit in a three minute warm-up state indicated by illumination of the power switch W legend and the status switch M legend. At completion of warm-up the W extinguish

*Deleted from SR71 SC6
23 Sep 96.*

**UNCONTROLLED
COPY**

SR-71A-1

UNCONTROLLED COPY

SECTION IV

DEF M SYSTEM SIGNAL FLOW

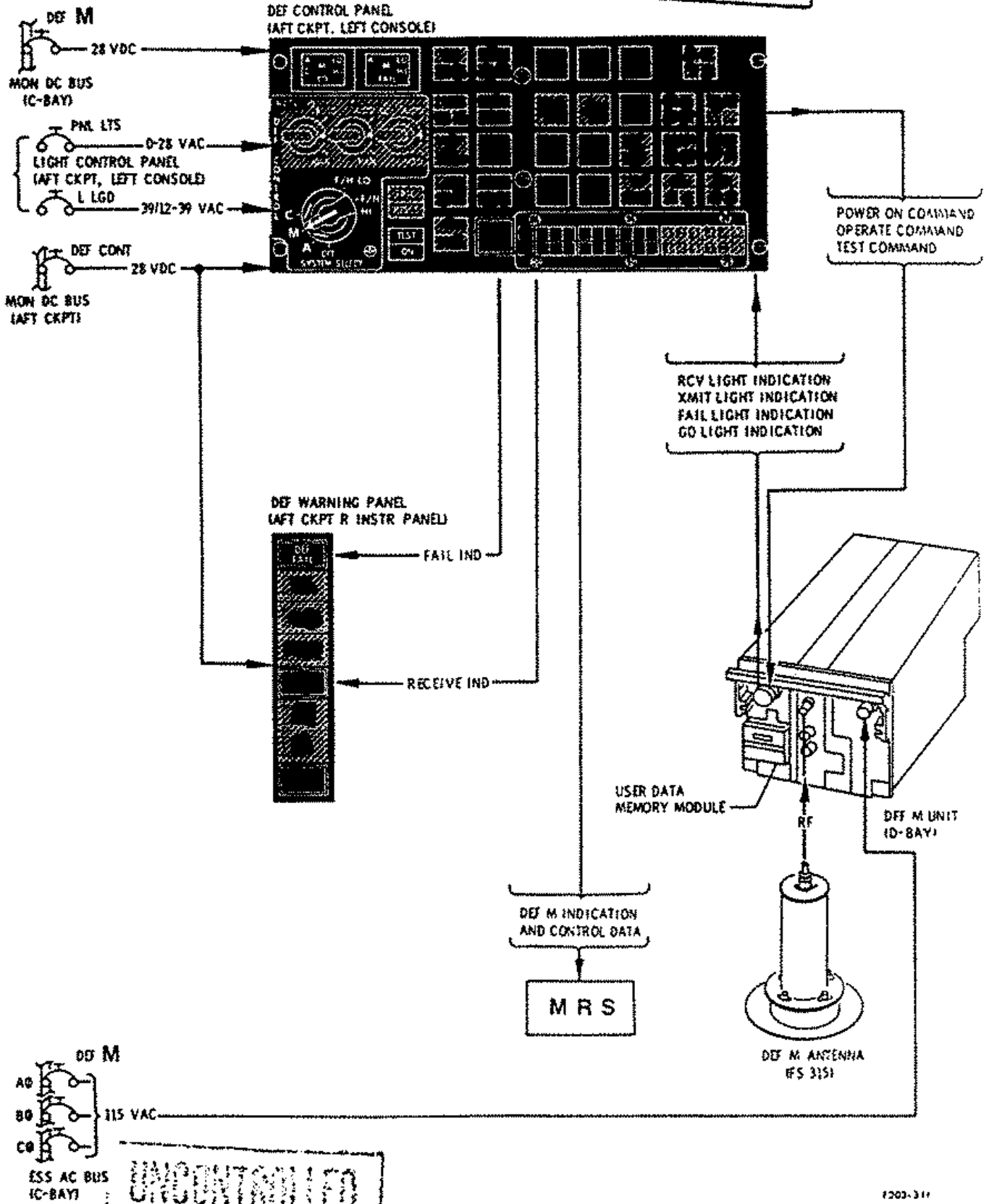

UNCONTROLLED COPY

Figure 4-42

1200-311

and the M status switch S legend illuminates. In standby (S illuminated) DEF M is capable of threat detection and warning but, countermeasures are inhibited until the system is set to operate (O illuminated) by pressing the M status switch.

DEF M Normal Procedures

To turn on DEF M:

1. M power switch - Press on.

ON and W legends illuminate. With SYSTEM SELECT switch set to M the M legend illuminates in the GO display. In approximately 3 minutes the W legend extinguishes and the status switch S (standby) legend illuminates.

NOTE

Threat warning lights are operative.

After warm-up:

2. M status switch - Press to illuminate O.

The S legend extinguishes and the O (operate) legend illuminates. Jamming is automatic in operate.

3. Self-test - Complete.

Refer to DEF M Self-Test.

To return to standby:

1. M status switch - Press to illuminate S.

To turn off DEF M:

Ensure S illuminated before removing power.

1. M power switch - Off (ON extinguished).

NOTE

If immediate system availability is desired maintain DEF M in S mode.

**UNCONTROLLED
COPY**

DEF M Self-Test

Self-test may be accomplished in standby or operate. A self-test in standby can produce a GO indication, but the system jamming capability will not have been tested. Therefore, self-test is normally accomplished in operate.

Self-tests are performed with the SYSTEM SELECT switch set to M. A self-test requires 5 seconds although all checks are completed within the first 1.5 seconds. During self-test in operate a transmission of less than 1 second will occur.

WARNING

Do not perform self-test during air refueling.

NOTE

The self-test cannot be reinitiated until the five seconds have elapsed.

To self-test DEF M:

1. M status switch - O illuminated.
2. SYSTEM SELECT switch - M.
M legend appears in the GO display.
3. TEST switch - Press to illuminate ON.

Check the following indications:

- a. Test ON illuminates immediately and remains for 5 seconds.
- b. The following DEF control panel legends illuminate for 1 second; M XMIT, FAIL/RCV, GO in GO display, and M and FAIL in the FAIL display.
- c. After 1 second, the GO display GO legend remains on until self-test is complete then it and the TEST switch ON legend extinguish.

**UNCONTROLLED
COPY**

**UNCONTROLLED
COPY**

SR-71A-1

SECTION IV

4. SYSTEM SELECT switch - OFF.

GO display M legend extinguishes.

5. M status switch - O or S, as required.

CAUTION

To avoid DEF H damage due to overheating, do not exceed the transmission time periods scheduled for the reliability checks while testing in the manual modes below FL 500.

DEF M Malfunction Procedures

For a FAIL indication attempt to reset DEF M by ensuring the system is in standby and then cycling the power switch off and back on. If the system is off for less than 10 seconds the warm-up period is reduced to 45 seconds.

NOTE

DEF M cannot be reset with the DEF control panel RESET switch.

NOTE

- Any self-test can be terminated while the test is in progress by repositioning the SYSTEM SELECT switch. However, a self-test of the same system or of another system cannot be started until completion of the original test duration period.
- For training missions, perform several self-tests of each system during flight. For operational missions, perform another DEF A2 self-test prior to final descent; whether or not self-test of DEF H will be performed prior to descent varies for operating locations and will be briefed.

DEF SYSTEMS INTERFACE/
RELIABILITY CHECKS

The following tests of systems interface and reliability should be initiated as soon after takeoff as convenient. They should be accomplished before acceleration to supersonic speeds but can be finished after transonic acceleration if required. The checks performed will depend on the actual combination of systems aboard the aircraft. See the respective Self-Test discussions for each DEF system.

WARNING

Due to the rf radiation levels generated by a DEF external transmission, set DEF systems to standby and do not conduct self-test during air refueling.

1. DEF A2 - Self-test.
2. DEF H - Self-test.
3. DEF C2 (With DEF H installed) - Self-test DEF C2 and DEF H interface.

DEF C2 (Without DEF H installed) -Self-test.
4. DEF H - Test the manual transmit modes.
5. DEF M - Self-test.

**UNCONTROLLED
COPY**

SECTION IV

NAVIGATION AND SENSOR CONTROL SYSTEM

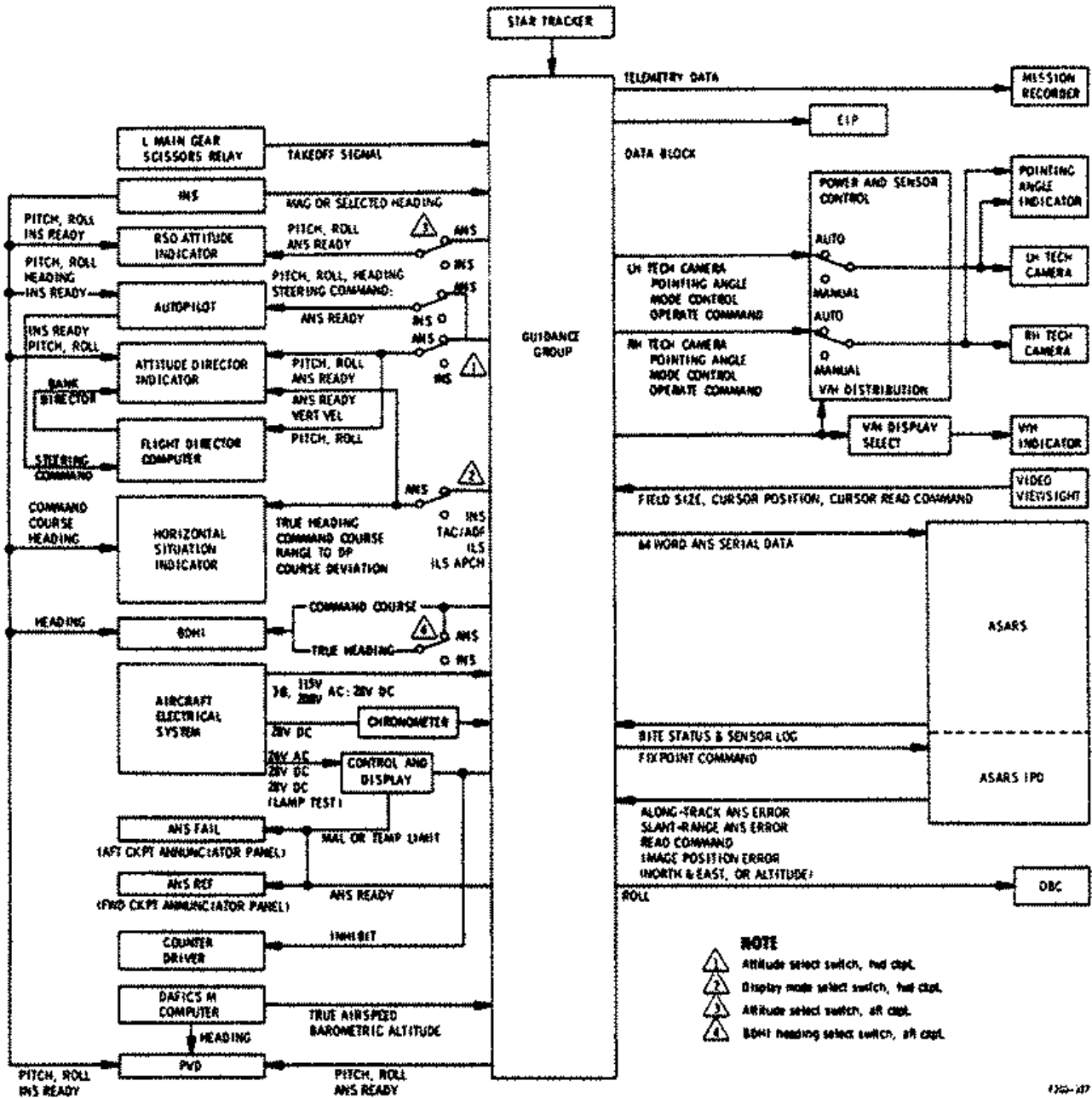

Figure 4-47

of warmup time. A ground hot start can be performed on a system previously aligned and shut down or on a system which has been shut down after operation in the astro inertial or inertial-only mode, provided the aircraft has not been moved. A runway heading alignment is recommended after a rapid alignment or a ground hot start. A heading update may or may not be required.

INERTIAL-ONLY Mode

INERTIAL-ONLY mode, in which only the inertial portion of the astroinertial system is employed, is recommended when the star-tracking capability of the navigation system is impaired. In this mode, navigation errors are unbounded.

AIRSTART Mode

The airspeed-damped, astro inertial (airstart) mode, which uses both the inertial platform and star tracker, is intended for: (1) scramble-initiated flights when the system is not prepared for a ground hot start, and (2) restart in flight. In this mode, errors can be large at first but should damp down with time to the values in Figure 4-48. Dead reckoning data are used for present position until three different stars have been acquired (steady illumination of the star ON light). Star acquisition is critical for accurate navigation.

Dead Reckon Mode (DR)

If the ANS inertial platform fails, navigation may continue using dead reckoning. In DEAD RECKON mode the ANS computer navigates using heading from the INS, true airspeed from the DAFICS (M computer) and inflight winds filled by the RSO. Position error increases proportional to errors in these inputs.

SYSTEM ERRORS

Error values in Figure 4-48 are based on the high altitude flight profiles. Abnormal flight profiles (low-altitude, race-track, touch-and-go, etc.) may result in errors in excess of the listed values. The error values listed are

probable radial errors (CEP's); therefore, under normal system operation, the listed errors will be exceeded about half the time. When star tracking is lost, a residual position error may develop that will not be totally eliminated when star tracking resumes. It might take as many as 3 navigation position updates (depending on Schuler cycle period) and a steady C star light to eliminate the total residual error.

SYSTEM COMPONENTS

The navigation system has three major assemblies: the control and display panel, the portable chronometer, and the guidance group. The control and display panel (Figure 4-49), located on the aft cockpit right console, is used to activate the system, select modes of operation, insert and monitor navigational data, modify the mission flight plan, and observe operating status.

A portable chronometer, in the aft cockpit supplies Greenwich Mean Time (GMT) (accurate to one-hundredth of a second) and the Julian date to establish the orientation of the Earth in inertial space for astro-inertial operations. The chronometer is set in the base shop, using a time standard set up to receive WWV time signals. Day can be set up to 511, thus allowing use of the computer star catalog into the next calendar year. A fully-charged, self-contained battery permits timekeeping for up to 24 hours without other power. Chronometer outputs are enabled only when aircraft power is applied. There is a GO, NO-GO indicator on the chronometer. GO indicates that either external or battery power is available and that the chronometer is operable, but does not indicate that the correct day and time is set. NO-GO indicates that chronometer outputs are unreliable.

The guidance group contains the electronic and optical-mechanical equipment for navigation and avionics subsystems control. The guidance group is mounted in the fuselage aft of the rear cockpit to provide an upward 78-degree cone of vision for the star-tracking telescope. The axis of the cone is vertical

SECTION IV

NAVIGATION MODE PROBABLE RADIAL ERROR

NAVIGATION MODE	ALIGNMENT METHOD			
	GRD HOT START	RAPID	AIRSTART	GYROCOMPASS
ASTRO INERTIAL ⁴ ³	1.0 nmi	0.3 nmi (up to 10 hrs) ⁵	—	0.3 nmi (up to 10 hrs)
INERTIAL ONLY (with fixpoints every hour) ¹	5.0 nmi/hr	2 nmi/hr 1.28 nmi	—	2 nmi/hr 1.28 nmi
AIRSTART (without fixpoints) (with 2 fixpoints in first hr 20±5 min apart) ¹	—	—	after 2 hrs: 1.75 nmi after 1 hr: 1.25 nmi	
DEAD RECKONING ²	55 nmi/hr (Depends on INS and DAFICS accuracy)			

¹ Using fixpoints ascertained to 1-nmi accuracy

² No alignment required - Accuracy only as good as inputs (W/V, Hdg, MV, TAS)

³ Without continuous star tracking, errors approaching inertial operation can develop

⁴ With current accelerometer null bias calibration

⁵ With heading entry accurate to 0.1 degree

F203-9211

Figure 4-48

when the aircraft pitch angle is 7-1/2 degrees. The guidance group includes an inertially stabilized platform and associated electronic and electromechanical components required to control (1) its attitude, (2) a star-tracking telescope, and (3) the electronic and electromechanical components for pointing, servo-controlling, and discrimination of telescope photo-detections. A digital computer computes auto-navigation, guidance and avionics control, and maintains a continuously updated account of navigational status and coordinate values. The computer also stores instrument and mathematical coefficients, predetermined data references that define stars, and the mission flight plan. The computer initiates and evaluates self-tests periodically throughout the operating interval. Software corrections to the star data are provided for: (1) the shock wave over the window that refracts the star light and (2) pressure and temperature gradients (differentials) acting on the window causing optical lens effects.

NAVIGATION CONTROL AND DISPLAY PANEL (NCD)

The NCD (Figure 4-49) on the aft cockpit right console controls the ANS.

NOTE

The positions of the ANS controls and the last pushbutton operations are recorded once each 0.832 seconds by the MRS. Events can be marked by using the ANS keyboard.

MODE Switch

The rotary MODE switch has seven positions:

- OFF Power is off except illumination power and chronometer power.
- WARM UP Power to temperature control circuitry and the computer.

NAVIGATION CONTROL AND DISPLAY PANEL

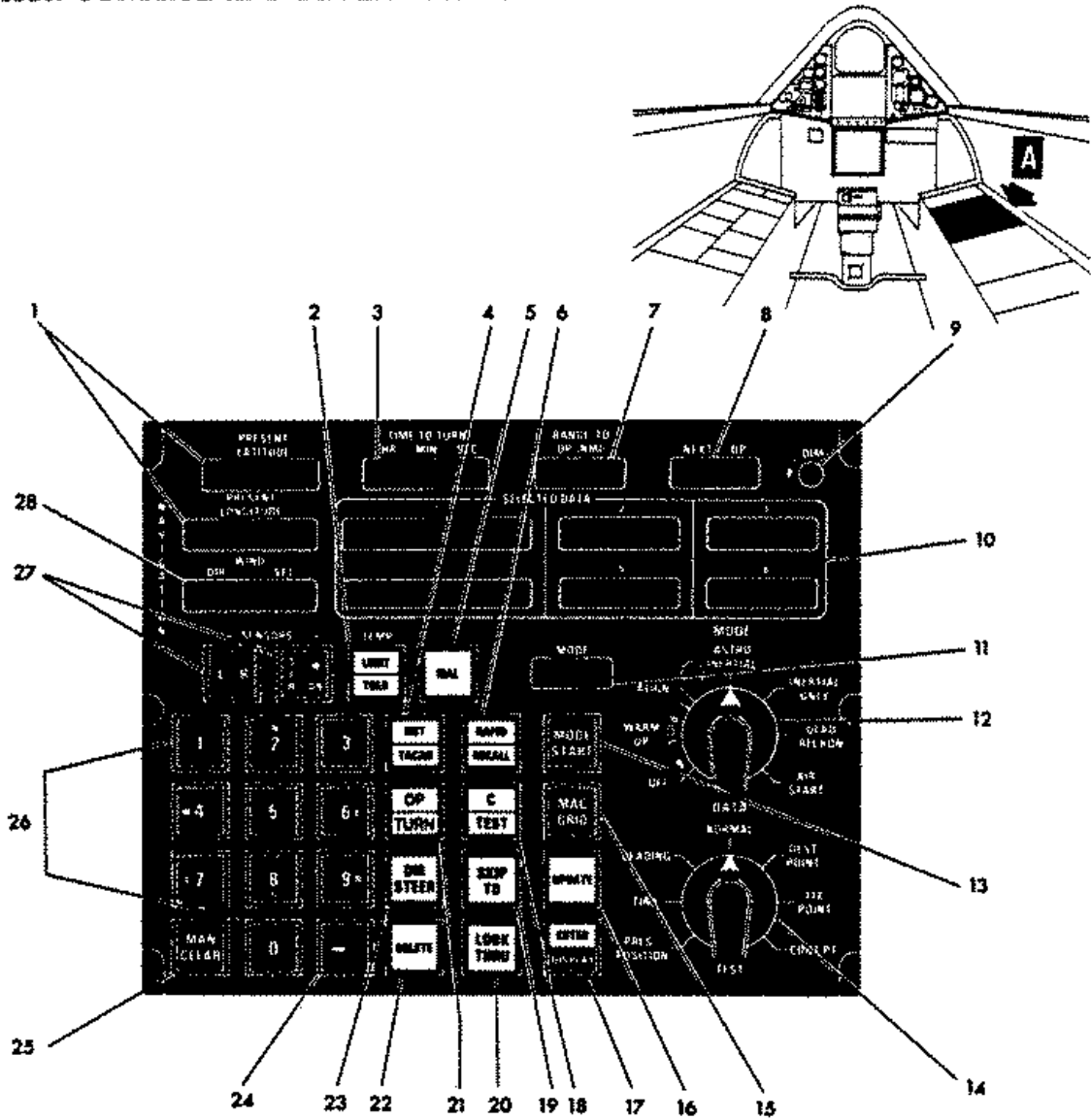

- | | |
|-------------------------------------|---|
| 1 PRESENT POSITION WINDOWS | 15 MAG/GRID SWITCH |
| 2 TEMPERATURE MONITOR LIGHTS | 16 UPDATE SWITCH |
| 3 TIME-TO-TURN WINDOW | 17 ENTER/DISPLAY SWITCH |
| 4 HOT/TAGAN SWITCH | 18 C/TEST SWITCH |
| 5 MALFUNCTION LIGHT | 19 SKIP TO SWITCH |
| 6 RAPID/RECALL SWITCH | 20 LOOK THRU SWITCH |
| 7 RANGE TO DESTINATION POINT WINDOW | 21 DP/TURN SWITCH |
| 8 NEXT DESTINATION POINT WINDOW | 22 DELETE SWITCH |
| 9 DIM SWITCH | 23 DIRECT STEER SWITCH |
| 10 SELECTED DATA WINDOWS | 24 BACK SPACE SWITCH |
| 11 MODE WINDOW | 25 MANUAL CLEAR SWITCH |
| 12 MODE SWITCH | 26 MANUAL KEYBOARD AND POSITION PREFIX REFERENCE SWITCHES |
| 13 MODE START SWITCH | 27 SENSOR OPERATION INDICATOR LIGHTS |
| 14 DATA SWITCH | 28 WIND DIRECTION AND WIND VELOCITY WINDOWS |

F203-748(c)

Figure 4-49

SECTION IV

The following five modes are called "operate" modes, since power is applied to the entire ANS. Operation begins only after the MODE START, RAPID, or HOT switch is pressed.

ALIGN	Used on the ground to remain in fine alignment or for ground alignment correct procedure.
ASTRO INERTIAL	Selects astro-inertial navigation.
INERTIAL ONLY	Selects inertial-only navigation.
DEAD RECKON	Selects dead-reckon navigation.
AIRSTART	Used to perform a cold airstart (in-flight alignment) which results in airspeed damped, astro inertial navigation.

The MODE switch has a detent that prevents switching to OFF or WARM UP from an "operate" mode without lifting the switch. A detent prevents moving the switch clockwise past AIRSTART.

MODE START Switch

After power on, pressing MODE START initiates a gyrocompass or cold airstart alignment. After alignment, pressing the self-illuminated switch enables the mode selected by the MODE and MAG/GRID switches.

MAG/GRID Switch

The MAG/Grid switch is an alternate-action switch. Either the MAG or GRID half of the switch is lighted at all times. The ANS computer interrogates this switch each time the MODE START switch is pressed.

Set the switch to MAG. There is no useable grid heading available to either cockpit with the SKN-2417 INS in normal operation. The ANS computer interprets the INS heading input as MAG heading and makes appropriate computations to provide a true heading value for the dead-reckoning reference frame.

DATA Switch

The rotary DATA switch is used to select a panel fill, update, display, or mission modification procedure. The position of the switch determines the first character (always alphabetical) of the SELECTED DATA (SD) window that expects data. The eight DATA switch positions are PRES POSITION, TIME, HEADING, NORMAL, DEST POINT, FIX POINT, CONT PT, and TEST.

Keyboard Switches

The ten numerical keyboard switches, labeled 0 through 9, are used to enter data into the ANS or to command display of ANS data.

MAN CLEAR Switch

Used to clear the SELECTED DATA windows if an error is made during a panel-initiated procedure, and to not use an ANS position, altitude, or runway-heading alignment update. It is also used in the ANS malfunction routines.

ARROW (Backspace) Switch

Used to erase filled data one digit at a time in reverse order prior to actuating an action switch such as ENTER.

LOOK THRU Switch

Used to display data pertaining to the destination point (DP) after the DP now approaching.

SKIP TO Switch

Used to command the ANS to skip to a selected DP from the current next DP.

RAPID/RECALL Switch

Used to select rapid ground alignment or to recall data for display of the previously panel-filled TACAN point.

DELETE Switch

Used to delete a particular panel-filled

DATA IN SELECTED DATA WINDOWS FOR PANEL ROUTINES (TAPE 13)

PANEL ROUTINE SEL- ECTED DATA WINDOW	DIRECT STICR	SKIP TO DP	DELETE FP, CP, DP	ADD OR REPLACE FP, CP, DP	NORMAL DISPLAY	DISPLAY NEXT FP, CP, DP	DISPLAY SELECTED FP, CP, DP	DISPLAY HEADING	DISPLAY DAY OF YEAR/STAR DATA	DISPLAY PRESENT POSITION	DISPLAY LOOK THRU	DISPLAY TAPE NUMBERS/ TEST
1	Latitude if new point is filled, NUS XX' XX, XX'			Latitude NUS XX' XX, XX'	GMT in XX hours, XX mins, XX seconds	Latitude, NUS XX' XX, XX'	Latitude NUS XX' XX, XX'	Velocity vector heading VAXX XX, X'	GMT in XX hours, XX mins, XX seconds	Latitude of alternate present position frame, NUS XX' XX, XX'	Latitude of DP + 1 NUS XX' XX, XX'	F - STIMACC T - Tape M - Mod C - Corr
2					True airspeed in knots DXXXX	Range to DP RXXX, X nmi slant range R TACAN EP SXXX, X nmi slant range along track range to CP/ FP AXXX, X nmi	Great circle range for CP, DP, FP AXXX, X nmi slant range R TACAN FP SXXX, X nmi	Grm heading DXXX, X'	Star number SXX		Along track range to DP + 1 R XXXX nmi	Mission tape No. OXXX O * * or A BCD Z or a thru e
3				Terrain elevation in hundreds of feet for CP's or FP's XXX, Turn radius in nmi for DP's, XXXX, X nmi	Heel FP No. FRT XXXX	Turn radius to DP XXXX nmi terrain elev for CP, FP, hundreds of feet XXX	Turn radius R DP XXXX nmi terrain elev for CP, FP, hundreds of feet EXXX	Chart convergence factor CX, XXX	Scan Rate Code R X	Nav altitude in hundreds of feet, AXXX	Turn radius of DP + 1 R XXX nmi	General Instrument constants tape No. CXXX
4				Longitude EW XXX' XX, XX'	Aircraft cross track position, nautical miles LR XXX, X	Longitude EW XXX' XX, XX'	Longitude EW XXX' XX, XX'	Aircraft true heading TXXX' XX, X'	Time in this star search T XXX:XX min : sec	Longitude of alternate present position frame, EW XXX' XX, XX'	Longitude of DP + 1 EW XXX' XX, XX'	YY1 Normalt YY2 Efloatr Where YY-year
5				LR XX, 0 SR code or EROD, 0 for CP, FP or EW XX, X', mag var for TACAN FP's	Aircraft Ground Speed in Knots GXXX	Relative bearing to DP, CP, FP LR XXX, X' TACAN bearing to TACAN FP BXXX, X'	Relative bearing to point LR XXX, X' Magnetic bearing if TACAN FP BXXX, X'	Magnetic variation EW XXX, X'	Number of stars acquired AXXXX	True angle in degrees, (if positive) SXX, X'	Time to DP + 1 DXXX, X min	YY1 Normalt YY2 Efloatr Where YY-year
6				Point ID Code D XXXX C/CXXXX F/FXXXX	Heel CP No. C/CXXXX	ID code of next point, D XXXX C/CXXXX F/FXXXX	Selectd point ID code D XXXX C/CXXXX F/FXXXX	Magnetic heading MXXX'	Julian day of year DXXX (1-511)		DP + 1 ID No. D XXXX	Test 0 indication T 0

Figure 4-50 (Sheet 2 of 3)

Star ON Indicator Light

The light indicates the status of star tracking as described in the Computer Program section. Steady illumination of the light indicates that a minimum of two different stars have been tracked within the last 5 minutes.

MODE Window

The MODE window displays a legend which shows the operating phase of the ANS. The MODE window also displays an error message in the event of an operator error and may indicate recommended action in case of system malfunction. The malfunction indications are described in the Malfunction Indicator and the ANS MALFUNCTION PROCEDURES paragraphs. The MODE window indications are:

<u>Indication</u>	<u>Operating Phase</u>	<u>Definition</u>
C/A	COARSE ALIGN	Initial phase of ground or air start alignment.
F/A	FINE ALIGN	Final phase ground alignment.
RES	RE-START	Second phase of air-start or ground hot start alignment.
A-I	ASTRO INERTIAL	Astro inertial navigation.
I/O	INERTIAL ONLY	Inertial-only navigation.
D/R	DEAD RECKON	Dead-reckon navigation.
ENT		Coarse align complete. Enter present position or heading.
ERR		An operator error in panel operation has been committed.
ENC		Encoding failure.

DP*

Mission tape program sequence in error.

BLANK WARM UP Mode switch is in WARM UP and 28 volts dc is present.

Temperature Limit/Tolerance Indicator

The temperature limit and tolerance indicator, labeled TEMP LIMIT/TOLR is a split-function indicator which displays monitored cooling air flow and system internal temperatures. The top half of the indicator is red with the LIMIT legend visible when lighted. The bottom half of the indicator is amber, with the TOLR legend (tolerance) visible when lighted. (Refer to ANS MALFUNCTION PROCEDURES.)

Malfunction Indicator

The ANS malfunction indicator, labeled MAL, is a red panel light that can be off, on-steady, or on-flashing. Generally, the MAL light is off during normal operation, on-steady when the ANS is in the WARM UP mode, and on-flashing when a system self test has failed. (Refer to ANS MALFUNCTION PROCEDURES for detailed description.)

COMPUTER PROGRAM

The basic instructions and constants for computer operation are contained in the main program tape which is loaded into the computer permanent memory. The computer program is loaded in two parts, a basic main program tape and a correction tape (if needed). In addition, a general instrument constant (GIC) tape, star catalog (SYY1, SYY2) tape, and mission tape are loaded. Each ASTRO INERTIAL (A-I) unit has its own GIC tape which defines gyro, accelerometer, resolver, etc. parameters unique to the respective A-I unit. Annual revisions are made to the star catalog tapes.

SECTION IV

STAR DATA USAGE

STAR	DEFINITION	DATA USAGE
A	First star tracked after a hot or cold airstart, ground hot start, or after changing from A-I to I/O and back to the A-I mode.	Computational triad and platform are corrected but present position is not changed, so there is no perturbation in latitude, longitude, or auto nav.
B	Second star tracked after an A star, or First star tracked after a ground alignment.	Computational triad and platform are corrected and now in coincidence. Latitude, longitude and auto nav adjustments occur. Computational triad and platform are corrected but present position is not changed, so there is no perturbation in latitude, longitude, or auto nav.
C	First and subsequent star tracked after B star.	Platform and computational triad are corrected. Auto-Nav transients are allowed on first star C but suppressed on subsequent ones until a bank angle exceeds 5° or position fix inserted

Figure 4-51

Astro Inertial Navigation

The ANS operates in typical inertial navigation fashion. Outputs from two 2-axis gyros drive the platform gimbals to isolate three orthogonally mounted accelerometers from changes in aircraft attitude. The gyros and accelerometers are mounted on the platform's azimuth gimbal (stable element). The accelerometer outputs are components of aircraft velocity change. If the azimuth gimbal is not kept level, the accelerometers also measure a component of acceleration due to gravity and position errors are produced.

In INERTIAL ONLY, the computer uses the accelerometer outputs to calculate aircraft velocity and change in position, and gyro torquing rates. The gyro torquing rates (signals proportional to aircraft velocity plus earth's rate) are applied to the gyros to maintain the azimuth gimbal (and thus the accelerometers) level with respect to the earth. The success of inertial navigation is due to the fact that any system error eventually causes the accelerometers to go

off level and measure a component of gravity which introduces an error that tends to cancel the original error. For example, if an accelerometer develops a null shift that appears to be an aircraft acceleration to the north, the platform will be torqued to keep up with the apparent aircraft motion over the earth's surface. Thus if the platform were level, it becomes tipped off level resulting in accelerometer measurement of gravity which looks like aircraft acceleration to the south. This characteristic of inertial systems is called Schuler tuning.

The star tracking function improves knowledge of accelerometer orientation in azimuth and eliminates the effects of gyro drift. Star search is initiated when astro-inertial mode is selected after completion of alignment. Selection of the star is made by the computer as a function of latitude, longitude, day of year, time of day, aircraft pitch and roll, and location of the sun. Aircraft pitch and roll determine the orientation of the star tracker window. For a given latitude, longitude, time of day and year, a particular star should be at a particular azimuth and elevation. If

the star tracker measurements show that the star is not at the expected azimuth and elevation, there is an error in computed latitude and longitude and/or an error in platform orientation. Since the telescope is mounted on the platform, the star tracker measures the angular difference between the physical triad formed by the platform axes and the computational triad formed by the vertical through the computed position and the calculated orientation of the platform in azimuth. Thus the system cannot directly distinguish between a computed position error and a platform orientation error but, based on statistical probabilities determined by prestored error models and flight dynamics preceding the measurement, (as modeled by a Kalman filter, described later) it will attempt to optimally adjust the various navigational parameters.

To aid in describing star tracker logic, stars are given arbitrary labels depending on if they are the first, second, or third star tracked after the beginning of an operation. These are listed in Figure 4-51 with definitions and a summary of the usage of star tracker measured errors. In all cases, the end result of tracking two different stars is to align the computational triad with the platform triad or vice versa. A single star cannot be used to correct all errors since errors about the axis from the platform through that star are not measured. After the initial two stars are acquired, the normal interval between loss of track from one star to tracking the next star is about 30 seconds at altitude. Since the platform is almost continually brought into alignment with the computational triad, gyro errors have an almost negligible effect. The predominant ANS errors are those due to gyro drift that develop before stars are acquired and when star tracking is interrupted such as during aerial refueling. The star tracking data is used to update computed values of gyro drift to minimize error growth during any subsequent lapses in star tracking.

Star selection, tracker scan rate, and search patterns depend on many factors and are all under computer control. The computer selects a star by going through the star catalog which is arranged in order of

decreasing star brightness until it finds a star that is within the window aperture, not within 10° of zenith (not within 5° of zenith for trainer aircraft), and not within $12\text{-}1/2^\circ$ of the sun. The tracker telescope is commanded to search for the selected star using a variable sized pattern which is symmetrical about the computed star position.

The star search pattern is an expanding rectangular spiral which starts at the side of the pattern and then passes across the computed star position. See Figure 4-52. Maximum A star pattern size is a function of search rate so that all A star searches are completed within 23 minutes.

If the star is detected during this search, confirmation and reconfirmation patterns are made. If these are successful, the star is considered tracked, and elevation and azimuth errors are determined by the star actual position relative to its computed position. Search and track operations are discontinued if the star moves out of the window, the sky is too bright, or a position update is performed. The computer then goes to the next brightest star available, except that when a position update is performed, star search begins at the top of the star list (brightest star).

There are four scan rates which can be used in star search. Scan rate depends on star magnitude and sky brightness. The fastest is used on a bright star in a dim background while the slowest is used on a dim star in a bright background.

The search patterns are chosen as a function of the type of alignment and whether an A, B, or C star is being searched. See Figure 4-52. This table also lists the star ON light activity during star tracking operations.

Star Tracking Techniques

The star ON light provides the RSO with a guide for actions (listed in Figure 4-53) to optimize star tracking. Star tracking is automatic but the operator can assist the system in overcoming conditions such as overcasts, changes of sky background brightness, long

periods of ground time after system initialization to A-I mode, refueling, and periods when tracking is not being accomplished. The operator should attempt to commence tracking stars as soon as possible to prevent or eliminate position error growth.

Improving Star Tracker Scan Rates

The ANS uses different scan rates for the star tracker depending upon the lightness of the sky background around the computed star position. This sampling of background conditions is accomplished automatically prior to beginning each star search. The time it takes the ANS to acquire a star depends on the magnitude of ANS errors. In extreme cases approximately twenty minutes could be required to acquire an A star.

An active (optimum signal-to-noise) filter to the ANS increases the probability of star detection, improves the accuracy of angle measurement, reduces the time devoted to detection and tracking of each star, and increases position and heading accuracy.

By using position fixes or remote updates, the RSO can reinitialize star search at the top of the star list (brightest star). This provides a new sky background lightness measurement and a change in scan rate if sky background lightness has changed. The RSO should use this procedure when there is a noticeable improvement in background conditions and the star ON light is not illuminated.

The RSO should periodically note the star tracking performance as indicated by the star light and star data in the Time display. If star tracking performance is less than expected (intermittent or no star light) for the existing sky conditions, the RSO should display day of year and note star number and scan rate. He should perform a zero remote update or command A, B, C Star Search to select the brightest star available (indicated by a number equal to or less than that previously indicated in SELECTED DATA window 2). This action will match the scan rate to the current sky background condition. A slower scan rate than that previously observed indicates less than optimum sky

**CREW ACTIONS TO OPTIMIZE
STAR TRACKING**

CONDITION	ACTION
Search underway for A or B star.	Maintain straight and level flight.
Star ON light out.	Make maximum number of position checks.
Star ON light out after entering a good sky situation.	Restart star search by using zero remote update procedure.
Star ON light out more than 15 minutes after zero remote update procedure has been performed and good sky conditions prevail throughout.	Command star A tracking by changing mode to INERTIAL ONLY, then change back to ASTRO INERTIAL to increase search pattern size.
Preflight in hangar.	Select INERTIAL ONLY to terminate fine alignment. Select ASTRO INERTIAL after clearing hangar or cloud cover.

Figure 4-53

background conditions. If a star is not acquired, a repeat of these routines when the sky background improves could increase the scan rate thus improving the probability of star acquisition. The scan rates are selected by the computer based on sky background measurements in the vicinity of the star. There are four scan rates available and the one in current use is indicated in SELECTED DATA window 3 as a code R1 (1250), R2 (703), R3 (395) or R4 (222) (arc sec/sec) when using the Time display routine. A dark sky background increases the likelihood of tracking stars and induces a fast scan rate. Conversely, a bright sky background decreases the likelihood of tracking stars and induces a slow scan rate.

SECTION IV

An example of when this procedure could assist star acquisition is: the system is put in A-I mode after completing ground alignment with haze or thin cirrus clouds; after takeoff and leveloff at 25,000 feet, the star ON indicator is not illuminated but the aircraft is now above all haze and cirrus. A zero remote update routine should cause the system to select a faster scan rate as a result of the darker sky background. In most cases, this will speed up star acquisition.

Commanding A and B Mode Stars

If a preflight alignment is performed while under cover, such as in a hangar, select the INERTIAL ONLY mode at the completion of fine alignment and remain in INERTIAL ONLY until clear of the covered area. This prevents false star acquisitions due to ceiling lights, etc. In this case the first star tracked after selecting ASTRO INERTIAL will be a B mode star.

The nominal error growth of the ANS in INERTIAL ONLY is based on pure inertial operation; that is, MODE in INERTIAL ONLY, disabling the tracker from star searching. The tracker slewing on top of the platform in search operation can induce further position error growth. Because of this, the operator should avoid leaving the ANS in the ASTRO INERTIAL mode when star tracking is not expected for 25 minutes or longer. Put the system in INERTIAL ONLY mode when star tracking is lost or is not expected for at least 25 minutes (e.g. during overcast conditions or operation behind a tanker.) Once INERTIAL ONLY has been selected, operation in this mode should be continued until suitable tracking conditions are encountered.

Above 60,000 feet, with nominal star availability and sun angle, the crew can expect A/B mode star acquisition in a few minutes after returning to the ASTRO INERTIAL mode.

NOTE

- Return the ANS to INERTIAL ONLY mode prior to entering a critical sensor "take" area if the star ON indicator has not indicated A/B star acquisition. This will inhibit A/B star updates which would cause auto nav roll transients.
- Although a star light generally indicates a bounded error of less than 1 nm, greater errors are possible. Computer and/or chronometer malfunctions have resulted in the star light being on when position error exceeded 10 miles.

Kalman Filter

The system employs a Kalman filter to optimally incorporate measurements from the star tracker, DAFICS M computer, and fixpoints to correct inertial system errors. The filter continually estimates the error state of 16 parameters:

1. Platform azimuth
2. Platform tilt axis 2
3. Platform tilt axis 3
4. Position error axis 2
5. Position error axis 3
6. Velocity error axis 2
7. Velocity error axis 3
8. Azimuth gyro drift rate
9. 2 axis gyro drift rate
10. 3 axis gyro drift rate
11. 2 axis accelerometer bias
12. 3 axis accelerometer bias
13. Telescope elevation bias
14. True airspeed scale factor
15. Axis 2 Wind
16. Axis 3 Wind

Each of these parameters has a calculated error probability which is initialized as a

function of the type of alignment accomplished. During a ground alignment system position is monitored to detect deviations from the entered coordinates. These deviations are fed as measurements to the filter which utilizes them to refine the first ten listed parameters. When star measurements are obtained, the first thirteen parameters are refined, and when airborne, all sixteen elements are estimated and continually refined. Because of wind variability and the accuracy (+30 knots) of True Air Speed, the airspeed measurement has essentially zero influence on the first thirteen parameters except in the case of a cold and hot airstart. When fixpoint measurements are inserted by the operator, the filter adjusts the 16 parameters according to the ratio of their current estimated error state to the programmed accuracy of the fixpoint device (.05 nm for ASARS, .5 nm, for Viewsight, and 1.0 nm for TACAN). The system incorporates 100 percent of a fixpoint if the correction is more than 5.0 nm.

Dead Reckoning

Dead reckoning is performed simultaneously and separately from inertial navigation. During normal operation in ASTRO INERTIAL or INERTIAL ONLY, the dead reckoning latitude and longitude do not appear to the RSO unless the display Present Position routine is performed. However, prior to continuous star tracking in a cold or hot air start, or when DEAD RECKON is selected, dead reckon data is used as the source of present position and heading for all displays, great circle navigation and guidance, and sensor control. DEAD RECKON is the only mode in which present position can be entered after navigation is started; this may be done as often as desired. When DEAD RECKON is selected, the ANS generates all its normal outputs and continues astroinertial or inertial only navigation so that the DEAD RECKON mode can be selected for training while permitting return to ASTRO INERTIAL or INERTIAL ONLY modes. In normal operation, when dead reckon data is not used for ANS outputs, the dead reckoned latitude, longitude, and difference between INS heading and ANS true heading (magnetic

variation), if applicable, are updated every four minutes using inertial data.

Dead reckoning is the process of computing change in position using heading, speed, and elapsed time. True airspeed from DAFICS (M computer) is used with RSO entered values of wind speed and direction to approximate ground speed. Heading is provided from the INS and is magnetic heading except that ANS inertial heading is used following coarse alignment in a hot or cold air start.

When INS mag heading is being used, the RSO must periodically fill local magnetic variation so that computed true heading will have minimum error. When dead reckon data is not being used, magnetic variation need not be filled since the ANS itself computes a new magnetic variation every four minutes.

MISSION TAPE PROGRAM

The mission profile is defined in terms of destination points (DP), control points (CP), and fix points (FP), and the sensor operations associated with these points. Destination points delineate the prescribed mission track; they are intersections of the intended great-circle legs. Control points and fix points permit automatic activation of imaging sensors, and fix points define preferred navigational references. The mission plan is loaded into the computer memory on a mission tape prior to preflight operations. The mission tape can be programmed to hold up to 256 DP, 256 FP, and 1023 CP (1535 total). Additional temporary memory is provided for 40 point modification operations, known as the "40-List". The modifications may be performed using the Control and Display panel anytime power is supplied to the panel. Up to 40 add and/or replace operations and unlimited skip-to operations, are provided. In addition, there are special Anytime and Opportunity fix point procedures which do not use the 40-List. The mission tape may include a primary flight plan with one or more alternate routes that the crew may elect to follow by exercising the skip-to, direct steer, or track leg update options. The add and replace options of the 40-List permit additional

SECTION IV

alternate paths to be formulated, and allow last-minute changes to sensor activity on programmed legs.

The data loaded into specified cells of the computer memory are identified by function and order of use in the mission plan (D00003, C00007, F00021, etc.). Each point is further defined by its coordinates, its sensor-usage, applicable pointing parameters, and reference to the next consecutive point or points. The destination points reference the next point of all three classes.

Great-Circle Steering

The mission path is a sequence of great-circle legs computed on the basis of DP coordinates. The ANS supplies a steering (bank angle) command to the autopilot in all ANS navigation modes but it is usable only when all requirements for a "nav-ready" condition are present. In the autopilot AUTO-NAV mode, bank angle is commanded by the ANS to automatically guide the aircraft onto and along the preprogrammed flight path. The bank angle steering command is computed from aircraft cross-track position and velocity relative to the desired course. If the planner has scheduled a bank angle of 35° or less, the ANS will not command a bank greater than 35°, even if a higher bank is required to keep the aircraft on course. If the turn is planned above 35° (up to 42°) the ANS will command up to 45° to keep the aircraft on course.

If the AUTO NAV mode is engaged when the aircraft is considerably off track, the ANS will steer towards the desired track at a 30° intercept angle. Depending on current groundspeed, the ANS will compute where to initiate a turn to discontinue the intercept course and smoothly fair onto track. During supersonic cruise this point is approximately 20 nm off course.

Once on course, the aircraft should usually be within 300 feet of the commanded course, except in turns. Actual position of the track is dependent on ANS navigation accuracy.

ANS Steering Turn Modes

The mission planner can choose one of two different turn modes at each DP. These modes determine where the turn start to the next great circle leg will occur and the amount of bank angle commanded during the turn.

Auto-Range-To-Turn

The system computes the turn radius based on a 32° bank angle and the groundspeed at the start turn point. Once the turn is initiated, it is identical to the turn described in the Fixed-Range-To-Turn paragraphs.

Auto-Range-To-Turn should be used for subsonic turns to prevent high bank angles at heavy weights. Current groundspeed and the heading change from present course to next are used to compute and initiate an automatic turn (termed by the mission planners as Turn Start Automatic, or TSA). The TSA point varies since it depends on groundspeed. If actual groundspeed is different from planned groundspeed, the TSA will not occur where planned and the aircraft will not follow the turn line depicted on the strip map. However, if there are no other disturbances, the aircraft should make the turn at a 32° bank angle.

Fixed-Range-To-Turn

Fixed-Range-To-Turn is used by the mission planners for turns that indicate critical sensor legs and turns where strict adherence to the planned turn line is required. In this mode, the mission planner specifies a constant turn radius at a particular DP. The TSA point is a fixed distance plus a variable distance from the DP. The fixed distance is determined by the programmed turn radius and the change in course; it would be equal to turn radius on a 90° turn. The variable distance ranges from 0 to 4.5 nm, depending on groundspeed, and compensates for the distance required to roll into the turn. During the turn, commanded bank angle is the sum of two components. One component is the nominal bank required to achieve the programmed turn radius at the current

TYPICAL DESTINATION-POINT PLAN

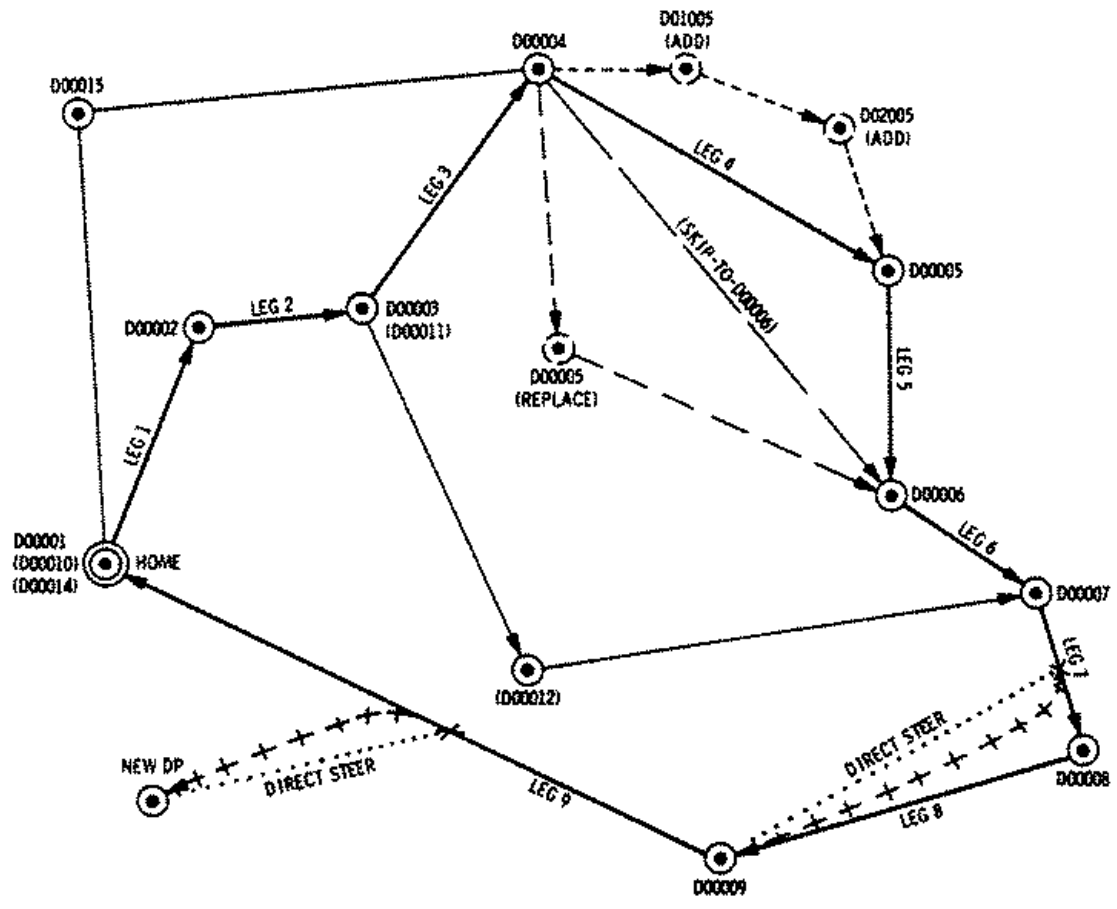

- TAPE-FILLED PRIMARY MISSION LEG
- TAPE-FILLED ALTERNATE MISSION LEG
- TAPE-FILLED DESTINATION POINT
- PANEL-FILLED DESTINATION POINT
- PANEL-FILLED SKIP-DP LEG
- PANEL-FILLED ADD-DP LEG
- PANEL-FILLED REPLACE-DP LEG
- PANEL OR TAPE-FILLED DIRECT STEER LEG

F203-254

Figure 4-54

ground speed. The second component trims bank angle trim as a function of the radial speed and position relative to the programmed radius so that the aircraft follows the planned turn line throughout the turn. If a transient causes the aircraft to deviate from the turn line, bank angle trim varies within $\pm 10^\circ$ to return to the turn line.

Range to destination as displayed on the HSI and the NCD includes distance around a turn rather than the length of the great circle from present position to destination. This distance around the turn is also used in computing time to turn for the NORMAL display.

located at the same radial distance from the turn line as the target.

The ASARS utilizes control point information to generate required parameters which are sent via a 64 word serial data bus. It contains such items as: aircraft velocities, target vectors, gravity anomaly values and radar operating modes. This information allows the ASARS computer to generate the desired imaging commands.

The mode commands to the TECH(s) are updated at each CP so that more than one sensor can be turned on or off at a single point. Dedicated CP's are required for ASARS operation. All CP's and FP's on a leg

are processed on that leg, even if a mission planning error or a panel-filled change puts a CP or FP past the start turn point at the end of a leg.

Control point information is displayed on the NCD panel. With the DATA SELECT switch in NORMAL the NCD can display either ASARS or non-ASARS fixpoint and control point ID's in SELECTED DATA window numbers 3 and 6. ASARS or non-ASARS information is alternately selectable via the ENTER/DISPLAY switch. ASARS control points in NORMAL are designated by AXXXX vice CXXXX for non-ASARS control points.

ASARS control point mode information can be displayed on the NCD panel. This information is displayed in SELECTED DATA window number 3 with the DATA SELECT switch in CONT PT. ASARS control point mode information is shown in Figure 4-55.

ASARS Control Point MODE

Digit 1: Always M
Digit 2: 0 = Normal 1 = Dual Spot (Not available) 2 = Measure Altitude
Digit 3: 0 = Neither Set 2 = Rewind 4 = Down Link (Not available) 6 = Both Set (Not available)
Digit 4: 0 = Frequency F1, Low Resolution 1 = Frequency F1, High Resolution 2 = Frequency F2, Low Resolution 3 = Frequency F2, High Resolution 4 = Frequency F3, Low Resolution 5 = Frequency F3, High Resolution 6 = Frequency F4, Low Resolution 7 = Frequency F4, High Resolution
Digit 5: 0 = Standby 1 = Acquisition/Measure Altitude 2 = Search 4 = Spot
SENSOR "L" On = Leave recorder on after this swath
SENSOR "L" Off = Turn recorder off after this swath

Figure 4-55

Fix Points (FPs)

FPs are accurately known and readily identifiable points along the mission path that are used in measuring ANS position error with the ASARS and Inflight Processor Display (IPD), viewsight or TACAN. FPs are used to determine ANS error at the time of the fix. The ANS can be corrected by depressing the UPDATE button, or the routine can be terminated without updating the ANS by depressing the MAN CLEAR pushbutton. FPs using ASARS can be used to improve ASARS pointing information without updating the ANS by pressing READ ERROR on the Radar Control panel but not pressing UPDATE.

The ASARS is automatically turned on prior to a planned fixpoint. Fixpoints define the end of an acquisition swath and may also be planned during a search swath. When a fixpoint is approaching, the IPD FIX legend appears and flashes. At the planned fixpoint the FIX legend will go steady, the moving imagery display freezes and crosshairs appear. At this time the IPD RUN/HOLD button indicates HOLD. The RSO uses the joystick to position the crosshairs over the fixpoint. Depressing the IPD READ ERROR button sends north-south and east-west errors

SECTION IV

TYPICAL ADD/REPLACE PLAN FOR FIX AND CONTROL POINTS

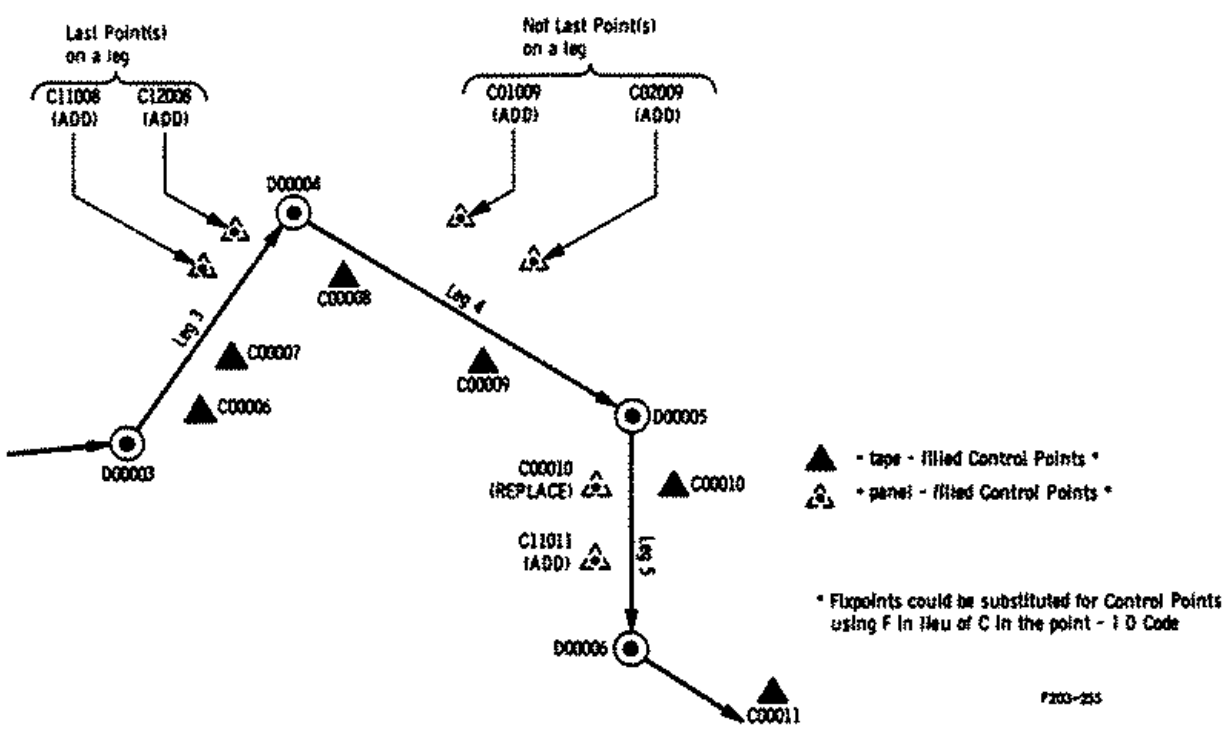

Figure 4-56

to the ANS and pointing information is corrected and used for all subsequent ASARS operations. The ASARS IPD will then resume preplanned operations and the RSO has the option of updating the ANS or clearing the errors. Clearing the ANS errors does not remove the ASARS pointing information correction.

ASARS fixes are accurate to about .050 nm CEP.

For viewsight FPs, the RSO normally uses wide angle view to search for the FP as it approaches. After identifying the FP, select narrow view, if possible, for maximum accuracy. As the FP passes down the

viewsight screen, move the cursor to intercept the FP as it passes under the nadir line. At that instant, press the viewsight READ switch. This provides the ANS with the location of the FP relative to the aircraft and allows measurement of ANS computed position error. Again, the errors appear in north-south, east-west values on the NCD after the READ switch is pressed. Viewsight fixes are accurate to about 0.5 nm CEP.

At TACAN FPs, ANS computed values of slant range and bearing to a TACAN station are displayed on the NCD for comparison with TACAN data observed on the BDHL. When a TACAN fix is desired, depress the TACAN switch, then enter the TACAN

values of magnetic bearing (xxx^o) and slant range (xxx nm) at the time the TACAN button was actuated. The ANS will then display the north-south and east-west errors. TACAN fixes are accurate to 2 to 3 nm at slant ranges from 20 to 200 nm. Accuracy is degraded at less than 20 nm and greater than 200 nm. The range data can generally be accepted, but TACAN bearing information may be somewhat inaccurate. When the INS is in the ATT mode, the TACAN mag bearing is correct, but the relative bearing may be in error.

If desired, the ANS computed position can be corrected by pressing the UPDATE switch; otherwise, press the MAN CLEAR switch to clear the measurement data. If FPs are used for updating, the ANS adjusts position, platform level, velocity, and heading based on the Kalman filter weighing matrices. The amounts applied to each of these parameters are optimized for the existing mode. Generally, corrections will not be necessary in the ASTRO INERTIAL mode although the measurement should be made to check the system.

Non-ASARS sensor operation may also be planned and commanded at FPs. The point of execution will be at the along track position determined by the FP abeam point plus the range-to-turn-on value in the FP data of the mission tape. The TECH(s) may be turned on or off at any tape-filled FP. The camera(s) will be pointed and have the modes programmed at previous CPs. ASARS does not utilize a non-ASARS CP or FP.

MISSION MODIFICATION

The tape-filled mission program can be modified through the NCD panel. Up to 40 sets of data (40-List) may be entered to replace or add to previously stored mission points. In addition, the operator can skip any number of tape-filled or panel-filled destination points, or change destination. There are also special panel-filled fixpoints called Anytime or Opportunity fixpoints that are exclusive of the 40-List.

Add or Replace CP-FP-DP Routine

The mission tape is stored in the tape-filled memory of the computer. Panel-filled data for mission modification is stored in the panel-filled memory of the computer. Only Add or Replace modifications use the 40 panel-filled memory cells. Data required for each type of point, both panel-filled 40 List and tape-filled points, is listed in Figure 4-11 (non-ASARS). If necessary, the RSO can clear any or all of the mission modification data entered into the panel-filled memory and enter new data in the same 40 memory spaces. Detailed knowledge of the tape-filled mission is required to modify that mission, especially when control points or fixpoints are added or replaced.

Point-ID Code (Non-ASARS)

Every tape-filled or 40-List mission point has an identification code. The code consists of a letter and five digits, referred to in the following text as digits 1, 2, 3, 4, and 5, counting from the left. This is the order in which the point-ID code is entered in the NCD panel. A letter C/C1, F/F1 or D designates the point as a control point, fixpoint, or destination point, respectively, and appears in the left-most display of the SELECTED DATA window 6 when a mission point is selected for display. When modifying a mission, this part of the ID code is entered by selecting FIXPOINT, CONT PT, or DEST POINT on the DATA switch.

Digits 3 thru 5 of the ID code denote the number assigned to each tape-filled CP, FP, and DP. Tape-filled points are numbered starting with 001 for the first CP, FP, and DP. In general, the points on the primary mission are numbered in sequence followed by the points on alternate legs. However, the sequence is not really important since the next point number of each type is listed with each tape-filled mission point; i.e., the data for DP 002 can define DP013 as the next DP, or vice versa. The same applies to CP's and FP's.

As shown on Figure 4-54, DP's which are the start points for alternate legs are doubly

SECTION IV

defined. This means that the same geographic point is contained in two different locations with different number and different next-point numbers (example: D00003 and D00011). The alternate leg is selected by skipping to D00011 when on leg 1. Note that the alternate path rejoins the primary mission at D00007; thus, both D00006 and D00012 list D00007 as the next DP. 40-List (ADD or REPLACE) points are defined relative to tape-filled points; digits 3 thru 5 define the tape-filled point to be replaced, or the tape-filled or panel-replaced point following the point(s) to be added.

Digit 2 is the "add" number for panel-filled ADD points. Digit 2 can range from 1 to 7 for the first through seventh points to be added ahead of the tape-filled or panel-replaced point of the same type defined by digits 3 thru 5, where add point X10YZ is the first add point encountered in the mission, ahead of point 000YZ with add point X20YZ the second, etc. Digit 2 is zero for tape-filled points or replaced points. Digit 2 is the left-most digit in the SELECTED DATA window 6 when a mission modification is performed or a mission point is displayed.

Digit 1 is a zero for all tape-filled points, replaced control or fix points, and 40-list destination points. When adding fix or control points, however, digit 1 is used by the computer to determine the track leg location of the new added point. If the add point is after the last tape-filled point of its type on its track leg, this digit is 1; if the add point is before the last tape-filled point of its type on its track leg, then the digit is a zero. Digit 1 appears as C1 or F1 in the letter position of the SELECTED DATA window 6 during a mission modification or mission point display operation (when ID code is entered). It also appears when a point is displayed.

Point ID Code (ASARS)

Like non-ASARS points every 40-List mission point has an identification code. The code consists of a letter and five digits, referred to in the following text as digits 1, 2, 3, 4 and 5, counting from the left. This is the order in which the point-ID code is entered in the

NCD panel. A letter C or F designates the ASARS point as a control point or fixpoint.

Digits 2 through 5 are the same as the corresponding digits of the non-ASARS Point-ID code. Digit 1 is always zero for all replaced ASARS Fixpoints and added or replaced ASARS control points. No ASARS control or fixpoints can be added after the last tape-filled point of its type on a track leg.

Sensor Selection Code (Non-ASARS)

The three-digit sensor selection code designates which sensor shall be turned on and/or remain on, at a panel-filled control point.

The first and second digits control L and R TECH camera operation. The third digit is always zero. When control points are added or replaced, take care not to disrupt prior turn-on commands to the TECH cameras. If, for example, the L TECH was automatically turned on 50 nm prior to an add R TECH control point, and the mission planner intended it to remain on for a total 100 nm swath, the add-control point sensor assignment code would be 110. This would tell the computer to leave the L TECH on at the new control point and that the R TECH will be turned on. This is necessary because each CP will turn sensors off without an "on" marker in the sensor code.

Left-Right Camera Pointing Code

The left-right marker designates which TECH camera to operate. When adding or replacing

SENSOR SELECTION CODE

SENSOR	CODE		
L TECH	1	0	0
R TECH	0	1	0
Verify code insertion on panel by illumination of appropriate sensor indicator.			

Figure 4-57

TECH camera control points, insert L000 or R000 for control points to the left or right of course respectively. Verify code insertion in the SELECTED DATA window 5 (R or L plus three numeric digits).

ASARS Control Point Code

A five digit code designates which feature of the ASARS will be activated at a panel-filled control point.

Digit 1 is used to select the dual spot mode. Digit 2 selects rewind and/or downlink options. Digit 3 specifies resolution and frequency characteristics. Digit 4 defines the mode and Digit 5 controls the recorder status. Digits 1 thru 4 are displayed in SELECTED DATA window 5 as they are entered. Selection of 1 for Digit number 5 will be indicated by illumination of the TECH L light. These codes are shown in Figure 4-58.

ASARS Fix Point Code

ASARS Fixpoints cannot be added. Fixpoints can be replaced by entering the new latitude, longitude, and terrain elevation.

40-List Add/Replace FP-CP-DP Limitations

Add/replace can be performed in any ANS mode except OFF or WARM UP. Add/replace alters the tape-filled mission. If the added point is located before the "next point" of each type on the current leg, or the replaced point is the current "next point" of each type, then the RSO must fill the new points into the 40-List and then perform a Track Leg Update. This will cause the ANS computer to recognize and use these new 40-List points. For example, if the first tape-filled leg is changed by replacing or adding DPs, a Track Leg Update will reinitialize the computer to the new first leg.

Any filled 40-List points located after the current "next tape-filled point" of each type will be utilized in the normal ANS sequence and no Track Leg Update is required (see Figure 4-56).

ASARS Control Point CODE

Digit 1:	L = Dual Spot (Not available) R = Normal
Digit 2:	0 = Neither Set 2 = Rewind 4 = Down link (Not available) 6 = Both Set (Not available)
NOTE:	Selection of 4 or 6 will result in no ASARS imagery being recorded.
Digit 3:	0 = F1, Low Resolution (Spot only) 1 = F1, High Resolution (Spot only) 2 = F2, Low Resolution (Acquisition and Search only) 3 = F2, High Resolution (Not available) 4 = F3, Low Resolution (Spot only) 5 = F3, High Resolution (Not available) 6 = F4, Low Resolution (Acquisition and Search only) 7 = F4, High Resolution (Not available)
NOTE:	Extreme care must be exercised in selecting resolution and frequency. Non-available combinations of mode (Digit 4) and Resolution/Mode may be selected resulting in no ASARS activity.
Digit 4:	0 = Standby 1 = Acquisition 2 = Search 4 = Spot
Digit 5:	0 = Turn recorder off after this swath 1 = Leave recorder on after this swath

Figure 4-58

NOTE

A FP/CP/DP in the 40-List must be deleted before a correction/modification can be made to that numbered point.

SECTION IV

ANS BANK ANGLE VS TURN RADIUS FOR VARIOUS MACH NUMBERS

FAT = -56°

Mach No. KTAS*	2.80 1606	2.85 1635	2.90 1664	2.95 1693	3.00 1721	3.05 1750	3.10 1779	3.15 1807	3.20 1836	3.25 1865
Bank Angle	Turn Radius (KR) - NM									
Deg.										
20	105	109	113	117	121	125	129	133	137	142
21	100	103	107	111	114	118	122	126	130	134
22	95	98	102	105	109	112	116	120	124	127
23	90	93	97	100	103	107	110	114	118	121
24	86	89	92	95	99	102	105	109	112	116
25	82	85	88	91	94	97	101	104	107	111
26	78	81	84	87	90	93	96	99	102	106
27	75	78	80	83	86	89	92	95	98	101
28	72	75	77	80	83	85	88	91	94	97
29	69	72	74	77	79	82	85	87	90	93
30	66	69	71	74	76	79	81	84	87	89
31	64	66	68	71	73	76	78	81	83	86
32	61	63	66	68	70	73	75	77	80	82
33	59	61	63	65	68	70	72	75	77	79
34	57	59	61	63	65	67	69	72	74	76
35	55	57	59	61	63	65	67	69	71	74
36	53	55	56	58	60	62	65	67	69	71
37	51	53	54	56	58	60	62	64	66	68
38	49	51	52	54	56	58	60	62	64	66
39	47	49	51	52	54	56	58	60	62	64
40	46	47	49	51	52	54	56	58	60	61
41	44	46	47	49	50	52	54	56	57	59
42	42	44	46	47	49	50	52	54	55	57
43	41	42	44	46	47	49	50	52	54	55
44	40	41	42	44	45	47	49	50	52	53
45	38	40	41	42	44	45	47	48	50	52

*KTAS based on Mach 1.0 = 573.6 knots at -56.5°C ambient air temperature.

KR = 14.815 (V/1000)² / Tan θ for ANS System turn; where V = KTAS, θ = bank angle.

Figure 4-59

automatically restarted. When the DIRECT STEER procedure is performed, ANS operate commands to the sensors are turned off. The ADD ANYTIME FP and OPPORTUNITY Viewsight Fix procedures are usable while in DIRECT STEER if the aircraft track remains within 2 degrees of the bearing to the DP during the Fix procedure.

Track Leg Update

The Track Leg Update procedure allows the RSO to change the current ANS track leg. Any track leg segment in the mission may be selected. The RSO fills the ID code number of the beginning DP of the leg he desires.

ANS TURN RADIUS VS. TRUE AIRSPEED & BANK ANGLE

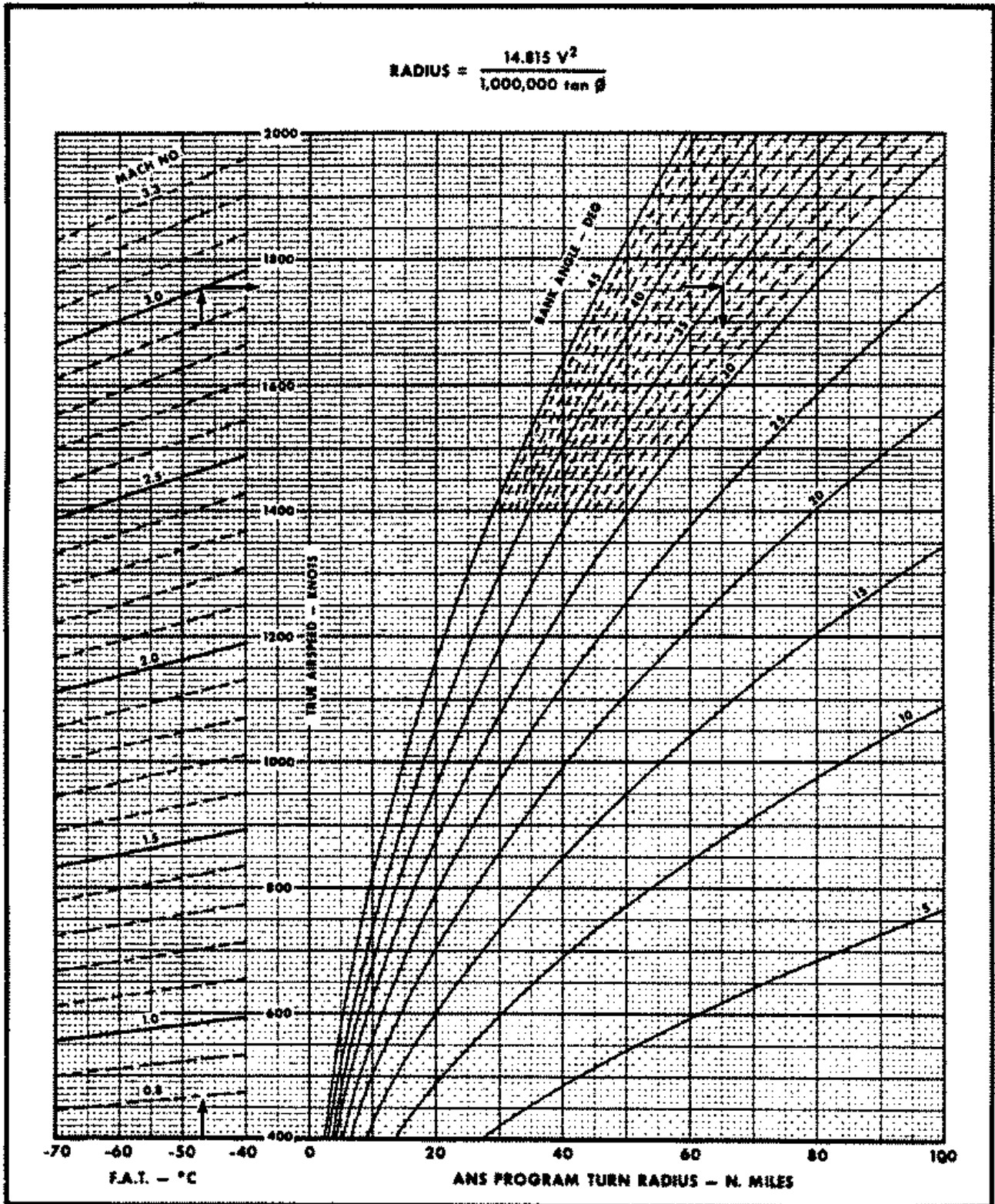

Figure 4-60

SECTION IV

NAVIGATION MODES VS ALIGNMENT METHODS

NAVIGATION MODE		ALIGNMENT METHOD WITH NDC -1070 COMPUTER
GROUND ACTIVATION	ASTRO INERTIAL INERTIAL ONLY	GYROCOMPASSING <ul style="list-style-type: none"> - Warm up 60 min - Coarse align 6 min - Fine align 29 min 55 sec 1st align - 12 min 15 sec slew 90° - 1 min 30 sec 2nd align - 16 min 10 sec } 95 min 55 sec RAPID <ul style="list-style-type: none"> - Warmup 60 min - Coarse align 6 min - Fine align 12 min } 78 min 15 sec GROUND HOT START <ul style="list-style-type: none"> - Coarse align 50 sec - Restart 30 sec } 90 sec
INFLIGHT ACTIVATION	AIRSTART	AIRSTART <ul style="list-style-type: none"> - Coarse Align Phase Until platform is rough leveled (< 40 arc min) - Restart Until platform is leveled (< 21 arc min) - Navigate Phase Continuous after platform leveling Dead Reckon Continuous from FILL PP (during coarse align) to ★ ON (steady) Search for Star A & B Continuous from platform leveling + 5 min to ★ ON illumination (steady) Air mass-damped, astro inertial navigation Continuous after ★ ON illumination (steady)

F202-254(4)

Figure 4-61

NOTE

The ANS then initializes to the leg from that DP to the next sequential tape-filled or 40-List DP. Great-circle navigation and sensor control are immediately conducted relative to this new leg. The ANS sequences through all FP's and CP's on the new leg up to the current computed along-track position, where sensor commands will be as programmed for that point on the track; normal auto-nav steering is performed, using a 30-degree approach to the new track, if necessary.

The RSO should perform a track leg update during a Hot or Cold Airstart and Ground Hot Start since the computer automatically re-initializes to the first track leg segment on the mission tape at system turn-on.

If the current groundspeed and/or present position satisfy turn start criteria to the next leg, then the ANS will accept the updated track leg and immediately "index" to that next track leg.

ANS OPERATION

The ANS must be warmed up and aligned before flight. The methods for ground and air alignment and their association with various navigation modes is outlined in Figure 4-61.

CHRONOMETER/OPERATION OPTIONS

Status of Chronometer Installed	RSO Mode Options	Hot Start Program Retained
A. Accurate, GO	Any	Yes
B. Inaccurate, GO	Do not fill DAY/TIME. INERTIAL ONLY selected after align.	Yes, no star tracking possible.
C. Inaccurate, GO	Fill DAY/TIME - ASTRO INERTIAL selected after align.	No, star tracking available. (Recommended procedure.)
D. NO/GO or Chronometer disconnected or not installed.	Any. But <u>any</u> power dropout of <u>any</u> duration will cause drop out of ANS. New alignment or Cold Airstart will be required. This situation very undesirable and ANS dropout is highly probable in flight due to electrical system interruption or transient below 103 volts.	No.

Figure 4-62

Prior to ground alignment, verify that the prescribed mission program is in the computer and that the portable chronometer is installed and operating. Power and cooling air are required continuously through warm-up, alignment, and navigation. Once alignment has started, a power interruption of more than 1 second will require realignment. Normally, warmup and alignment are performed on ground power and cooling air with transfer to aircraft power and cooling air after engine start, but can be performed on aircraft power and cooling air after engine start.

Tape 13 is compatible with increased altitude resolution from DAFICS. This feature requires hardware changes to DAFICS. To

verify correct system configuration the RSO must check proper altitude scaling by performing the Altitude Scaling Test routine. This routine compares the ANS altitude to the TDI. The altitude readings must agree, otherwise, notify maintenance.

When operating from an alternate base without ANS support personnel, the chronometer day/time accuracy must be checked. If a flight with an accurate chronometer installed terminates at an alternate base, the chronometer can be (a) maintained indefinitely in an accurate GO state by connecting ground power and cooling to the aircraft with the MODE switch OFF and the aft cockpit ANS essential DC circuit breaker in, or (b) left in the aircraft after

+

SECTION IV

normal shutdown procedures are completed. In the latter case, if the battery ON/OFF switch is left in the ON position, the chronometer battery will run down in approximately 24 hours and the chronometer will stop. After power is reapplied to the aircraft and the battery ON/OFF switch is in the ON position, the chronometer should display a GO status and begin to charge its internal battery. If the chronometer is in a GO status, but merely incorrectly set, fill DAY/TIME during C/A and operate in the ASTRO INERTIAL mode. (In a ground hot start, the C/A mode lasts only 60 seconds.) After filling DAY/TIME, the difference between RSO filled values and chronometer values is retained as a bias term to update the computer time following power dropouts of less than 1 second. Thus, astro inertial navigation should function normally. Power dropouts that exceed 1 second will not be compensated for.

After filling DAY/TIME a Hot Airstart cannot be performed and a new ground alignment or Cold Airstart is required. Chronometer options are listed in Figure 4-62.

NOTE

Takeoff without a chronometer or with a NO/GO is permitted but not recommended. ANS mode options are the same for any of these conditions, but are subject to conditions discussed under Power Dropout and Chronometer Failure in this section under Malfunction Indicator. Also refer to Flashing MAL Light On During Ground Operation and Flashing MAL Light On In Flight, this section.

Warmup

Turn the MODE switch from OFF to WARM UP. The MAL light will illuminate steady. Monitor the TEMP LIMIT light. If the light remains out, the MODE switch can be moved to an "operate" position. If the TEMP LIMIT light is on steady or flashing, immediately turn the MODE switch to OFF and check ANS cooling. The MODE window display is blank in the WARM UP mode.

Ground Alignment

When the MODE switch is moved from WARM UP to ALIGN or an "operate" mode, full operating power is applied to the entire system and alignment begins. The MODE window indicates the current phase of alignment. Initially, the MODE window reads C/A, and the computer starts the self and system test routines. A flashing MAL light comes on when full operating power comes on and is reset by pressing the MODE START, or RAPID, or HOT switch; it will relight if the computer test routines detect a malfunction or power dropout.

Upon successful completion of the test routines, the computer automatically starts alignment beginning with the coarse phase. Coarse alignment time (5 to 6 minutes) is the same for all ground-start cases except ground hot start.

Except for hot starts, fine alignment begins after completion of coarse alignment if present position coordinates have been entered. Do not enter present position until the TEMP TOLR light extinguishes.

NOTE

Except for hot starts, enter either magnetic variation or true heading prior to entering present position and field elevation.

The optimum method of alignment is gyrocompassing. The 30-minute fine-alignment phase includes gyrocompassing. Gyrocompassing determines the orientation of the platform relative to true north. Fine alignment accurately levels the platform to the local vertical.

An alternate method of ground alignment is the rapid alignment. In this mode, the system automatically goes directly to a 12-minute fine-align period from coarse align. During fine align, the gyros are rated and the platform is leveled. Since gyrocompassing is not performed, a runway heading alignment should be performed during takeoff following a rapid alignment unless the aircraft true

SECTION IV

NOTE

If star tracking is not possible due to aircraft location or sky conditions, leave the system in F/A. Otherwise place the system in ASTRO INERTIAL mode by setting the MODE switch to ASTRO INERTIAL and press MODE START. When A-I appears in the MODE window, inertial data is used for all ANS updates and displays and the star tracker will start searching for an "A" star.

The ANS uses the landing gear switch to distinguish between a ground hot start and a hot air start. Air mass damping is not performed following a ground hot start. Before a ground hot start, ground cooling air should be provided at 75°F if possible. Loading a new mission tape destroys the stored values of position and heading. If the stored heading is not accurate within 0.1° and the star ON light is off, a runway heading alignment should be performed following the ground hot start.

Takeoff

If the runway heading alignment routine is used, maintain takeoff roll parallel to runway centerline. This alignment is automatically terminated at lift-off by a switch on the left main landing gear strut. The RSO must press the UPDATE or MAN CLEAR pushbutton to end the procedure.

In-Flight

After takeoff, the tape-filled mission plan will be followed automatically except as modified by panel-filled inputs. Generally, the autopilot is engaged in the auto-nav mode to simplify flying the mission. Refer to Mission Tape Program and Mission Modification, this section, for a more complete discussion of navigation and sensor control.

Position fixes, using the TACAN, ASARS, and viewsight should be made at frequent intervals to verify and, if necessary, refine

computed position. The ANS errors measured by these systems are displayed on the NCD panel and may be cleared or entered into the ANS to correct present position. This is especially important in the alternate navigation modes.

TACAN FP accuracy is inherently worse than the viewsight, ASARS, or ANS fixes, so updates of the ANS by TACAN should only be entered when the ANS is positively known to have large errors.

The ANS software will weight the correction according to prestored accuracy estimates for the type of fixpoint and its current estimate of ANS accuracy. Hence the update command by the RSO will result in only a portion of the displayed error being accepted. The Remote Update routine will, however, always make a total position update by the amount commanded. On other types of fix updates, if either the latitude or longitude correction requested is greater than 5 nautical miles, the total amount will be accepted.

The NCD panel star ON light is an important indicator during astro-inertial and airstart operation. If the star ON light is out during astro-inertial operation, system error will increase at the inertial-only rate and extra effort should be made to check computed position. If the star ON light is on, astro-inertial performance will generally be good. Refer to Astro-Inertial Navigation, this section.

Airstart Alignment

Should there be an airborne power interruption or temporary malfunction, it may be possible to realign the ANS using the airstart procedure. A period of coarse alignment to level the platform is followed by a period when it may be possible to accurately level the platform for precision navigation by performing a series of fixes.

Present position can be entered any time after initiating the airstart procedure and is updated continuously thereafter by dead-reckoning computations. If present position has not been filled by the time the coarse

SECTION IV

ANS NORMAL PROCEDURES

The following ANS Tape 13 operating procedures are divided into the general categories of alignment, fill, update, change and display.

NOTE

In these procedures, only the indications that change as a result of procedural steps are listed. Assume that the display does not change if the indication of a particular display is not listed.

The L and R TECH and SLR NCD indicators will be off unless otherwise specified.

The MAL indicator must be off at all times except: it must be on steady while in the WARM UP mode and flash when the MODE switch has been turned from OFF or WARM UP to ALIGN, ASTRO INERTIAL, INERTIAL ONLY, DEAD RECKON, or AIRSTART; and must extinguish after the MODE START, HOT, or RAPID switch is pressed. Refer to the Emergency Procedures paragraph if the MAL light illuminates under any other circumstances.

"Operate" positions of the MODE switch means ALIGN, ASTRO INERTIAL, INERTIAL ONLY, DEAD RECKON, or AIRSTART.

If ERR is indicated in the MODE window, press the MAN CLEAR switch and restart the procedure.

ENT is displayed following the minimum coarse alignment period when present position/heading has not been filled.

When the MAN CLEAR switch is pressed (or the first keyboard switch is pressed after a panel routine is completed in a sequence of routines) the SELECTED DATA counters blank with the exception of a cue letter in one of the windows which will indicate the first data to be entered. The exact letter and window will depend on the DATA switch position. The PRESENT LATITUDE/LONGITUDE/WIND/NEXT DP/TIME TO TURN displays and the star ON, TEMP LIMIT, and TEMP TOLR indicator lights are not affected.

GROUND ALIGNMENT

Prior to ground alignment, an operating chronometer must be installed, the aircraft must be stationary, and the MODE switch must be OFF. Heading must be supplied within +28 degrees for gyrocompassing alignments, or +2 degrees for rapid alignment by the INS or TRUE HEADING UPDATE procedure.

1. MODE switch - WARM UP.
 - a. MAL light - On steady.
 - b. MODE window - Blank.

- c. TEMP LIMIT light - Off.

Turn MODE switch to OFF if TEMP LIMIT light illuminates.

- d. TEMP TOLR light - Off, on, or flashing.

2. MAG/GRID switch - MAG illuminated.
3. MODE switch - ALIGN, ASTRO INERTIAL, or INERTIAL ONLY.

Allow 5 minutes in WARM-UP before selecting an alignment mode.

- a. MAL light - Flashing.
 - b. MODE window - C/A.
 - c. PRESENT LATITUDE and LONGITUDE windows - Blank.
 - d. SELECTED DATA windows - Blank.
4. Check GMT and Julian Day using TIME Display.

If either GMT or Julian Day are in error replace the chronometer and restart the alignment. If a chronometer replacement is not available, fill DAY and TIME as accurately as possible. Time error greater than 2 seconds may result in star tracking but with erroneous ANS updating. If accurate star tracking cannot be accomplished, the ANS may be operated in the INERTIAL ONLY Mode.

NOTE

The ANS may be initialized without TIME only if INERTIAL ONLY is selected and MODE START is depressed.

5. For GYROCOMPASS alignment: MODE START - Press or
- For RAPID alignment: RAPID Switch - Press.
- a. MAL light - Off.
 - b. Star ON light - Flashing when artificial internal star is tracked.

If coarse alignment is completed before steps 6 through 8 are completed, MODE window will display ENT.

Perform step 6 or 7:

- 6. Use aircraft heading for TRUE HEADING UPDATE.

Enter known, accurate aircraft true heading, using the TRUE HEADING UPDATE procedure.

- 7. Use INS true heading for TRUE HEADING UPDATE.

Verify the INS is aligned and operating in NORM or NAV mode. Display INS true heading and insert these values into the ANS using the TRUE HEADING UPDATE routine.

NOTE

If the TRUE HEADING UPDATE routine is performed in coarse align or enter data, the updated true heading is used but will not be displayed until the ANS enters the fine align (F/A) mode.

When TEMP TOLR light off:

- 8. Fill present position and initial altitude (field elevation).

When coarse alignment is complete:

- a. For gyrocompassing alignment, MODE window displays F/A for at least 30 minutes.
- b. For rapid alignment, MODE window displays F/A for at least 12 minutes.

When the minimum alignment time has elapsed, present position is displayed in the PRESENT LATITUDE and LONGITUDE counters. After this occurs, and just before taxi, start navigation by performing steps 9 and 10.

Before taxiing:

- 9. MODE switch - ASTRO INERTIAL or INERTIAL ONLY.
- 10. MODE START - Press.
 - a. MODE window - A-1 or I/O.

SECTION IV

NOTE

If ASTRO INERTIAL or INERTIAL ONLY mode was selected in step 3, the system automatically starts astro inertial or inertial only navigation, and the MODE window indicates A-I or I/O when the minimum alignment time has elapsed.

If rapid alignment used and star light off:

11. Do a RUNWAY HEADING ALIGNMENT.

NOTE

This step is not required if at least one star has been tracked (B star), however, this might not be evident unless the DATA switch was placed to TIME. In any case, the star on light (C star) indicates at least two different stars have been tracked within the past 5 minutes.

GROUND ALIGNMENT CORRECT

The GROUND ALIGNMENT CORRECT routine torques the platform to earth rate at the local latitude and thus removes any velocity errors that may have built up during taxi. If it is expected that the aircraft will remain stationary for at least four minutes after the star ON light has illuminated, this procedure should be used. Since star tracking continues during ground align correct, star tracking data is used to correct heading and recompute the accelerometer null bias point. This procedure is normally performed after engine runup and before taxiing to the runway. If the ANS is in the ALIGN mode during engine runs, inertial errors may result from inadvertent aircraft movement. A ground alignment correct need not be performed if the ANS is not tracking stars unless a long mission delay occurs. Although any built-up velocity errors will be removed, the accelerometer null bias point is not recomputed. Returning to ALIGN under this circumstance prevents further platform deterioration by

retorquing it to local latitude earth rate, but any errors present will continue to affect the platform after this procedure until star tracking occurs. If ALIGN is selected from the INERTIAL ONLY mode and if INERTIAL ONLY is reselected after ground align correct, the first star tracked after ASTRO INERTIAL is selected will be an A-star.

1. MODE switch - ALIGN.
2. MODE START - Press.
 - a. MODE window - F/A.

Prior to start of taxi, initiate navigation by performing steps 3 and 4.

3. MODE switch - ASTRO INERTIAL or INERTIAL ONLY.
4. MODE START - Press.
 - a. MODE window - A-I or I/O.

NOTE

If the ground-alignment-correct time is less than 10 seconds, no alignment correction is made.

GROUND HOT START ALIGNMENT

A ground hot start must be preceded by a ground alignment or navigation operation so that an accurate present position, altitude, and heading are stored in the computer. Following the previous operation, the aircraft must be stationary, no tape-fill operations can be performed, and the MODE switch must be in OFF or WARMUP. Prior to the hot start cooling air should be available (75°F) and an operating chronometer should be installed. If the system has not been turned OFF, skip to step 2.

1. MODE switch - WARM UP.
 - a. MAL light - On steady.

- b. MODE window - Blank.
 - c. TEMP LIMIT light - Off.

Turn MODE switch to OFF if TEMP LIMIT light illuminates.
 - d. TEMP TOLR light - Off, on, or flashing.
2. MODE switch - ASTRO INERTIAL or INERTIAL ONLY.
- a. MAL light - Flashing.
 - b. MODE window - C/A.
 - c. PRESENT LATITUDE and LONGITUDE windows - Blank.
 - d. SELECTED DATA - Blank.

3. Check GMT & Julian Day using TIME display.

If either GMT or Julian Day are in error, replace the chronometer and realign the ANS. If a chronometer replacement is not available, fill DAY and TIME as accurately as possible. TIME error greater than 2 seconds may result in star tracking but with erroneous ANS updating. If accurate star tracking cannot be accomplished, the ANS may be operated in the INERTIAL ONLY mode.

- 4. HOT switch - Press.
- 5. Check True Heading and present position.

NOTE

If true heading and/or present position are changed (or not accurate) since previous shutdown, turn system OFF and perform a Rapid or Gyrocompass alignment.

- 6. Use TRACK LEG UPDATE for initial DP.
- 7. MODE window - RES.

- 8. MODE window - F/A.

Before taxiing:

- 9. MODE switch - ASTRO INERTIAL or INERTIAL ONLY.
- 10. MODE START - Press.
 - a. MODE window - A-I or I/O.

When aligned on runway and no "A" star:

- 11. Do RUNWAY HEADING ALIGNMENT.

Not required if at least one star has been tracked (flashing star ON light).

COLD AIRSTART ALIGNMENT

NOTE

If a power dropout has occurred, skip to step 3 if HOT or MODE START has not been pressed after power returns.

- 1. MODE switch - OFF.
 - a. All NCD panel lights & windows - Extinguished/Blank.
- 2. MODE switch - WARM UP.
 - a. MAL light - On steady.
 - b. MODE window - Blank.
 - c. TEMP LIMIT light - Off.

Turn MODE switch to OFF if TEMP LIMIT light illuminates.

- d. TEMP TOLR light - Off, on, or flashing.
- 3. Adjust to straight and level flight.

Make necessary heading, altitude, and airspeed changes before continuing since the aircraft should be maintained as

SECTION IV

steady as possible throughout the air-start until the star ON illuminates, especially during C/A.

4. MODE switch - AIRSTART.
 - a. MAL light - Flashing.
 - b. MODE window - C/A.

NOTE

I/O appears in the MODE window if chronometer time and day are not available.

- c. PRESENT LATITUDE & LONGITUDE windows - Blank.
 - d. SELECTED DATA windows - Blank.
5. MODE START - Press.
 - a. MAL light - Off.
6. Check GMT & Julian Day using TIME Display.

If either time or day are in error, fill as accurately as possible. Time error greater than 2 seconds may result in star tracking but with erroneous ANS updating.

NOTE

If an error is made filling TIME and DAY, the routine may be repeated as long as the system is in C/A or ENT and the correct number of digits and ENTER/DISPLAY have been pressed first.

If accurate star tracking cannot be accomplished, select INERTIAL ONLY and press MODE START after the MODE window changes to A-L. If INERTIAL ONLY Mode is selected before C-star tracking, ANS present latitude and longitude will be DEAD RECKON coordinates. Monitor ANS attitude.

7. Check True Heading and Update if required.

An accurate True Heading should be displayed during C/A since the ANS uses the current INS magnetic heading and the last computed value of Δ PSIM, (this value normally equates to magnetic variation since it is the difference between the ANS inertial true heading and INS magnetic heading). If a heading error exists in the INS, Δ PSIM will be MAG VAR plus or minus INS heading error. Δ PSIM is updated every 4 minutes along with the DR position update and is also computed whenever ANS power is lost. If the aircraft does not fly through more than $1-1/2^\circ$ of variation from the time this value is computed until RES appears in the MODE window, the ANS heading should be accurate enough to track stars. If MAG VAR is filled, the computed value of MAG VAR (Δ PSIM) is superseded. A true heading error could result from adding a geographically accurate MAG VAR to an inaccurate INS magnetic heading. In any case filling MAG VAR will only change true heading and true heading display when in C/A. Fill MAG VAR has no effect on heading or heading display in RES or A-L. If a true heading update routine is performed during C/A or ENT, the updated true heading will not be displayed until RES. True heading may be updated and displayed in RES or A-L. The TRUE HEADING UPDATE routine will override the fill MAG VAR routine regardless of their sequence. The inertial frame uses the true heading at the end of C/A to begin inertial navigation.

The RSO has three options for true heading in the ANS: do nothing and let the last computed value of the MAG VAR (Δ PSIM) determine the true heading; fill a true heading (using tanker heading for example); or fill MAG VAR. If INS heading appears normal, the first option is recommended.

8. Fill Lat/Long of point ahead.

Insert latitude and longitude of a point to be overflown at a convenient distance ahead, using FILL PP procedure, but do not press ENTER switch until step 9.

9. ENTER switch - Press when over selected point.

PRESENT LATITUDE and LONGITUDE windows continually update, using dead-reckon data. Dead reckon data is used for great-circle navigation, sensor control, and all ANS outputs except pitch and roll which are not functional until the completion of coarse alignment.

10. Use TRACK LEG UPDATE or DIRECT STEER as required.

11. MODE window - Check for RES.

When MODE window changes to RES, C/A is complete.

- a. ANS pitch, roll, and heading outputs are now functional and reflect inertial data.
- b. Internal inertial navigation begins and inertial heading used for DR and heading.
- c. Auto-Nav usable, aircraft straight and level.

The autopilot can now be engaged, using ANS attitude reference. Any turns or attitude changes made during the RES mode will affect platform leveling and may prevent subsequent star tracking when the ANS goes into the A-I mode. Avoid engaging Auto-Nav in RES unless necessary.

12. Use DISPLAY PRESENT POSITION procedure to compare inertial and dead-

reckoning computations. Update dead-reckon present position using TACAN, viewsight, radar or PRESENT POSITION FILL procedures.

13. MODE window - Check for A-I.

MODE window display changes to A-I to indicate completion of true airspeed coarse leveling, beginning of star search, and the beginning of air-mass damping.

14. FILL WIND, as necessary.

NOTE

Wind can be filled for use in dead-reckoning navigation either in an airstart or when dead-reckon has been selected. Filling wind does not affect inertial navigation.

Perform FILL WIND procedure, as necessary, until star ON illuminates to keep the D.R. position accurate.

Use the REMOTE UPDATE routine to correct inertial position and re-initialize star search if inertial errors exceed 10 NM.

15. Check star ON light.

Acquisition of star A is indicated by flashing of the star ON light. When star B is acquired, the star ON light goes out. After the star ON light illuminates steady, inertial data is used to update all ANS outputs and internal dead-reckon data. If the autopilot is engaged in AUTO-NAV an aircraft maneuver will occur.

16. Update Present Position as required.

All inertial position error may not be yet removed even though the star light is illuminated.

SECTION IV

HOT AIRSTART ALIGNMENT

NOTE

If system has not been turned OFF, skip to Step 2.

1. MODE Switch - WARM UP.
 - a. MAL light - On steady.
 - b. MODE window - Blank.
 - c. TEMP LIMIT light - Off.

Turn MODE switch to OFF if TEMP LIMIT light illuminates.
 - d. TEMP TOLR light - Off, on, or flashing.
2. MODE switch - ALIGN, ASTRO INERTIAL, INERTIAL ONLY, or AIRSTART.
 - a. MAL light - Flashing.

NOTE

The flashing MAL light after a power dropout indicates power restoration and inertial position extrapolation occurs. Inertial position at the time power was removed is moved at TAS rate along the inertial heading at the time power was lost for a time interval equal to the period from power off to power on. This position extrapolation has nothing to do with when the RSO presses HOT. For 45-50 seconds after the MAL light begins flashing, nothing is done with the platform. At the end of this period, platform leveling begins if HOT has been pressed.

- b. MODE window - C/A. (If I/O, perform a COLD AIRSTART)

NOTE

If the MODE window display is I/O, turn the system off and perform a COLD AIRSTART. I/O appears in the MODE window if chronometer time and day are not available.

- c. PRESENT LATITUDE & LONGITUDE windows - Blank.
- d. Selected data windows - Blank.
3. Check GMT & Julian Day using TIME Display. If in error, perform a COLD AIRSTART.

If either time or day are in error, turn the MODE switch OFF and perform a COLD AIRSTART. Accurate position extrapolation cannot occur with erroneous time.
4. Adjust to straight and level flight.

Make necessary heading, altitude, and airspeed changes before continuing since the aircraft should be maintained as steady as possible throughout the airstart until the star ON light illuminates, especially during C/A.

5. HOT switch - Press.
 - a. MAL light - Off.
 - b. Present position windows - DR data.
 - c. Platform leveling is enabled.
6. FILL WIND, as necessary.

NOTE

Wind can be filled for use in dead-reckoning navigation either in an airstart or when DEAD-RECKON has been selected. Filling wind does not affect inertial navigation.

Perform FILL WIND procedures as necessary until the star light illuminates to keep DR position as accurate as possible.

7. Check True Heading and Update if required.

True Heading during C/A is INS heading and the last computed value of magnetic variation (Δ PSIM). This heading is used to drive the extrapolated Inertial position as well as the Dead Reckon position. Operation, display, and update of True Heading during C/A, RES, and A-I is identical to that during the COLD AIRSTART.

8. Check current track leg - Perform TRACK LEG UPDATE or DIRECT STEER, if required.

NOTE

An Auto Track Leg Update is initiated to the track leg on which the hot airstart is performed. If a direct steer had been performed on the leg on which the airstart is attempted then initialization will be to DP 1. SKIP TO operations initiated before a hot airstart are not retained.

9. MODE window - Check for RES.

When MODE window display changes to RES, C/A is complete.

- a. ANS pitch, roll, and heading outputs are now functional and reflect Inertial data.
- b. Internal inertial navigation begins and inertial heading used for DR and heading.
- c. Auto-nav usable, aircraft straight & level.

The autopilot can now be engaged, using ANS attitude reference. Any

turns or attitude changes made during the RES mode will affect platform leveling and may prevent subsequent star tracking when the ANS goes into the A-I mode. Avoid engaging Auto-Nav in RES unless necessary.

NOTE

If the platform precesses beyond $2-1/2^\circ$ of tilt from the time power is removed until the time platform leveling is enabled, the ANS will probably not come out of C/A into RES mode in a reasonable period of time and a COLD AIRSTART will have to be performed to level the platform.

10. MODE window - A-I.

MODE window display changes to A-I to indicate completion of true airspeed coarse leveling, and the beginning of star search, and air-mass damping.

NOTE

Even if the MODE switch is in ALIGN, INERTIAL ONLY, or AIRSTART when HOT is pressed, the system will automatically go into ASTRO INERTIAL mode during a HOT AIRSTART.

11. Check star ON light.

Acquisition of star A is indicated by flashing of the star ON light. When star B is acquired, the star ON light goes out. After the star ON light illuminates steady, inertial data is used to update all ANS outputs and internal dead-reckon data. If the autopilot is engaged in AUTO-NAV, an aircraft maneuver will occur.

SELECT DEAD RECKON MODE

The DEAD RECKON mode can be selected any time in flight.

SECTION IV

1. MODE switch - DEAD RECKON.
2. MAG/GRID switch - MAG.
3. MODE START - Press.
 - a. MAL light - Off.

If on, refer to Emergency Procedures paragraph.

- b. MODE window - D/R.
4. True Heading - Check, fill Mag Var as required.

Check true heading. Fill MAG VAR as required to keep the true heading as accurate as possible. When the DEAD RECKON mode is initially entered, magnetic variation should not have to be filled since the true heading will be the last computed value of Δ PSIM (the difference between the ANS inertial true heading and INS magnetic heading).

5. Fix and Update Present Position as required.

Fill present position if DEAD RECKON is selected from OFF or WARM UP.
6. FILL WIND, as necessary.

NOTE

Wind can be filled for use in dead-reckoning navigation either in an air start or when dead-reckon has been selected. Filling wind does not affect inertial navigation.

PRESENT LATITUDE and LONGITUDE windows are clear until filled if DEAD RECKON is selected from OFF or WARM UP, or during a "cold" airstart. Otherwise, the PRESENT LATITUDE and LONGITUDE counters are continuously updated from their initial reading as soon as MODE START is pressed.

The ANS assumes 0 degrees roll and 6 degrees pitch when VIEWSIGHT PP UPDATE

procedure is performed in the DEAD RECKON mode; therefore, the aircraft should be straight-and-level for viewsight fixpoints. If another operate mode is selected from DEAD RECKON, even prior to star ON light illumination in a "cold" or "hot" airstart, dead-reckon position and magnetic variation are updated to inertial data at 4-minute intervals in the new mode.

RUNWAY HEADING ALIGNMENT

The aircraft should be aligned with runway centerline. MODE switch must be in ASTRO INERTIAL or INERTIAL ONLY position. MODE window display must match MODE switch position. A heading correction will be inhibited if star B was successfully acquired as the first star after ground alignment.

1. DATA switch - HEADING.
2. Runway True Heading - Enter (XXX° XX.X').

Enter known runway true heading in degrees (three digits), minutes (two digits), and tenths of minutes (one digit). Entered data appears in SELECTED DATA 4 window.

3. MODE START - Press.

Press just before takeoff roll.

At liftoff:

4. Check ANS computed True Heading in SD-1 window.

At aircraft lift-off, average ANS heading appears in degrees (three digits), minutes (two digits), and tenths of minutes (one digit).

Perform step 5 or 6:

5. UPDATE switch - Press.

Press to incorporate difference between average ANS and runway headings.

6. MAN CLEAR switch - Press.

NOTE

If computed runway heading does not appear in SD-1 window at lift-off, the takeoff switch has probably failed; in this case, press MAN CLEAR to terminate the procedure.

FILL PRESENT POSITION AND INITIAL ALTITUDE

In any "operate" mode, when MODE window displays C/A, ENT, RES, A-I or D/R for other than initial fill for ground align.

NOTE

Either magnetic variation or true heading must be entered for ground alignment prior to FILL PRESENT POSITION and INITIAL ALTITUDE or an ERR indication will appear after ENTER is pressed.

If present position is filled in flight, position coordinates should be those that will exist when ENTER is pressed. Any present position filled after the COARSE ALIGN (C/A) phase will be entered into the dead reckon reference frame.

If not a ground Alignment, do steps 1, 2, 3, & 5:

1. DATA switch - PRES POSITION.
2. Fill Latitude (N/S XX°XX.XX').

Enter N or S position latitude in degrees (two digits), minutes (two digits), and hundredths of minutes (two digits). Entered data appears in SD-1 window.

3. Fill Longitude (E/W XXX°XX.XX').

Enter E or W position longitude in degrees (three digits), minutes (two digits), and hundredths of minutes (two digits). Entered data appears in SD-4 window.

4. Local Field Elevation - Enter (XXX) in hundred feet.

Entered data appears in SD-3 window.

5. ENTER switch - Press.

FILL WIND

MODE switch in any "operate" mode. MODE window displays any mode.

1. DATA switch - TEST.
2. Wind direction - Enter (XXX°).

Entered data appears in SD-5 window.

3. Wind speed - Enter (XXX).

Enter wind speed in knots (three digits). Entered data appears in SD-6 window.

4. ENTER switch - Press.

FILL DAY AND TIME

Day and time may be filled only when the ANS is in COARSE ALIGN. Attempting to enter day/time in any other mode will result in ERR in the MODE window.

NOTE

The MODE window normally reads C/A or ENT when the ANS is in the C/A mode. Whenever the ANS has power restored after a power loss and chronometer day and time are not available, the ANS will be in the C/A mode although the MODE window will read I/O and the MAL light will be flashing.

1. DATA switch - TIME.
2. Julian Day - Enter (8XXX).

Enter Julian day of year (four digits). Entered data appears in SD-6 window.

SECTION IV

NOTE

Fill Julian day to correspond with GMT.

3. GMT - Enter (XX hr, XX min, XX sec).

Entered data appears in SD-1 window.

4. ENTER switch - Press & release at time hack.

Filled day and time are entered when the ENTER switch is released.

NOTE

If an error is made in filling day and time the routine may be repeated as long as the correct number of digits and ENTER have been pressed first. If the MAL light is flashing in C/A and an error is made in filling day and time which results in ERR in the MODE window, press MAN CLEAR and reenter data.

FILL DAY

If a chronometer has the correct time but the wrong Julian Day, then a FILL DAY routine will be required during COARSE ALIGN to permit accurate star tracking.

1. DATA switch - TIME.
2. Julian Day - Enter (#XXX).
3. ENTER switch - Press.

FILL MAGNETIC VARIATION

In any "operate" mode:

1. DATA switch - HEADING.
2. Variation - Enter (E/W XXX^oXX.X').

Entered data appears in SD-4 window.

3. ENTER switch - Press.

NOTE

This routine is only functional if the system is in the MAG mode.

HEADING UPDATE

In any "operate" MODE:

1. DATA switch - HEADING.
2. True Heading - Enter (XXX^oXX.X').

Entered data appears in SD-4 window.

3. UPDATE switch - Press.

If this procedure is performed during the coarse align mode, entered value of heading will be used to initialize system true heading. If performed during fine align or any navigate mode, entered value will replace existing true heading.

NOTE

Unless the system is in C/A, the ANS will accept a maximum heading update change of 28^o. For an update change greater than 28^o the routine will have to be repeated until the desired heading to be updated is within 28^o of the system's last known heading.

**PRESENT POSITION UPDATE,
USING REMOTE SOURCE DATA
(REMOTE UPDATE)**

The maximum allowable correction is 90 nautical miles. The correction always goes to the inertial frame regardless of system mode. A dead-reckoned position cannot be updated by this procedure. The correction moves the inertial frame by the desired amount, i.e., if the aircraft is 0.5 nm south of the known location, a remote update of N0000.50 should be performed.

In any "operate" mode:

1. DATA switch - PRES POSITION.
2. N or S Correction - Enter (N/S 00XX.XX nm).

Entered data appears in SD-1 window.

3. E or W Correction - Enter (E/W 000XX.XX nm).

Entered data appears in SD-4 window.

4. UPDATE switch - Press.

**PRESENT POSITION UPDATE,
USING ASARS WITH IPD**

MODE: ASTRO INERTIAL, INERTIAL ONLY, or AIRSTART; MODE window displays any mode except F/A or ENT.

1. Mode M/A switch - A.
2. Fix warning - Flashing.

When imagery stops scrolling:

3. RUN/HOLD switch - HOLD illuminated.
4. Radar crosshair - Place over fixpoint.
5. READ ERR switch - Press.

Changes ASARS Pointing Information.

- a. Cumulative north or south ANS-computed error (sum of all radar fixes since NAV update) in nautical miles (two digits), and hundredths of miles (two digits) appears in SD-1 window.
- b. Cumulative east or west ANS-computed error (sum of all radar fixes since NAV update) in nautical miles (two digits), and hundredths of miles (two digits) appears in SD-4 window.
- c. Fixpoint north or south ANS-computed error in nautical miles (two digits), and tenths of miles (one digit) appears in SD-2 window.

- d. Fixpoint east or west ANS-computed error in nautical miles (two digits), and tenths of miles (one digit) appears in SD-5 window.

Do step 6 or 7:

6. UPDATE switch - Press.

Automatically updates ANS present position.

7. MAN CLEAR switch - Press.

Bypasses updating of ANS present position.

**MEASURE ALTITUDE UPDATE,
USING ASARS WITH IPD**

MODE: ASTRO INERTIAL, INERTIAL ONLY, or AIRSTART; MODE window displays any mode except F/A or ENT.

1. MODE M/A switch - A.
2. FIX warning - Flashing.

When imagery stops scrolling:

3. RUN/HOLD switch - HOLD illuminated.
4. Radar crosshair - Align with left edge of return.
5. READ ERR switch - Press.

Changes ANS NAV altitude.

**PRESENT POSITION UPDATE, USING
VIEWSIGHT**

MODE: ASTRO INERTIAL, INERTIAL ONLY, DEAD RECKON, or AIRSTART; MODE window displays any mode except F/A or ENT.

1. FOV switch - Select desired field of view.
2. Viewsight Cursor - Align with fixpoint.

When fixpoint under nadir:

3. READ switch - Press.

SECTION IV

- a. North or south ANS-computed error in nautical miles (two digits), and hundredths of miles (two digits) appears in SD-1 window.
- b. East or west ANS-computed error in nautical miles (two digits), and hundredths of miles (two digits) appears in SD-4 window.

Do step 4 or 5.

4. UPDATE switch - Press.

Automatically corrects ANS present position.

5. MAN CLEAR switch - Press.

Bypasses updating of ANS present position.

The ANS automatically sequences to the following FP 17.25 nm past a viewsight FP.

PRESENT POSITION UPDATE, USING TACAN (TAPE FILLED POINT)

In any "operate" mode:

1. BDHI HDG select switch - INS.
2. BDHI No. 1 needle select switch - TACAN.
3. Use Display Next FP, or Display Selected FP procedure.
4. TACAN switch - Press.

Press when TACAN system values have been noted on BDHI. All SELECTED DATA displays will clear.

5. TACAN mag bearing value - Enter (XXX^o).

Enter TACAN value of magnetic bearing from aircraft to station in degrees (three digits). Entered data appears in SD-5 window.

6. TACAN slant range value - Enter (XXX nm).

Entered data appears in SD-6 window.

7. ENTER switch - Press.

- a. SD-1 window displays north or south ANS computed error in nm and hundredths of miles.

- b. SD-4 window displays east or west computed error in nm and hundredths of miles.

Do step 8 or 9:

8. UPDATE switch - Press.

Automatically updates ANS present position.

9. MAN CLEAR switch - Press.

Bypasses updating of ANS present position.

The ANS automatically sequences to the next FP when 17.25 nm past a TACAN FP.

PRESENT POSITION UPDATE, USING TACAN (ANYTIME TACAN FP)

In any "operate" mode:

1. BDHI HDG select switch - INS.
2. BDHI No. 1 needle select switch - TACAN.
3. DATA switch - FIX POINT.
4. Fixpoint Latitude - Enter (N/S XX^oXX.XX').

Enter N or S and latitude of fixpoint in degrees (two digits), minutes (two digits), and hundredths of minutes (two digits). Entered data appears in SD-1 window. If any of the sensor operation indicator lights are illuminated, they extinguish when N or S is pressed. The

automatic sensors continue to operate normally during the add anytime TACAN fixpoint routine.

- 5. Fixpoint Longitude - Enter (E/W XXX°XX.XX').

Enter E or W and longitude of fixpoint in degrees (three digits), minutes (two digits) and hundredths of minutes (two digits). Entered data appears in SD-4 window.

- 6. Fixpoint Elevation - Enter (XXX).

Enter elevation of fixpoint in hundreds of feet (three digits). Entered data appears in SD-3 window.

- 7. Variation - Enter (E/W XX.XX°).

Enter E or W magnetic variation of TACAN station in degrees and tenths of degrees of arc as follows: E or WXX.XX°. Entered data will appear as follows:

- a. E/W in SD-5 window.
- b. Tens, units, and tenths of degrees in SD-5 window following E/W. Hundredths of degrees is not displayed.

NOTE

The maximum value of magnetic variation which can be entered is 99.99°. ANYTIME TACAN fixpoints cannot be used if actual magnetic variation exceeds this value.

- 8. ENTER switch - Press.
 - a. SD-2 window displays computed TACAN slant range.

- b. SD-5 window displays computed TACAN bearing.

- 9. TACAN switch - Press.

Press when TACAN system values have been noted on BDHI. All SELECTED DATA displays will clear.

- 10. TACAN mag bearing value - Enter (XXX°).

Enter TACAN value of magnetic bearing from aircraft to station in degrees (three digits). Entered data appears in SD-5 window.

- 11. TACAN slant range value - Enter (XXX nm).

Entered data appears in SD-6 window.

- 12. ENTER switch - Press.

- a. SD-1 window displays north or south ANS computed error in nm and hundredths of miles.
- b. SD-4 window displays east or west ANS computed error in nm and hundredths of miles.

Do step 13 or 14:

- 13. UPDATE switch - Press.

Automatically updates ANS present position.

- 14. MAN CLEAR switch - Press.

Bypasses updating of ANS present position.

The ANS automatically sequences to the next FP when 17.25 nm past a TACAN FP.



SECTION IV

RECALL ANYTIME TACAN FIXPOINT

MODE in any "operate" mode; an ANYTIME TACAN FIXPOINT must have been previously entered using the TACAN (ANYTIME TACAN FP) procedure. If more than one ANYTIME TACAN FIXPOINT has been entered, the last entered fixpoint will be recalled. Verify that the proper TACAN station is selected and that the TACAN T/R mode is set.

- 1. BDHI HDG select switch - INS.
- 2. BDHI No. 1 needle select switch - TACAN.
- 3. DATA switch - FIX POINT.
- 4. RECALL switch - Press.

NOTE

Step 4 will recall the last entered ANYTIME TACAN FIXPOINT. If there is none, the MODE window indicates ERR.

- 5. TACAN switch - Press.

Press when TACAN system values have been noted on BDHI. All SELECTED DATA displays clear.

- 6. TACAN mag bearing value - Enter (XXX^o).

Enter TACAN value of magnetic bearing from aircraft to station in degrees (three digits). Entered data appears in SD-5 window.

- 7. TACAN slant range value - Enter (XXX nm).

Entered data appears in SD-6 window.

- 8. ENTER switch - Press.
 - a. SD-1 window displays north or south ANS computed error in nm and hundredths of miles.
 - b. SD-4 window displays east or west computed error in nm and hundredths of miles.

Do step 9 or 10:

- 9. UPDATE switch - Press.

Automatically corrects ANS present position.

- 10. MAN CLEAR switch - Press.

Bypasses updating of ANS present position.

The ANS automatically sequences to the next FP when 17.25 nm past a TACAN FP.



PRESENT POSITION UPDATE, USING OPPORTUNITY VIEWSIGHT FIXPOINT

MODE in any "operate" mode; MODE window indicates any mode except C/A, F/A, or ENT.

1. Magnification - Set desired field of view.
2. Viewsight cursor - Align with fixpoint.

When Fixpoint under nadir:

3. READ switch - Press.
 - a. SD-1 window - Meaningless number.
 - b. SD-4 window - Meaningless number.
4. Fixpoint Latitude - Enter (N/S XX°XX.XX').

Entered data appears in SD-1 window.

5. Fixpoint Longitude - Enter (E/W XXX°XX.XX').

Entered data appears in SD-4 window.

6. Fixpoint Elevation - Enter (XXX) in hundreds of feet.

Entered data appears in SD-3 window.

7. ENTER switch - Press.
 - a. North or south ANS computed error in nautical miles (two digits) and hundredths of miles (two digits) appears in SD-1 window.

- b. East or West ANS computed error in nautical miles (two digits) and hundredths of miles (two digits) appears in SD-4 window.

NOTE

If an error is made when entering data (other than entering too many digits) press ENTER pushbutton and re-enter all data. If MODE window displays ERR press MAN CLEAR to terminate procedure and bypass present position update.

Do step 8 or 9:

8. UPDATE switch - Press.
 Automatically updates ANS present position.
9. MAN CLEAR switch - Press.
 Bypasses updating of ANS present position.

TRACK LEG UPDATE

MODE switch in ASTRO INERTIAL, INERTIAL ONLY, DEAD RECKON, or AIR START position; MODE window displays any mode.

1. DATA switch - DEST POINT or NORMAL.
2. Enter point - ID code (five digits) of start DP on desired track leg. Last four entered digits appear in SD-6 window, (first digit, always zero, replaces letter P with D).
3. UPDATE switch - Press.

SECTION IV

DIRECT STEER

In any "operate" mode:

1. DATA switch - DEST POINT or NORMAL.

For direct steer to tape-filled or panel-filled DP:

2. Enter five digit ID code of DP in memory (tape-filled or panel-filled). Last four entered digits appear in SD-6 window.
3. DIR STEER switch - Press.

For direct steer to new DP:

4. Enter latitude of new DP in degrees (two digits), minutes (two digits), and hundredths (two digits). Entered data appears in SD-1 window.
5. Enter longitude of new DP in degrees (three digits) minutes (two digits), and hundredths (two digits). Entered data appears in SD-4 window.
6. DIR STEER switch - Press.

The ANS automatically proceeds to the next great-circle leg if Direct Steer DP is in memory. The ANS commands a constant 35 degree, right wing down turn upon passing a new Direct Steer DP, or a DP with no next leg.

SKIP TO DP

In any "operate" mode:

1. DATA switch - DEST POINT or NORMAL.

2. Enter five digit ID code of DP to be skipped to. Last four digits appear in SD-6 window.
3. SKIP TO switch - Press.

**DELETE FP, CP, AND DP
(40-LIST)/CLEAR 40 LIST**

This procedure permits deleting points from the 40-List (panel-filled Add/Replace points). After a point is deleted the vacated space may be reused. In any "operate" mode:

Do steps 1, 2, & 4 for single point deletion.
Do steps 1, 3, & 4 to clear entire 40-list.

1. DATA switch - DEST POINT, FIX POINT, CONT PT.
2. Enter ID code (five digits) of FP, CP or DP to be deleted. All digits appear in SD-6 window.
3. ID CODE 99999 - Enter.
4. DELETE switch - Press.

ADD ANYTIME FIXPOINT

Normally, this procedure is followed closely by a Present Position Update procedure, using the ASARS or Viewsight. It can only be used on the existing leg, as no ID code is established for the Anytime Fixpoint.

In any "operate" mode:

1. DATA switch - FIX POINT.
2. Fixpoint Latitude - Enter (N/S XX°XX.XX').

Entered data appears in the SD-1 window.

NOTE

If any of the sensor operation indicator lights are illuminated, they extinguish when N or S is pressed. The automatic sensors continue to operate normally during the add Anytime Fixpoint routine.

3. Fixpoint Longitude - Enter (E/W XXX°XX.XX).

Entered data appears in SD-4 window.

4. Fixpoint Elevation - Enter (XXX).

Enter the terrain elevation of the fixpoint in hundreds of feet (three digits). For example, 12,500 feet is entered as 125. Entered data appears in the SD-3 window.

5. ENTER switch - Press.

NOTE

The DATA switch may now be used to display other than fixpoint data. If returned to FIXPOINT and ENTER before the fixpoint, anytime fixpoint data will be retained and displayed. The fix may be taken with the DATA switch in NORMAL. The viewsight opportunity fix must still be taken on the leg during which it was entered. Existing FPs will be inhibited until the Anytime FP is passed.

ADD OR REPLACE (NON ASARS) FP, CP, DP

NOTE

- For DPs perform steps 1 through 4, then 9 and 10.
- For CPs, perform steps 1 through 5, then 6, 7, 8 and 10.
- For FPs, perform steps 1 through 5, and 10.

In any "operate" mode:

1. DATA switch - DEST POINT, FIX POINT, or CONT PT.
2. Enter ID code (five digits) of FP, CP, or DP to be added or replaced. All entered digits appear in SD-6 window.

NOTE

- 0XXXX Point No. displays DXXXX, FXXXX, or CXXXX, 1XXXX Point No. displays F1XXXX or C1XXXX. Only zero allowed for first digit of DP.
- If a FP is added to be used immediately (Add-Anytime FP) do not enter an ID code number. All other FPs in memory will be inhibited until the added FP is passed.

3. Enter N or S and latitude of added or replaced point in degrees (two digits), minutes (two digits), and hundredths minutes (two digits). Entered data appears in SD-1 window.
4. Enter E or W and longitude of added or replaced point in degrees (three digits), minutes (two digits), and hundredths minutes (two digits). Entered data appears in SD-4 window.

Skip to step 8 if entered point is a DP; continue with step 5 if point is CP or FP.

5. Enter terrain elevation of FP or CP in hundreds of feet (three digits). Entered data appears in SD-3 window.

Skip to step 9 for viewsight FPs. Perform step 6 for camera CPs.

6. Press RIGHT or LEFT pushbutton and enter camera CP code (L/R plus 000). Entered data appears in SD-5 window.
7. For all CPs enter sensors on-off code (three digits). First entered digit is LH

SECTION IV

TECH camera, second is RH TECH camera. Enter 0 for off at CP, and 1 for on at CP. Corresponding sensor operation indicators illuminate to indicate sensor selection for the CP.

If a Fixed-Range-To-Turn is desired:

8. Enter turn radius of added or replaced DP in nm (three digits). Entered data appears in SD-3 window.
9. ENTER switch - Press.

REPLACE ASARS FP

In any "operate" mode:

1. DATA switch - FIX POINT.
2. Enter ID code (five digits) of FP to be replaced. ALL entered digits appear in SD-6 window.

NOTE

0XXXX Point No. displays FXXXX.

3. Enter N or S and latitude of added or replaced point in degrees (two digits), minutes (two digits), and hundredths minutes (two digits). Entered data appears in SD-1 window.
4. Enter E or W and longitude of added or replaced point in degrees (three digits), minutes (two digits), and hundredths minutes (two digits). Entered data appears in SD-4 window.

5. Enter terrain elevation of FP in hundreds of feet (three digits). Entered data appears in SD-3 window.
6. ENTER switch - Press.

ADD OR REPLACE ASARS CP

In any "operate" mode:

1. DATA switch - CONT PT.
2. Enter ID code (five digits) of CP to be added or replaced. All entered digits appear in SD-6 window.

NOTE

0XXXX Point No. displays CXXXX.

3. Enter N or S and latitude of added or replaced point in degrees (two digits), minutes (two digits), and hundredths minutes (two digits). Entered data appears in SD-1 window.
4. Enter E or W and longitude of added or replaced point in degrees (three digits), minutes (two digits), and hundredths minutes (two digits). Entered data appears in SD-4 window.
5. Enter terrain elevation of CP in hundreds of feet (three digits). Entered data appears in SD-3 window.
6. ASARS control point code -Enter (R0XXX). Entered data for first 4 digits appears in SD-5 window. Digit 5 indicated by illumination of sensor "L" light if value is 1.

ASARS Control Point CODE

Digit 1: L = Dual Spot (Not Available)
R = Normal

Digit 2: 0 = Neither Set
2 = Rewind
4 = Down link (Not Available)
6 = Both Set (Not Available)

NOTE: Selection of 4 or 6 will result in no ASARS imagery being recorded.

Digit 3: 0 = F1, Low Resolution (Spot only)
1 = F1, High Resolution (Spot only)
2 = F2, Low Resolution (Acquisition and Search only)
3 = F2, High Resolution (Not available)
4 = F3, Low Resolution (Spot only)
5 = F3, High Resolution (Not available)
6 = F4, Low Resolution (Acquisition and Search only)
7 = F4, High Resolution (Not available)

NOTE: Extreme care must be exercised in selecting resolution and frequency. Non available combinations of mode (Digit 4) and Resolution/Mode may be selected resulting in no ASARS activity.

Digit 4: 0 = Standby
1 = Acquisition
2 = Search
4 = Spot

Digit 5: 0 = Turn recorder off after this swath
1 = Leave recorder on after this swath

7. ENTER switch - Press.

NORMAL DISPLAY

In any "operate" mode:

1. DATA switch - NORMAL.
2. DISPLAY switch - Press.
 - a. SD-1 window displays letter Z and GMT in hours (two digits), minutes (two digits), and seconds (two digits).
 - b. SD-2 window displays letter T and true airspeed in knots (XXXX).
 - c. SD-3 window displays letter F or F1 and next FP (four digits).
 - d. SD-4 window displays R or L and cross track error in nautical miles (XXX.X).
 - e. SD-5 window displays letter G and ground speed in knots (XXXX).
 - f. SD-6 window displays letter C, C1, or A and next CP number (four digits). The ENTER/DISPLAY switch alternately selects ASARS or non-ASARS CP information.
 - g. Sensor indication lights illuminate when the associated sensor is programmed on.

DISPLAY SELECTED FP, CP, DP

In any "operate" mode:

1. DATA switch - DEST POINT, FIX POINT, or CONT PT.
2. Enter ID code (five digits) of desired FP, CP, or DP.

SD-6 window displays all entered digits (except first digit).

3. DISPLAY switch - Press.
 - a. SD-1 window displays latitude of selected point.
 - b. SD-2 window displays letter R and slant range to selected point if

SECTION IV

- TACAN, great circle range to CP or FP, or great circle range to DP.
- c. SD-3 window displays letter E and terrain elevation of selected FP or non-ASARS CP. For ASARS CP, letter M and ASARS mode information displayed. Sensor "L" light on or off also used in conjunction with ASARS mode. For DP, letter K and turn radius is displayed (255 nm max).
 - d. SD-4 window displays longitude of selected point.
 - e. SD-5 window displays L or R and relative bearing in degrees (four digits) to a selected CP or DP; or letter B and magnetic bearing in degrees (four digits), to TACAN FP.
 - f. SD-6 window displays data code of selected point.
 - g. L/R TECH and SLR lights illuminate to indicate sensor activity at selected FP or CP. The SLR light is not illuminated during display of viewsight fixpoints.
- c. SD-3 window displays letter E and terrain elevation of next FP or CP, in hundreds of feet. For DP, letter K and turn radius is displayed (255 NM max).
 - d. SD-4 window displays longitude of next FP, CP, or DP.
 - e. SD-5 window displays L or R and relative bearing in degrees (four digits) to next viewsight or radar FP, CP, DP, or letter B and magnetic bearing in degrees (four digits) to next TACAN FP.
 - f. SD-6 window displays data code of next FP, CP, or DP.
 - g. L/R TECH and SLR lights illuminate to indicate sensor activity at next FP or CP. The SLR light is not illuminated during display of viewsight fixpoints.

NOTE

- If there is no next FP or CP on the current leg, SD-2 window displays zero range and other displayed data will be for the preceding FP or CP. If there was no preceding FP or CP, all SELECTED DATA windows except 5 display all zeros. The SD-5 window displays bearing to zero latitude and longitude coordinates.
- If DATA switch is in DEST POINT and LOOK THRU switch is pressed:
 - 1) SD-1 window displays latitude of DP after next DP.
 - 2) SD-2 window displays range to DP after next DP.

DISPLAY NEXT NON-ASARS FP, CP, DP

MODE switch in ASTRO-INERTIAL, INERTIAL ONLY, DEAD RECKON, or AIR START position; MODE window displays any mode.

1. DATA switch - DEST POINT, FIX POINT, or CONT PT.
2. DISPLAY switch - Press.
 - a. SD-1 window displays latitude of next FP, CP, or DP.
 - b. SD-2 window displays letter R and slant range to TACAN FP, along track range for radar or viewsight FP or CP and along track range to turn start point (TSP) for DP (which includes the computed range around a closed loop turn).

- 3) SD-3 window displays turn radius of DP after next DP.
- 4) SD-4 window displays longitude of DP after next DP.
- 5) SD-5 window displays time to DP after next DP (four digits) in minutes and tenths.
- 6) SD-6 window displays the DP number after next DP. If no DP exists after next DP, SD-6 window displays D0000 and all other SELECTED DATA windows are blank.

DISPLAY DAY OF YEAR/STAR DATA

In any "operate" mode:

1. DATA switch - TIME.
2. DISPLAY switch - Press.
 - a. SD-1 window displays letter Z and GMT in hr., min, sec.
 - b. SD-2 window displays letter S and star number.
 - c. SD-3 window displays the scan rate code of the star-tracking telescope (R1, R2, R3 or R4).
 - d. SD-4 window displays letter T and time in star search in min. and sec.
 - e. SD-5 window displays letter A and number of stars acquired.
 - f. SD-6 window displays letter D and Julian date.

NOTE

Julian day Display changes after 2400 GMT and may read any value from 0 to 511. Day values greater than 365 allow next calendar year usage of the star catalog in the computer.

DISPLAY HEADING

In any "operate mode":

1. DATA switch - HEADING.
2. DISPLAY switch - Press.
 - a. SD-1 window displays letter V and ground track in degrees (three digits), minutes (two digits), and tenths of minutes (one digit).
 - b. SD-2 window displays letter G and computed grid heading in degrees and tenths of degrees (four digits).
 - c. SD-3 window displays letter C and the chart convergence factor (four digits) (1.000 max).
 - d. SD-4 window displays letter T and true heading in degrees (three digits), minutes (two digits), and tenths of minutes (one digit).

NOTE

Displayed true heading is ANS inertial data except that INS data is used in dead-reckon mode and in ground and cold airstart coarse alignments until a heading update is performed.

- e. SD-5 window displays E/W magnetic variation (four digits).
- f. SD-6 window displays letter M and magnetic heading (three digits).

DISPLAY PRESENT POSITION

MODE switch: ASTRO INERTIAL, INERTIAL ONLY, DEAD RECKON, or AIR START; MODE window displays any mode.

1. DATA switch - PRES POSITION.
2. DISPLAY switch - Press.

SECTION IV

- a. SD-1 window displays N or S latitude of alternate frame in degrees (two digits), minutes (two digits), and hundredths of minutes (two digits).
- b. SD-2 window is blank.
- c. SD-3 window displays letter A and ANS altitude (three digits) (flight level).
- d. SD-4 window displays E or W longitude of alternate frame in degrees (three digits), minutes (two digits), and hundredths of minutes (two digits).
- e. SD-5 window displays letter S and sun angle in degrees and tenths (three digits).
- f. SD-6 window is blank.
- E. TIME-TO-TURN window displays the time to turn in hours, minutes, and seconds (five digits). The TIME-TO-TURN window displays 0 until the aircraft moves.
- F. RANGE TO DP (NM) window displays the range to the next destination point, shown in the NEXT DP window (four digits). Until the present position has been filled, the RANGE TO DP (NM) window will be blank.
- G. NEXT DP window displays the next destination point identification number (four digits). The first (left) digit is blank if the DP is not an added point, or the actual ADD NUMBER (1 thru 7) if the DP is an added point. Until present position has been filled, the NEXT DP window will be blank.

PRESENT DISPLAY

- A. PRESENT LATITUDE window displays present N/S latitude in degrees and minutes (four digits).
- B. PRESENT LONGITUDE window displays present E/W longitude in degrees and minutes (five digits).

NOTE

Window displays are blank until completion of F/A, at which time primary coordinates are displayed depending on MODE switch position.

- C. WIND DIR window displays present wind direction in degrees (three digits). While on the ground with ANS operating but not calculating, and if wind direction is not filled, the WIND DIR counter displays 000.
- D. WIND VEL window displays present wind velocity in knots (three digits). While on the ground with ANS operating but not calculating, the WIND VEL counter displays 0.

DISPLAY TAPE NUMBERS

In any "operate" mode:

- 1. DATA switch - TEST.
- 2. DISPLAY switch - Press.
 - a. SD-1 window displays letter I and main program tape number, (six digits) representing tape number, mod number, and correction number.
 - b. SD-2 window displays * or A thru Z or a thru e and mission tape number (three digits).
 - c. SD-3 window displays letter G and general instrument constants tape number (three digits).
 - d. SD-4 window is blank.
 - e. SD-5 window displays letter S and star catalog type as follows:
 - SYY1 - Normal (worldwide)
 - SYY2 - Trainer
 - Where YY=last two digits of the year.

- f. SD-6 window displays letter T (test) and 0.

ANS MALFUNCTION PROCEDURES

The ANS provides warning indications of some malfunctions or conditions external to the ANS that could lead to an ANS malfunction. All malfunctions are not detected, so the crew should not depend entirely on warning indications.

Temperature Limit/Tolerance Indicator

The LIMIT portion of the indicator is unlighted when temperatures within the ANS are normal. The red LIMIT can illuminate either steady or flashing. A steady light indicates that the temperature of the astroinertial instrument housing or the cooling air at the computer inlet is above nominal limits. Steady illumination after initial turn-on is caused by system over-temperature. A flashing light indicates that ANS cooling airflow is less than 2.5 pounds per minute. To prevent damage, turn the ANS off when the temperature LIMIT indicator comes on.

When the LIMIT light illuminates, the RSO's annunciator panel ANS FAIL light, and the pilot's annunciator panel ANS REF caution light illuminate.

When the TEMP TOLR light is unlighted, the platform temperature is in the range for optimum system performance. The amber TOLR light illuminates either steady or flashing. Steady illumination signifies that platform temperature is below normal. A flashing light signifies that temperature is above normal.

Figure 4-18 lists ANS temperature warning indications, conditions and recommended actions.

TEMP LIMIT Light Illuminates

1. Check ECS system.

If L or R air system failed:

- a. Complete L or R Air System Out procedure.

If L or R air system off for landing:

- b. Check cockpit air off (forward).

If TEMP LIMIT light remains illuminated:

- ▲ 2. ATT REF switch - INS.
- T 3. DISPLAY MODE SEL switch - Other than ANS.
- ④ 4. BDHI HDG SELECT switch - INS.
- ⑤ 5. MODE switch - OFF.

CAUTION

If the TEMP LIMIT light cannot be extinguished, turn the MODE switch OFF to avoid damage to the ANS.

TEMP TOLR Light Illuminates in Flight

Make as many position checks as practical since navigation accuracy may degrade in a TEMP TOLR condition. Be alert for a possible TEMP LIMIT light.

SECTION IV

NOTE

If the TEMP TOLR light illuminates in flight, do not turn the ANS off unless the TEMP LIMIT light illuminates.

Malfunction Indicator (MAL Light)

The MODE window usually indicates action to be taken when the MAL light is flashing. Several of the conditions for a MAL light are synonymous with conditions for nav-not-ready indications described under the Warning Indication section. Figure 4-19 lists general ANS malfunction and nav-not-ready conditions.

NOTE

When the MAL light illuminates, the RSO's annunciator panel ANS FAIL light, and the pilot's annunciator panel ANS REF caution light illuminate.

Power Dropout

A decrease of the ANS ac supply voltage to less than 103 volts per phase causes the computer to stop operating regardless of mode. Voltage drop can be caused by a primary power transient, opening of the ANS 3-phase essential ac or essential dc circuit breaker(s), or turning the MODE switch to OFF or WARM UP. When power returns, the computer determines power dropout duration by comparing chronometer day and time with the day and time stored in memory at power loss.

If the power dropout is less than one second, operation resumes as though nothing occurred except star tracking is suspended for 70-seconds.

If the power dropout is greater than one second, the system returns to C/A, the MAL light illuminates, the MODE window indicates C/A, and all display counters clear. If the RSO presses the HOT switch, the system proceeds with an automatic restart (hot airstart or ground hot start). If, instead, the

RSO selects AIRSTART with the MODE switch and presses the MODE START switch, the system starts a COLD airstart. Refer to COLD Airstart Alignment, this section.

NOTE

- If the system is HOT started and then a COLD airstart is desired, return the MODE switch to OFF. If the MODE START switch is pressed in any MODE other than AIRSTART, the system must be turned off to initiate a COLD airstart.
- After a power dropout, pressing MODE START on the ground with the MAL light flashing (initiating a ground alignment) erases the 40-List. Anytime a rapid or a gyro-compass ground alignment is performed, 40-List data must be reentered. 40-List data is not deleted if HOT is pressed with the MAL light flashing or if a cold or hot airstart is performed. Therefore, 40-List data is retained for a ground hot start, cold airstart, or a hot airstart. Pressing the MODE START switch with a steady MAL light has no effect on the 40-List.
- Complete loss of ac or dc power to the guidance group will cause all ANS NCD panel lights and windows to extinguish/go blank.

Chronometer Failure

The system checks the chronometer day and time inputs when the MODE switch is turned to an "operate" mode and after a power dropout. If the chronometer inputs are not present, a chronometer failure has occurred. This is indicated by a flashing MAL light, clearing of the present position display, and I/O in the MODE window. The system will return to a coarse align condition. The MAL light will not clear without corrective action. On the ground, the alternatives are to

ANS TEMPERATURE WARNINGS

INDICATOR	STATE	ANS CONDITION	ACTION
Red TEMP LIMIT Light	Off	Within safe limits.	_____
	Steady	Air inlet housing or cooling air at computer inlet above design limits.	Turn MODE switch OFF.
	Flashing	Cooling air flow less than 2.5 lb/min.	Turn MODE switch OFF.
Amber TEMP TOLR Light	Off	Within tolerance for optimum accuracy.	_____
	Steady	Platform temp below normal.	Check ANS accuracy.
	Flashing	Platform temp above normal.	Be alert for TEMP LIMIT. Check ANS accuracy. Keep rpm up if warning on due to hot fuel in flight.

Figure 4-60

replace the chronometer, perform the fill Day and Time routine, or to select INERTIAL ONLY. A Hot Airstart may be possible after a chronometer failure if the Fill Day and Time procedure is used.

Incorrect chronometer day or time does not result in a chronometer malfunction, only incorrect inputs. With a chronometer failure, in the event of any power dropout (even less than one second), the MAL light will illuminate since the system cannot determine dropout duration.

NOTE

If the chronometer fails after the ANS is in ASTRO INERTIAL, the failure will not be apparent unless the ANS must be restarted. The ANS only interrogates the chronometer when it is initially activated.

Star Tracker Failure (During Ground Alignment)

Forty five seconds after initiation of C/A (for rapid and gyrocompassing ground alignments) the star tracker searches for the artificial star within the astroinertial instrument.

If the artificial star is tracked, the star light on the ANS NCD panel flashes until the system enters F/A. If the artificial star is not acquired and the alignment was initiated by pressing MODE START or RAPID, the MAL light flashes at the end of C/A and the MODE window indicates I/O. If the MAN CLEAR switch is pressed, the MAL light extinguishes and the MODE window will change to F/A. The alignment in progress proceeds normally. Since the most common cause of this malfunction indication is a

Pages 4-150 through 4-160
Advanced Synthetic Aperture Radar System (ASARS-1)

DELETED

IAW SR-71 Security Classification Guide
23 September 1996